

# COMBIVERT

# CE

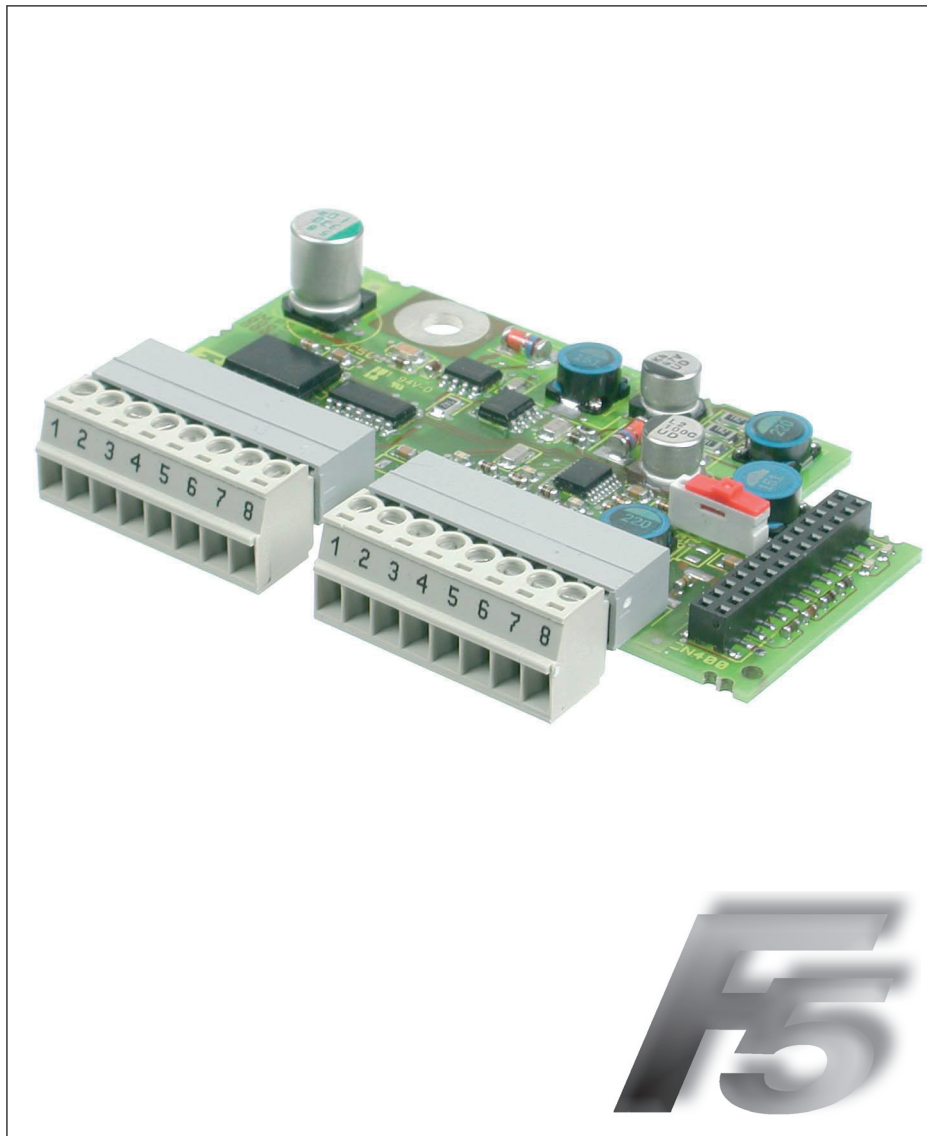

**GB**

INSTRUCTION MANUAL

Encoder Interface

Channel 1

HTL input without inverse signals

Channel 2

HTL Output





1. Safety Instructions .....	4
1.1 Validity .....	4
1.2 Qualification.....	4
2. Product Description.....	5
2.1 General.....	5
2.2 Material number .....	5
2.3 Mechanical installation .....	6
3. Description of the Interface .....	6
3.1 Power supply .....	6
3.1.1 Adjustment of the supply voltage .....	7
3.2 Channel 1 .....	7
3.2.1 Description of terminal strip X3A.....	8
3.2.2 Input signals channel 1.....	8
3.2.2.1 Signal tracks.....	8
3.2.2.2 Evaluation of the zero signal .....	9
3.2.2.3 Encoder breakage recognition .....	9
3.2.3 Connection of the encoder .....	10
3.2.4 Encoder cable .....	10
3.2.5 Encoder line length.....	10
3.2.6 Tested encoder .....	11
3.3 Channel 2 .....	11
3.3.1 Description of terminal strip X3B .....	11
3.3.2 Output signals channel 2.....	12
4. Start-up .....	12
5. Error Messages.....	12

## 1. Safety Instructions

Prior to performing any work on the unit the user must familiarize himself with the unit. This includes especially the knowledge and observance of the safety and warning directions. The pictographs used in this instruction manual have following meaning:

	Danger	Refers to danger of life by electric current.
---	--------	---

	Warning	Refers to possible danger of injury or life.
---	---------	--

	Note	Refers to tips and additional information.
---	------	--

### 1.1 Validity

The information contained in the technical documentation, as well as any user-specific advice in spoken and written and through tests, are made to best of our knowledge and information about the application. However, they are considered for information only without responsibility. This also applies to any violation of industrial property rights of a third-party.

Inspection of our units in view of their suitability for the intended use must be done generally by the user. Inspections are particularly necessary, if changes are executed, which serve for the further development or adaption of our products to the applications (hardware, software or download lists). Inspections must be repeated completely, even if only parts of hardware, software or download lists are modified.

	Controlling by the user	Application and use of our units in the target products is outside of our control and therefore lies exclusively in the area of responsibility of the user.
---	-------------------------	---

	Use under special conditions	The used semiconductors and components of KEB are developed and dimensioned for the use in industrial products. If the KEB COMBIVERT is used in machines, which work under exceptional conditions or if essential functions, life-supporting measures or an extraordinary safety step must be fulfilled, the necessary reliability and security must be ensured by the machine builder.
---	------------------------------	---

### 1.2 Qualification

All operations serving transport, installation and commissioning as well as maintenance are to be carried out by skilled technical personnel (observe IEC 364 or CENELEC HD 384 or DIN VDE 0100 and national accident prevention rules!). According to this manual qualified staff means:

- those who are able to recognise and judge the possible dangers based on their technical training and experience
- those with knowledge of the relevant standards and who are familiar with the field of power transmission (VDE 0100, VDE 0160 (EN 50178), VDE 0113 (EN 60204) as well as the appropriate regulations for your area.



**Danger by high voltage**

KEB electronics components contain dangerous voltages which can cause death or serious injury. In operation, drive converters, depending on their degree of protection, may have live, uninsulated, and possibly also moving and hot surfaces.

In case of inadmissible removal of the required covers, of improper use, wrong installation or maloperation, there is the danger of serious personal injury and damage to property.

## 2. Product Description

Figure 1: Encoder interface 1M.F5.280-8009

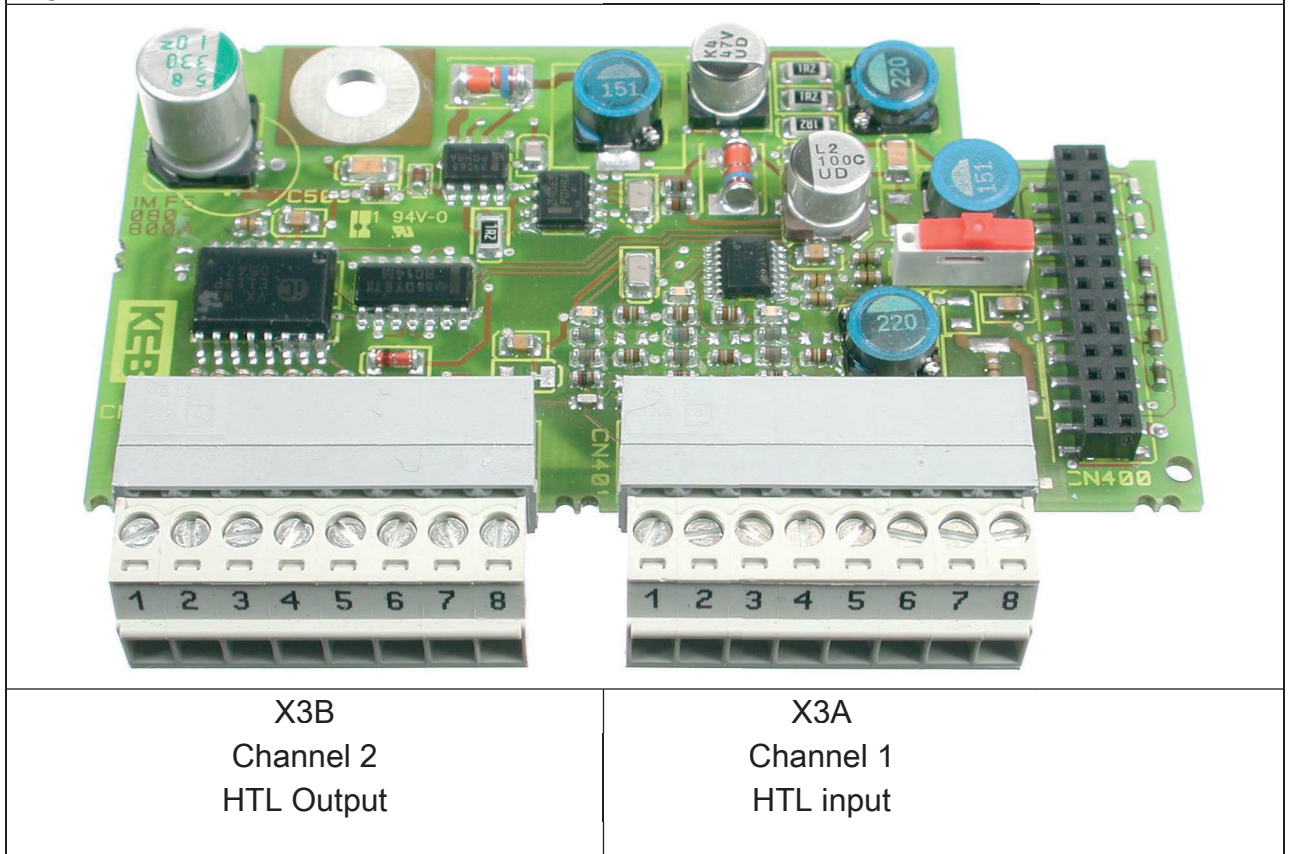

### 2.1 General

The available encoder interface includes an input for connection of incremental encoders with HTL level, as well as an output which simulates an incremental encoder with HTL level. The instruction covers the installation of the interface card, the connection as well as the start-up of a suitable encoder. Further information and the parameter adjustments are described in the application manual for the inverter/servo.

### 2.2 Material number

1M | F5 | K81 | 8 | 0 | 0 | 9

			0	installed		Z	Option, spare part		
			8	HTL input / HTL output					
			F5	Series					
			1M	Applicable for housing size D, E (PCB 1M.F5.280-8009)					

## 2.3 Mechanical installation

All kind of works on the inverter may be carried out by authorized personnel in accordance with the EMC and safety rules only.

- Switch inverter de-energized and await capacitor discharge time
- Pull off operator
- Remove plastic cover
- Remove fixing bolt
- Fix interface board beginning from the socket connector straightly
- Screw in fixing bolt
- Adjust desired supply voltage with DIL switch
- Attach plastic cover



## 3. Description of the Interface

### 3.1 Voltage supply

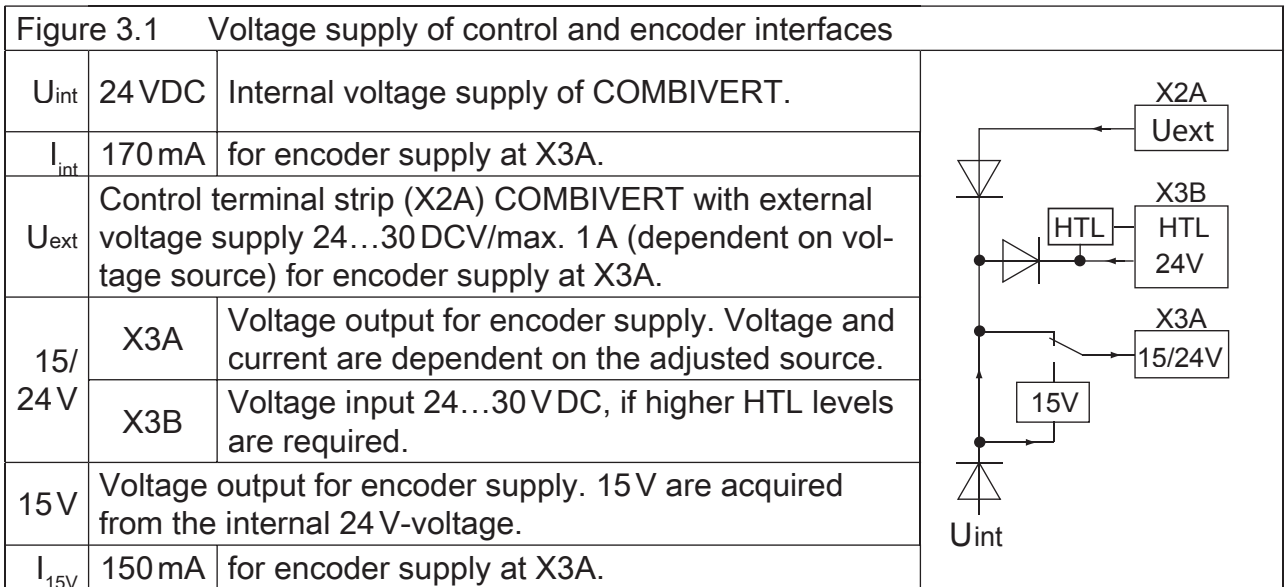
Supply voltage for interface and encoders is made available by the frequency inverter. The voltage to the encoder supply is switchable between 24 V (standard) and 15 V. An external supply must be used if higher signal voltages or currents than mentioned below are required. The voltage input at X3B is used only for the HTL signal levels.

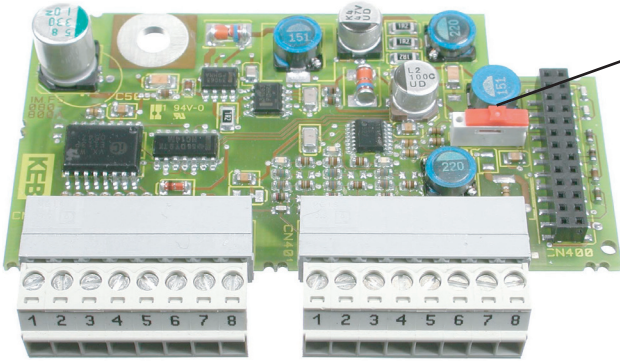

## 3.1.1 Adjustment of the Supply Voltage

Figure 2.1.1 Adjustment of the supply voltage for channel 1		
	DIL switch S400	
		
	24 V internal or external supply	15 V

## 3.2 Channel 1

Terminal strip	X3A
Interface type	Incremental Encoder Input
Input signals	HTL 15...30 V without inverse signals
Inputs / tracks	A+, B+, N+
Output	Voltage output for encoder supply
Particularities	Encoder breakage recognition for all signals
Limiting frequency	100 kHz
Increments per revolution	1...16383 inc (recommendation 2500 inc for speed upto 2400 rpm)
Input resistance	3,6 k $\Omega$ at 24 V input voltage

## 3.2.1 Description of terminal strip X3A

Figure 2.1.1 Terminal strip X3A

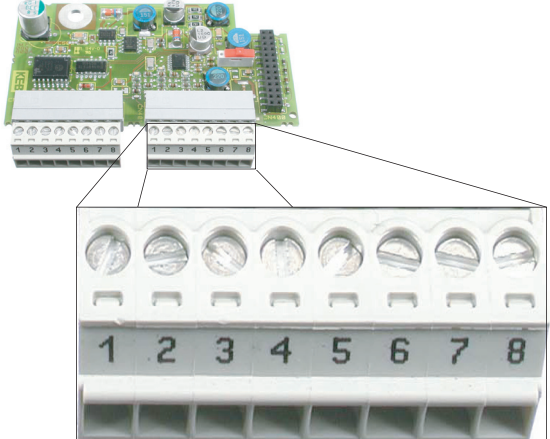
	Stripping length	mm	7
	Tightening torque	Nm	0,22
		lb inch	2
	Conductor cross-section (min)	mm <sup>2</sup>	0,14
		AWG	28
	Conductor cross-section (max)	mm <sup>2</sup>	1,5
AWG		16	

PIN	Name	Description
1	A+	Encoder track A
2	-	reserved
3	B+	Encoder track B
4	-	reserved
5	N+	Zero track
6	-	reserved
7	15/24 V	Voltage output for encoder supply
8	COM	Reference potential for encoder tracks and voltage supply

## 3.2.2 Input signals channel 1

### 3.2.2.1 Signal tracks

In case of HTL encoder interface the signals A+ and B+ are rectangular signals with a phase-angle displacement by 90 degrees. The inverted signals will be generated internally and does not need to be provided by the encoder. The pulse width and the phase difference must be 2 μs at least.

Figure 2.2.1 Signal tracks A+ and B+

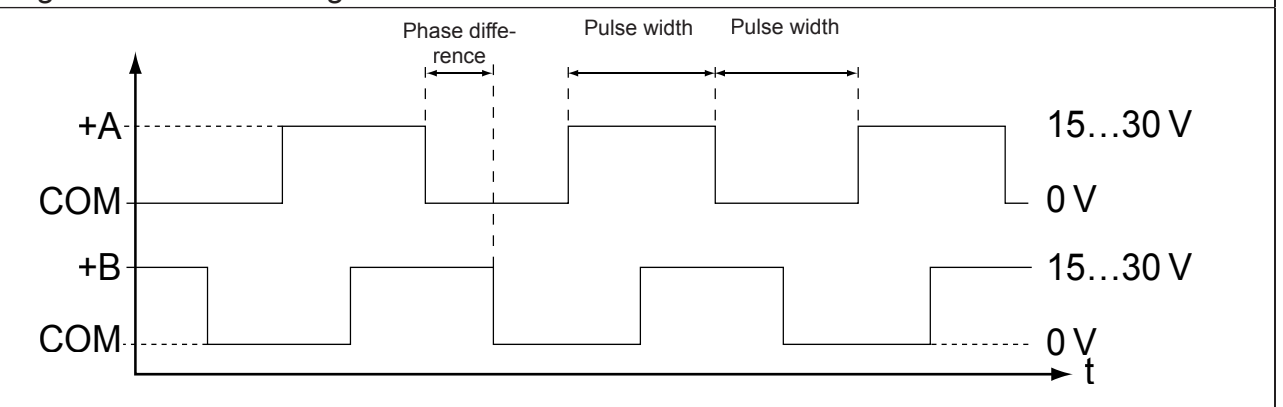



### 3.2.2.2 Evaluation of the zero signal

The zero impulse is required to determine valid position points. In case of pure speed controls the signal does not need to be connected. In the following signal sequence the maximum permissible length of the zero impulse of the encoder is visible. The zero signal will be acquired if A+ ,B+ and N+ are at high level. By that there is only one valid position point which is independent from the travel direction. Input N+ must be connected with input 15/24 V if the encoder does not support a zero track.

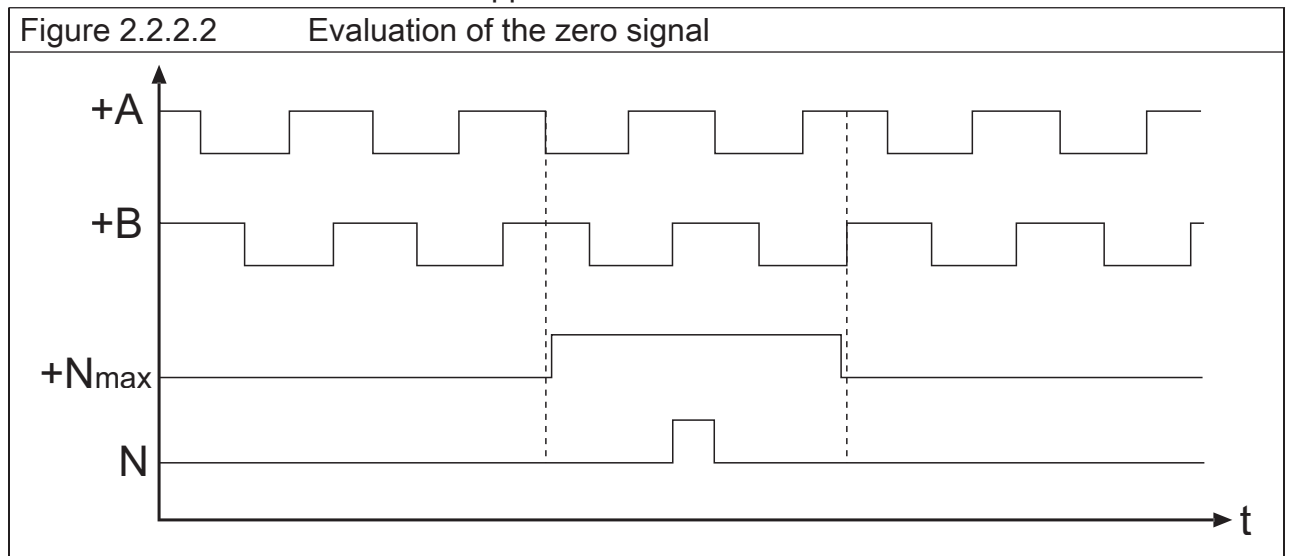

### 3.2.2.3 Encoder breakage recognition

For a monitoring of the encoder and the encoder cable the signal tracks and the zero track are monitored. Input N+ must be connected with input 15/24 V if the connected encoder should not have a zero track. The monitoring for channel 1 will be switched on/off with parameter Ec.42 (Ec.20 up to V2.8).

The recognition of encoder breakage triggers an „error! encoder 1“ (value 32), if the voltage at the signal input is smaller than 6 V.



### 3.2.6 Tested encoders

The following HTL-incremental encoder have been tested by KEB on it application:

- Heidenhain ROD436

However, this does not restrict the use of rotary encoder with same specifications of other manufacturers.

### 3.3 Channel 2

Terminal strip	X3B
Interface type	Incremental encoder simulation (output)
Output signals	HTL 20...26 V (input voltage - 4 V) max. 30 mA per output (briefly short-circuit proof)
Outputs / tracks	A+, A-, B+, B-, N+, N-
Input	Voltage output for HTL signal level
Increments per revolution	programmable
Max. line length	50 m, the value is additionally limited by the signal frequency, cable capacity and supply voltage.

#### 3.3.1 Description of terminal strip X3B

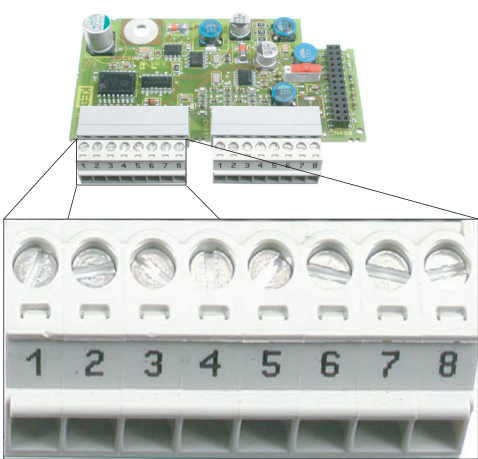
Figure 2.1.1 Terminal strip X3B			
	Stripping length	mm 7	
	Tightening torque	Nm	0,22
		lb inch	2
	Conductor cross-section (min)	mm <sup>2</sup>	0,14
		AWG	28
	Conductor cross-section (max)	mm <sup>2</sup>	1,5
AWG		16	
PIN	Name	Description	
1	A+	Encoder track A HTL signal+	
2	B+	Encoder track B HTL signal+	
3	N+	Zero track HTL signal+	
4	A-	Encoder track A HTL signal-	
5	B-	Encoder track B HTL signal-	
6	N-	Zero track HTL signal-	
7	24 V	Voltage input 24...30 V, if higher HTL level are required.	
8	COM	Reference potential for voltage supply. Reference potential for encoder tracks, if the signals are used as single-ended signals (without inverse signals).	

## 3.3.2 Output signals channel 2

At the HTL encoder simulation the signal tracks A and B are electrically phase-shifted by 90°. The output signals can be connected optionally as difference signal with the respective inverse tracks or as single-ended signals. The zero signal is output once per revolution with the same level.

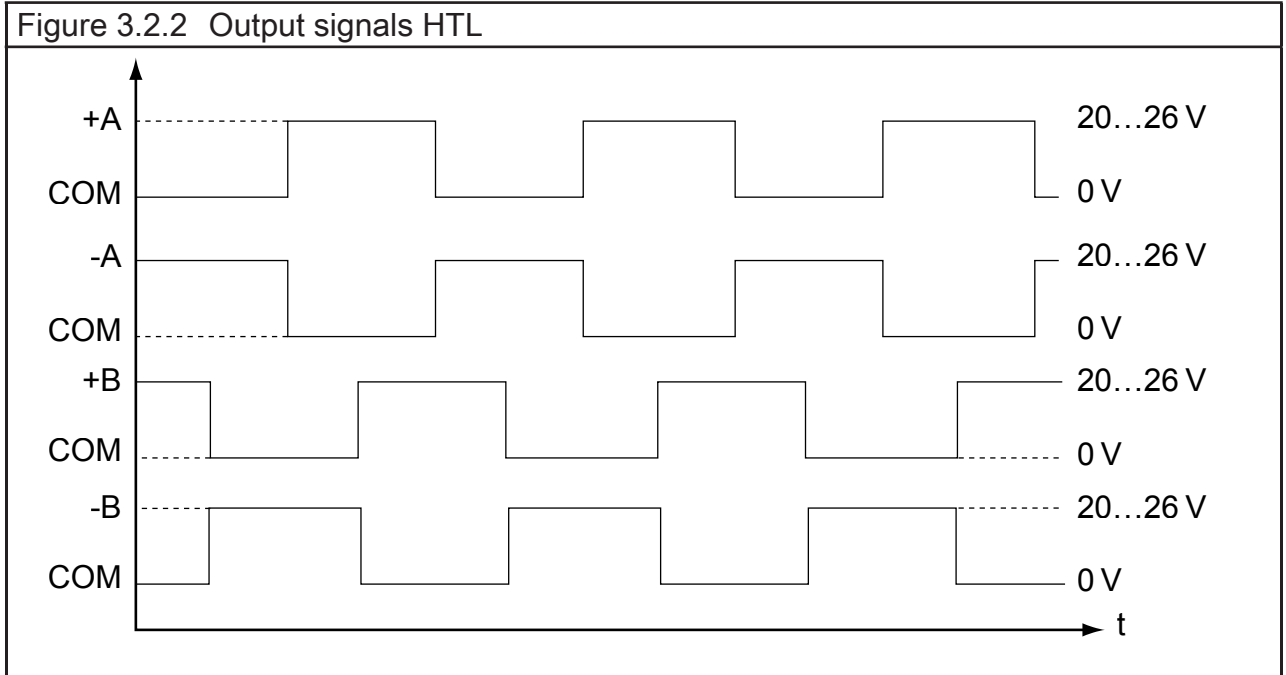

## 4. Start-up

After the installation or exchange of an encoder interface some adjustments of the inverter/ servo software have to be done before operation:

- Switch on inverter
- Select application mode
- Select parameter Ec.0 and control whether value „15: inc. input with alarm 24V HTL“ is entered. The displayed value has to be confirmed by „ENTER“ in any case.
- Select parameter Ec.10 and control whether value „24: inc.input simulation“ is entered.
- Select parameter Ec.1 and adjust increments per revolution
- Select Ec.42 (Ec.20 upto V2.8) and adjust the encoder breakage recognition dependent on the case of operation.

## 5. Error Messages

Error messages and their meaning are described in Chapter 9 of the application manual.





**KEB Automation KG**

Südstraße 38 • D-32683 Barntrup  
fon: +49 5263 401-0 • fax: +49 5263 401-116  
net: [www.keb.de](http://www.keb.de) • mail: [info@keb.de](mailto:info@keb.de)

**KEB Antriebstechnik GmbH & Co. KG**

Wildbacher Str. 5 • D-08289 Schneeberg  
fon: +49 3772 67-0 • fax: +49 3772 67-281  
mail: [info@keb-combidrive.de](mailto:info@keb-combidrive.de)

**KEB Antriebstechnik Austria GmbH**

Ritzstraße 8 • A-4614 Marchtrenk  
fon: +43 7243 53586-0 • fax: +43 7243 53586-21  
net: [www.keb.at](http://www.keb.at) • mail: [info@keb.at](mailto:info@keb.at)

**KEB Antriebstechnik**

Herenveld 2 • B-9500 Geraadsbergen  
fon: +32 5443 7860 • fax: +32 5443 7898  
mail: [vb.belgien@keb.de](mailto:vb.belgien@keb.de)

**KEB Power Transmission Technology (Shanghai) Co. Ltd – Office Room 401**

No. 665 North Songwei Road (New Husong Road),  
Songjiang District, CHN-201613 Shanghai, P.R. China  
fon: +86 21 51095995 • fax: +86 21 54450115  
net: [www.keb.cn](http://www.keb.cn) • mail: [info@keb.cn](mailto:info@keb.cn)

**KEB Antriebstechnik Austria GmbH**

Organizační složka  
K. Weise 1675/5 • CZ-370 04 České Budějovice  
fon: +420 387 699 111 • fax: +420 387 699 119  
net: [www.keb.cz](http://www.keb.cz) • mail: [info.keb@seznam.cz](mailto:info.keb@seznam.cz)

**KEB España**

C/ Mitjer, Nave 8 - Pol. Ind. LA MASIA  
E-08798 Sant Cugat Sesgarrigues (Barcelona)  
fon: +34 93 897 0268 • fax: +34 93 899 2035  
mail: [vb.espana@keb.de](mailto:vb.espana@keb.de)

**Société Française KEB**

Z.I. de la Croix St. Nicolas • 14, rue Gustave Eiffel  
F-94510 LA QUEUE EN BRIE  
fon: +33 1 49620101 • fax: +33 1 45767495  
net: [www.keb.fr](http://www.keb.fr) • mail: [info@keb.fr](mailto:info@keb.fr)

**KEB (UK) Ltd.**

6 Chieftain Buisness Park, Morris Close  
Park Farm, Wellingborough GB-Northants, NN8 6 XF  
fon: +44 1933 402220 • fax: +44 1933 400724  
net: [www.keb-uk.co.uk](http://www.keb-uk.co.uk) • mail: [info@keb-uk.co.uk](mailto:info@keb-uk.co.uk)

**KEB Italia S.r.l.**

Via Newton, 2 • I-20019 Settimo Milanese (Milano)  
fon: +39 02 33535311 • fax: +39 02 33500790  
net: [www.keb.it](http://www.keb.it) • mail: [kebitalia@keb.it](mailto:kebitalia@keb.it)

**KEB Japan Ltd.**

15-16, 2-Chome, Takanawa Minato-ku  
J-Tokyo 108-0074  
fon: +81 33 445-8515 • fax: +81 33 445-8215  
mail: [info@keb.jp](mailto:info@keb.jp)

**KEB Korea Seoul**

Room 1709, 415 Missy 2000  
725 Su Seo Dong, Gang Nam Gu  
ROK-135-757 Seoul/South Korea  
fon: +82 2 6253 6771 • fax: +82 2 6253 6770  
mail: [vb.korea@keb.de](mailto:vb.korea@keb.de)

**KEB RUS Ltd.**

Dolgorukovskaja str. 33, building 8  
RUS-127006 Moscow  
fon: +007 499 972 3162 • fax: +007 499 978 9573  
mail: [info@keb.ru](mailto:info@keb.ru)

**KEB Sverige**

Box 265 (Bergavägen 19)  
S-43093 Hälsö  
fon: +46 31 961520 • fax: +46 31 961124  
mail: [vb.schweden@keb.de](mailto:vb.schweden@keb.de)

**KEB America, Inc.**

5100 Valley Industrial Blvd. South  
USA-Shakopee, MN 55379  
fon: +1 952 224-1400 • fax: +1 952 224-1499  
net: [www.kebamerica.com](http://www.kebamerica.com) • mail: [info@kebamerica.com](mailto:info@kebamerica.com)