



# EtherCAT®



## COMBIVERT G6

INSTRUCTIONS FOR USE | INSTALLATION G6 CONTROL ETHERCAT

Translation of the original manual  
Document 20137576 EN 00



# Preface

The described hard- and software are developments of the KEB Automation KG. The enclosed documents correspond to conditions valid at printing. Misprint, mistakes and technical changes reserved.

## Signal words and symbols

Certain operations can cause hazards during the installation, operation or thereafter. There are safety informations in the documentation in front of these operations. Security signs are located on the device or machine. A warning contains signal words which are explained in the following table:

<b>DANGER</b>	Dangerous situation, which will cause death or serious injury in case of non-observance of this safety instruction.
<b>WARNING</b>	Dangerous situation, which may cause death or serious injury in case of non-observance of this safety instruction.
<b>CAUTION</b>	Dangerous situation, which may cause minor injury in case of non-observance of this safety instruction.
<b>Attention</b>	Situation, which can cause damage to property in case of non-observance.

### RESTRICTION

Is used when certain conditions must meet the validity of statements or the result is limited to a certain validity range.



Is used when the result will be better, more economic or trouble-free by following these procedures.

## More symbols

- ▶ This arrow starts an action step.
- / - Enumerations are marked with dots or indents.
- => Cross reference to another chapter or another page.



Note to further documentation.  
<https://www.keb.de/de/service/downloads.html>



## Laws and guidelines

KEB Automation KG confirms with the CE mark and the EC declaration of conformity, that our device complies with the essential safety requirements.

The CE mark is located on the name plate. The EC declaration of conformity can be downloaded on demand via our website. Further information is provided in chapter "Certification".

## Warranty

The warranty on design, material or workmanship for the acquired device is given in the current terms and conditions.



Here you will find our current terms and conditions.  
<https://www.keb.de/de/agb.html>



Further agreements or specifications require a written confirmation.

## Support

Through multiple applications not every imaginable case has been taken into account. If you require further information or if problems occur which are not treated detailed in the documentation, you can request the necessary information via the local KEB Automation KG agency.

**The use of our units in the target products is beyond of our control and therefore exclusively the responsibility of the machine manufacturer, system integrator or customer.**

The information contained in the technical documentation, as well as any user-specific advice in spoken and written and through tests, are made to best of our knowledge and information about the application. However, they are considered for information only without responsibility. This also applies to any violation of industrial property rights of a third-party.

Selection of our units in view of their suitability for the intended use must be done generally by the user.

**Tests can only be done within the application by the machine manufacturer. They must be repeated, even if only parts of hardware, software or the unit adjustment are modified.**

## Copyright

The customer may use the instruction manual as well as further documents or parts from it for internal purposes. Copyrights are with KEB Automation KG and remain valid in its entirety.

Other wordmarks or/and logos are trademarks (™) or registered trademarks (®) of their respective owners and are listed in the footnote on the first occurrence.

# Table of Contents

<b>Preface</b> .....	<b>3</b>
Signal words and symbols .....	3
More symbols.....	3
Laws and guidelines.....	4
Warranty .....	4
Support .....	4
Copyright.....	4
<b>Table of Contents</b> .....	<b>5</b>
<b>List of Figures</b> .....	<b>6</b>
<b>List of Tables</b> .....	<b>6</b>
<b>Glossary</b> .....	<b>7</b>
<b>Used standards</b> .....	<b>9</b>
<b>1 Basic Safety Instructions</b> .....	<b>11</b>
1.1 Target group.....	11
1.2 Validity of this manual.....	11
1.3 Electrical connection .....	12
1.4 Start-up and operation .....	12
<b>2 Product Description</b> .....	<b>13</b>
2.1 Part code .....	13
<b>3 Control EtherCAT</b> .....	<b>15</b>
3.1 Overview.....	15
3.2 Status LEDs .....	16
3.2.1 Inverter status LED1.....	16
3.2.2 EtherCAT status LED2 .....	16
3.3 Connections.....	17
3.3.1 EtherCAT IN and EtherCAT OUT .....	17
3.3.2 Diagnosis/visualisation .....	17
3.3.2.1 Assignment of the interface X4A .....	18
3.3.2.2 Connection of the RS232 interface .....	18
3.3.2.3 Connection of the RS485 interface .....	18
3.3.2.4 Wiring RS485 full duplex .....	19
3.3.2.5 Wiring RS485 half duplex.....	19
3.3.3 Control terminal strip X2A.....	20
3.3.3.1 Assembly of the wires.....	20
3.3.3.2 Assignment of the terminal strip X2A.....	21
3.3.3.3 Connection of the digital inputs .....	23
3.3.3.4 Connection of the digital outputs.....	24
3.3.3.5 Connection of the relay outputs.....	24

<b>4</b>	<b>Parameter Description .....</b>	<b>25</b>
<b>5</b>	<b>Profile Parameters .....</b>	<b>26</b>
5.1	Profile parameters according to DSP301 .....	26
5.2	Profile parameters according to DSP402 .....	27

## List of Figures

Figure 1:	Overview .....	15
Figure 2:	EtherCAT IN and EtherCAT OUT .....	17
Figure 3:	Assignment of the interface X4A .....	18
Figure 4:	Connection of the RS232 interface .....	18
Figure 5:	Wiring RS485 full duplex .....	19
Figure 6:	Wiring RS485 half duplex .....	19
Figure 7:	Assembly of the wires .....	20
Figure 8:	Connection of the digital inputs .....	23
Figure 9:	Examples for the connection of the digital outputs .....	24
Figure 10:	Example for the connection of the relay outputs .....	24

## List of Tables

Table 1:	Part code .....	14
Table 2:	Inverter status LED1 .....	16
Table 3:	EtherCAT status LED2 .....	16
Table 4:	Diagnosis/visualisation .....	17
Table 5:	Assembly of the wires .....	20
Table 6:	Assignment of the terminal strip X2A .....	21
Table 7:	Factory setting of the digital inputs .....	23
Table 8:	Factory setting of the digital outputs .....	24
Table 9:	Factory setting of the relay outputs .....	24
Table 10:	Parameter description .....	25
Table 11:	Profile parameters according to DSP301 .....	26
Table 12:	Profile parameters according to DSP402 .....	27

## Glossary

0V	Earth-potential-free common point	KTY	Silicium temperature sensor (polarized)
1ph	1-phase mains	MCM	American unit for large wire cross sections
3ph	3-phase mains	Modulation	Means in drive technology that the power modules are controlled
AC	AC current or voltage	MTTF	Mean service life to failure
ASCL	Asynchronous sensorless closed loop	NN	Sea level
AWG	American wire gauge	OC	Overcurrent
BiSS	Open source real-time interface for sensors and actuators (DIN 5008)	OSSD	Output switching element; - an output signal that is checked in regular intervals on its shutdown. (safety technology)
CAN	Fieldbus system	PE	Protective earth
COMBIVERT	KEB drive converters	PELV	Protective Extra Low Voltage
COMBIVIS	KEB start-up and parameterizing software	PFD	Term used in the safety technology (EN 61508-1...7) for the size of error probability
DC	DC current or voltage	PFH	Term used in the safety technology (EN 61508-1...7) for the size of error probability per hour
DIN	German Institut for standardization	PLC	Programmable logic controller
EMC	Electromagnetic compatibility	Port	Part of a network address to the assignment of TCP and UDP connections
Emergency stop	Shutdown of a drive in emergency case (not de-energized)	PT100	Temperature sensor with R0=100Ω
Emergency switching off	Switching off the voltage supply in emergency case	PT1000	Temperature sensor with R0=1000Ω
Emulation	Software-generated encoder output	PTC	PTC-resistor for temperature detection
EN	European standard	PWM	Pulse width modulation
Endat	Bidirectional encoder interface of the company Heidenhain	RJ45	Modular connector with 8 lines
EtherCAT	Real-time Ethernet bus system of the company Beckhoff	SCL	Synchronous sensorless closed loop
FE	Functional earth	SELV	Electrically isolated low voltage (<60V)
FU	Drive converter	SIL	The security integrity level is a measure for quantifying the risk reduction. Term used in the safety technology (EN 61508 -1..7).
GND	Reference potential, ground	SS1	Safety function „Safe stop 1“ in accordance with IEC 61800-5-2
GTR7	Braking transistor	SSI	Synchronous serial interface for encoder
HF filter	High frequency filter to the mains		
Hiperface	Bidirectional encoder interface of the company Sick-Stegmann		
HMI	Human machine interface (touch screen)		
HSP5	Fast, serial protocol		
HTL	Incremental signal with an output voltage (up to 30V) -> TTL		
I <sup>2</sup> t-monitoring	Software function for thermal monitoring of the motor winding		
IEC	International standard		
IP xx	Degree of protection (xx for level)		

## GLOSSARY

STO	Safety function „Safe Torque Off“ in accordance with IEC 61800-5-2
TTL	Incremental signal with an output voltage up to 5 V
USB	Universal serial bus
VARAN	Real-time Ethernet bus system



## Used standards

DGUV regulation 3	Electrical systems and equipment
DIN 46228-1	Wire-end ferrules; Tube without plastic sleeve
DIN 46228-4	Wire-end ferrules; Tube with plastic sleeve
DIN IEC 60364-5-54	Low-voltage electrical installations - Part 5-54: Selection and erection of electrical equipment - Earthing arrangements, protective conductors and protective bonding conductors
EN 55011	Industrial, scientific and medical equipment - Radio frequency disturbance characteristics - Limits and methods of measurement
EN 55021	Interference to mobile radiocommunications in the presence of impulse noise - Methods of judging degradation and measures to improve performance
EN 60204-1	Safety of machinery - electrical equipment of machines Part 1: General requirements (VDE 0113-1, IEC 44/709/CDV)
EN 60439-1	Low-voltage switchgear and controlgear assemblies - Part 1: Type-tested and partially type-tested assemblies
EN 60529	Degrees of protection provided by enclosures (IP Code) (IEC 60529)
EN 60664-1	Insulation coordination for equipment within low-voltage systems Part 1: Principles, requirements and tests (IEC 60664-1)
EN 60721-3-1	Classification of environmental conditions - Part 3-1: Classification of groups of environmental parameters and their severities - section 1: Storage
EN 60721-3-2	Classification of environmental conditions - Part 3: Classification of groups of environmental parameters and their severities; section 2: Transport
EN 60721-3-3	Classification of environmental conditions - Part 3: Classification of groups of environmental parameters and their severities; section 3: Stationary use at weatherprotected locations
EN 61000-2-1	Electromagnetic compatibility (EMC) - Part 2: Environment - Section 1: Description of the environment - Electromagnetic environment for low-frequency conducted disturbances and signalling in public power supply systems
EN 61000-2-4	Electromagnetic compatibility (EMC) - part 2-4: Environment; Compatibility levels in industrial plants for low-frequency conducted disturbances
EN 61000-4-2	Electromagnetic compatibility (EMC) - part 4-2: Testing and measurement techniques - Electrostatic discharge immunity test
EN 61000-4-3	Electromagnetic compatibility (EMC) - part 4-3: Testing and measurement techniques - Radiated, radio-frequency, electromagnetic field immunity test
EN 61000-4-4	Electromagnetic compatibility (EMC) - part 4-4: Testing and measurement techniques - Electrical fast transient/burst immunity test
EN 61000-4-5	Electromagnetic compatibility (EMC) - part 4-5: Testing and measurement techniques - Surge immunity test
EN 61000-4-6	Electromagnetic compatibility (EMC) - part 4-6: Testing and measurement techniques - Immunity to conducted disturbances, induced by radio-frequency fields
EN 61000-4-34	Electromagnetic compatibility (EMC) - part 4-34: Testing and measurement techniques - Voltage dips, short interruptions and voltage variations immunity tests for equipment with mains current more than 16 A per phase
EN 61373	Railway applications - Rolling stock equipment - Shock and vibration tests
EN 61508-1...7	Functional safety of electrical/electronic/programmable electronic safety-related systems – Part 1...7 (VDE 0803-1...7, IEC 61508-1...7)
EN 61800-2	Adjustable speed electrical power drive systems - Part 2: General requirements - Rating specifications for low voltage adjustable frequency a.c. power drive systems (VDE 0160-102, IEC 61800-2)

## USED STANDARDS

EN61800-3	Speed-adjustable electrical drives. Part 3: EMC requirements and specific test methods (VDE 0160-103, IEC 61800-3)
EN61800-5-1	Electrical power drive systems with adjustable speed. Part 5-1: Requirements on the safety - electrical, thermal and energy requirements (VDE 0160-105-1)
EN61800-5-2	Electrical power drive systems with adjustable speed. Part 5-2: Requirements on the safety – functional safety (VDE 0160-105-2, UL61800-5-2)
EN62061	Safety of machinery - functional safety of electrical, electronic and programmable electronic safety-related systems (VDE 0113-50, IEC 62061)
EN ISO 13849-1	Safety of machinery - safety-related parts of control systems - Part 1: General principles for design (ISO 13849-1)
UL61800-5-1	American version of the EN61800-5-1 with „National Deviations“

# 1 Basic Safety Instructions

The COMBIVERT is designed and constructed in accordance with state-of-the-art technology and the recognised safety rules and regulations. However, the use of such devices may cause functional hazards for life and limb of the user or third parties, or damages to the system and other material property.

The following safety instructions have been created by the manufacturer for the area of electric drive technology. They can be supplemented by local, country- or application-specific safety instructions. This list is not exhaustive. Non-observance will lead to the loss of any liability claims.

## Attention

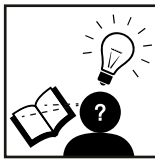

### Hazards and risks through ignorance.

- ▶ Read the instruction manual!
- ▶ Observe the safety and warning instructions!
- ▶ If anything is unclear, please contact KEB Automation KG!

## 1.1 Target group

This instruction manual is determined exclusively for electrical personnel. Electrical personnel for the purpose of this instruction manual must have the following qualifications:

- Knowledge and understanding of the safety instructions.
- Skills for installation and assembly.
- Start-up and operation of the product.
- Understanding of the function in the used machine.
- Detection of hazards and risks of the electrical drive technology.
- Knowledge of *DIN IEC 60364-5-54*.
- Knowledge of national safety regulations (e.g. *DGUV regulation 3*).

## 1.2 Validity of this manual

This manual describes the control part of the COMBIVERT G6 EtherCAT. The manual

- contains only supplementary safety instructions.
- is only valid in connection with the power unit manual of COMBIVERT G6.

### 1.3 Electrical connection

#### **⚠ DANGER**



#### **Voltage at the terminals and in the device !**

##### **Danger to life due to electric shock !**

- ▶ For any work on the unit switch off the supply voltage and secure it against switching on.
- ▶ Wait until the drive has stopped in order that no regenerative energy can be generated.
- ▶ Await capacitor discharge time (5 minutes) if necessary, measure DC voltage at the terminals.
- ▶ Never bridge upstream protective devices (also not for test purposes).

For a trouble-free and safe operation, please pay attention to the following instructions:

- The electrical installation shall be carried out in accordance with the relevant requirements.
- Cable cross-sections and fuses must be dimensioned according to the design of the machine manufacturer. Specified minimum / maximum values may not be fallen below /exceeded.
- With existing or newly wired circuits the person installing the units or machines must ensure the EN requirements are met.
- For drive converters that are not isolated from the supply circuit (in accordance with [EN 61800-5-1](#)) all control lines must be included in other protective measures (e.g. double insulation or shielded, earthed and insulated).
- When using components without isolated inputs/outputs, it is necessary that equipotential bonding exists between the components to be connected (e.g. by the equipotential line). Disregard can cause destruction of the components by equalizing currents.

### 1.4 Start-up and operation

The drive converter must not be started until it is determined that the installation complies with the machine directive; Account is to be taken of [EN 60204-1](#).

#### **⚠ WARNING**

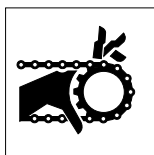

#### **Software protection and programming !**

##### **Hazards caused by unintentional behavior of the drive!**

- ▶ Check especially during initial start-up or replacement of the drive converter if parameterization is compatible to application.
- ▶ Securing a unit solely with software-supported functions is not sufficient. It is imperative to install external protective measures (e.g. limit switch) that are independent of the drive converter.
- ▶ Secure motors against automatic restart.

## 2 Product Description

The product family COMBIVERT G6 has been developed for the universal use at three-phase drives. The COMBIVERT G6 can be operated open-loop or encoderless speed or torque-controlled. The units are equipped with an integrated EMC filter.

### Attention

This accompanying instruction manual contains only information for the installation and connection of the EtherCat control of the KEB COMBIVERT G6.

Further parts of the installation manual are required depending on the ordered type:

- Connection and adjustments of the power unit.
- Safety function STO.

For manuals with general safety requirements and EMC conform installation please visit [www.keb.de](http://www.keb.de).

### 2.1 Part code

xx G6 xxx-xxx

Heat sink version <sup>1</sup>	0: Air-cooling (housing C, E); Air-cooling / flat rear (housing A, B)
	1: Flat rear
Control, Keyboard, Display <sup>1</sup>	A: G6L-G controlled without keyboard/display
	B: G6L-G controlled without keyboard/display
	2: G6P-S SCL <sup>2</sup> regulated without keyboard/display
	3: G6P-S SCL <sup>2</sup> regulated with keyboard/display
	4: G6L-M ASCL <sup>3</sup> regulated without keyboard/display
Switching frequency; Short time current limit; Overcurrent cut-off <sup>1</sup>	1: 4 kHz / 125% / 150%
	2: 8 kHz / 125% / 150%
	5: 4 kHz / 150% / 180%
	6: 8 kHz / 150% / 180%
	9: 4 kHz / 180% / 216%
A: 8 kHz / 180% / 216%	
Voltage / Connection type <sup>1</sup>	0: 1ph 230 V AC/DC
	1: 3ph 230 V AC/DC
	2: 1/3ph 230 V AC/DC
	3: 3ph 400 V AC/DC
	5: 3ph 400 V DC
	6: 1ph 230 V AC
	A-Z: Customer-/special version (firmware, hardware, download)
Housing	A, B, C, E

continued on the next page

**PRODUCT DESCRIPTION**

<b>x x</b>	<b>G6</b>	<b>x</b>	<b>x</b>	<b>x-x</b>	<b>x</b>	<b>x</b>	<b>x</b>
		Equipment		0: Without filter, without braking transistor, without safety function STO			
				1: Without filter, with braking transistor, without safety function STO			
				2: Internal filter; without braking transistor, without safety function STO			
				3: Internal filter, with braking transistor, without safety function STO			
				A: Like 0 with STO	H: Like A with f=0 Hz		
				B: Like 1 with STO	I: Like B with f=0 Hz		
				C: Like 2 with STO	K: Like C with f=0 Hz		
				D: Like 3 with STO	L: Like D with f=0 Hz		
		Control type		C: Analog/digital (standard)			
				D: CAN <sup>® 4</sup>			
				E: IO-Link <sup>® 5</sup>			
				F: EtherCAT <sup>® 6</sup>			
				H: Reserved			
		I: VARAN					
		Series		COMBIVERT G6			
		Inverter size		07...19			

**Table 1: Part code**

<sup>1</sup> Not valid for customer / special versions

<sup>2</sup> SCL = Sensorless Closed Loop

<sup>3</sup> ASCL = Asynchronous Sensorless Closed Loop

<sup>4</sup> CANopen<sup>®</sup> is registered trademark of CAN in AUTOMATION - International Users and Manufacturers Group e.V.

<sup>5</sup> IO-LINK<sup>®</sup> is registered trademark of PROFIBUS user organisation e.V.

<sup>6</sup> EtherCAT<sup>®</sup> is registered trademark and patented technology, licensed by Beckhoff Automation GmbH, Germany

### 3 Control EtherCAT

The control provides the following functions:

- EtherCAT slave interface.
- Hardware allocation of digital inputs and outputs.
- Diagnostic interface (parameter display, scope mode, data exchange).
- Hardware of the control circuit „safely separated“ according to EN 61800-5-1 (base TN-C/-S mains).
- LEDs for EtherCAT status and inverter status.
- With safety function STO (separate manual).
- Optional f=0 Hz functionality (separate manual).

#### 3.1 Overview

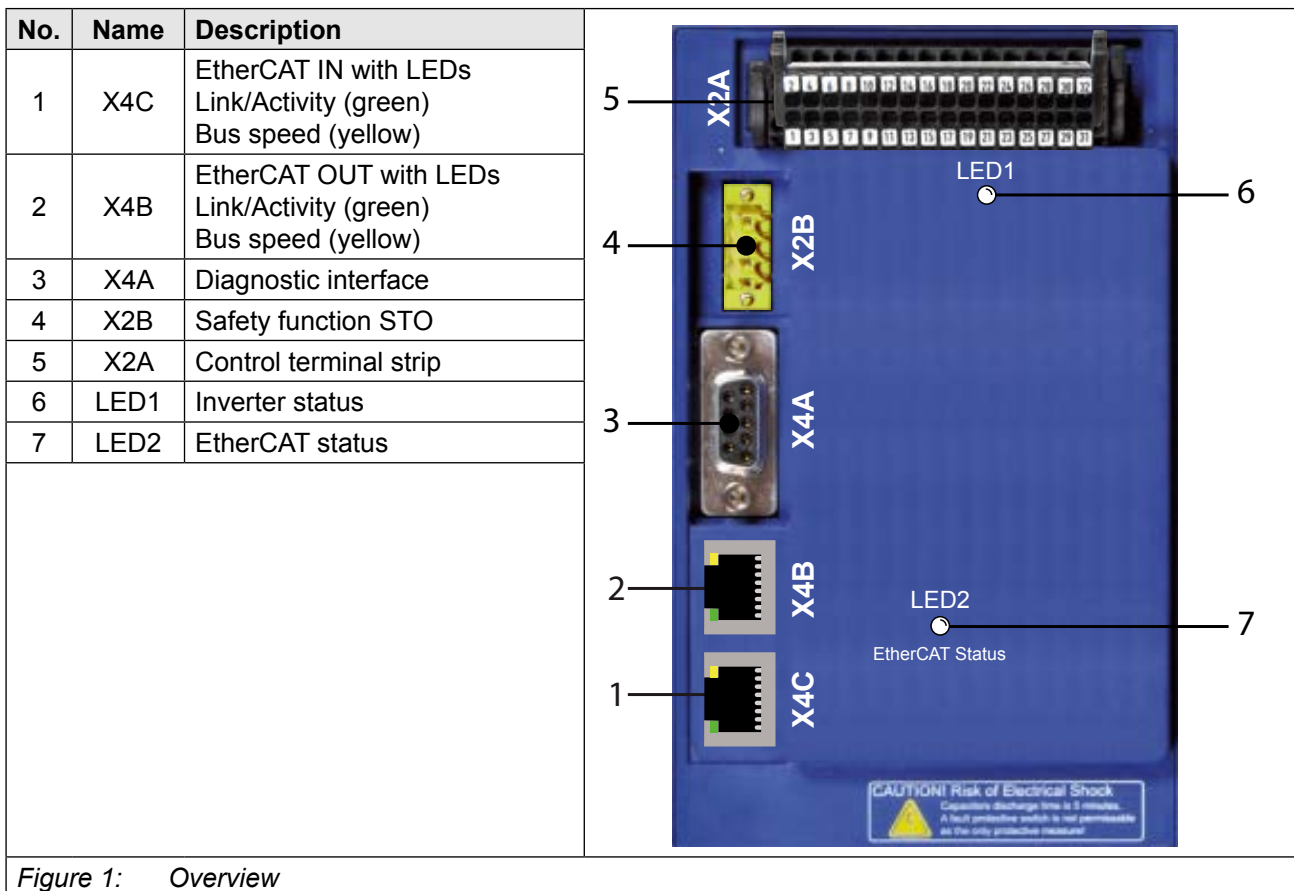

Figure 1: Overview

## 3.2 Status LEDs

### 3.2.1 Inverter status LED1

Pattern	Function
Off	Unit switched off
On	Unit ready for operation
Flashing	Unit in malfunction
<i>Table 2: Inverter status LED1</i>	

### 3.2.2 EtherCAT status LED2

The LED2 EtherCAT STATUS is a two-coloured combination of RUN LED (green) and ERROR LED (red). The RUN LED displays the status of the EtherCAT state machine (ESM). The ERROR LED displays watchdog errors and unwanted status changes in the case of local errors.

LED RUN (green)	Function
Off	Initialisation
Flashing	Ready for operation
Flickering	Boot
Easy Flash	Safe operation
On	Normal operation

LED ERROR (red)	Function
Off	No Error
Flashing	Configuration error (e.g. missing xml file)

LED general	Display
On	Continuous flashing
Flashing	200 ms on, 200 ms off, 200 ms on ...
Easy Flash	200 ms on, 1000 ms off, recurring
Double Flash	200 ms on, 200 ms off, 200 ms on, 1000 ms off, recurring
Flickering	50 ms on, 50 ms off, 50 ms on ...
Off	Dark
<i>Table 3: EtherCAT status LED2</i>	



### 3.3 Connections

#### 3.3.1 EtherCAT IN and EtherCAT OUT

Description of the LEDs		Name	Description
Bus speed (yellow)		X4B	EtherCAT OUT
Link/Activity (green)			
Bus speed (yellow)		X4C	EtherCAT IN
Link/Activity (green)			

Figure 2: EtherCAT IN and EtherCAT OUT

LED bus speed (yellow)	Function
Off	Transmission error
On	EtherCAT ready for operation with 100 MBit

LED Link/Activity (green)	Function
Off	Port closed; no data transfer
On	Port opened; no data transfer
Flicker	Port opened; with data transfer

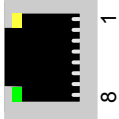
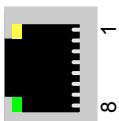

Xml files can be created with the free COMBIVIS 6 parameterization tool. For integration into other controls, further information are available on our homepage in the FAQ section.

#### 3.3.2 Diagnosis/visualisation

The integrated RS232/485 interface serves for the connection of service tools (e.g. COMBIVIS) and displays. Telegram DIN66019II is used as communication protocol. Die RS232/485-Schnittstelle liegt auf dem gleichen Potential wie die Steuerkarte.



The correct configuration and language file must be loaded for the operation with COMBIVIS. The download can be done via the KEB homepage or by COMBIVIS by online update.

Interface	Standard	Connecting cable
RS485	TIA/EIA-485 and ISO 8482	
RS232	ANSI TIA/EIA-232	0058025-001D
RS232/USB		0058060-0020

Table 4: Diagnosis/visualisation

3.3.2.1 Assignment of the interface X4A

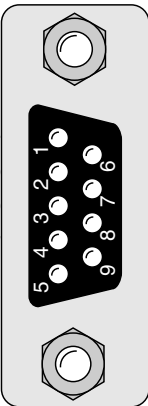
				
Reserved	1		6	Reserved
TxD (RS232)	2		7	DGND (reference potential)
RxD (RS232)	3		8	TxD-A (RS485)
RxD-A (RS485)	4		9	TxD-B (RS485)
RxD-B (RS485)	5			
<p>Figure 3: Assignment of the interface X4A</p>				

3.3.2.2 Connection of the RS232 interface

A RS232 cable is required to connect the control board with a PC. Transmission rate of 1.2...100kBaud is possible.

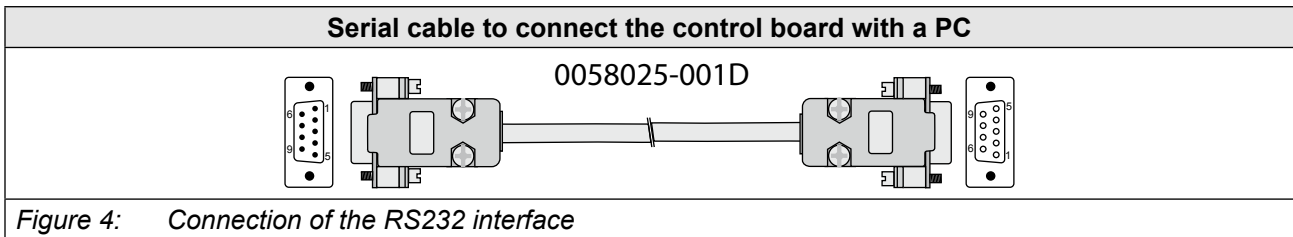

3.3.2.3 Connection of the RS485 interface

**Attention**

The following instructions must be observed in order to prevent interferences at the RS485 interface:

- Use in pairs, twisted and shielded cable.
- Ground outer shield at one side (prior at interference-free side).
- Connect terminating resistors (120Ω) at both ends on pair of wires of the communication bus.
- If available, the internal shielding must be laid at the transmitter to ground.
- Lay earth cable between the bus nodes.



A biasing can be used if there are still interferences. However, this should be done only once at the communication bus (preferably at the master).

3.3.2.4 Wiring RS485 full duplex

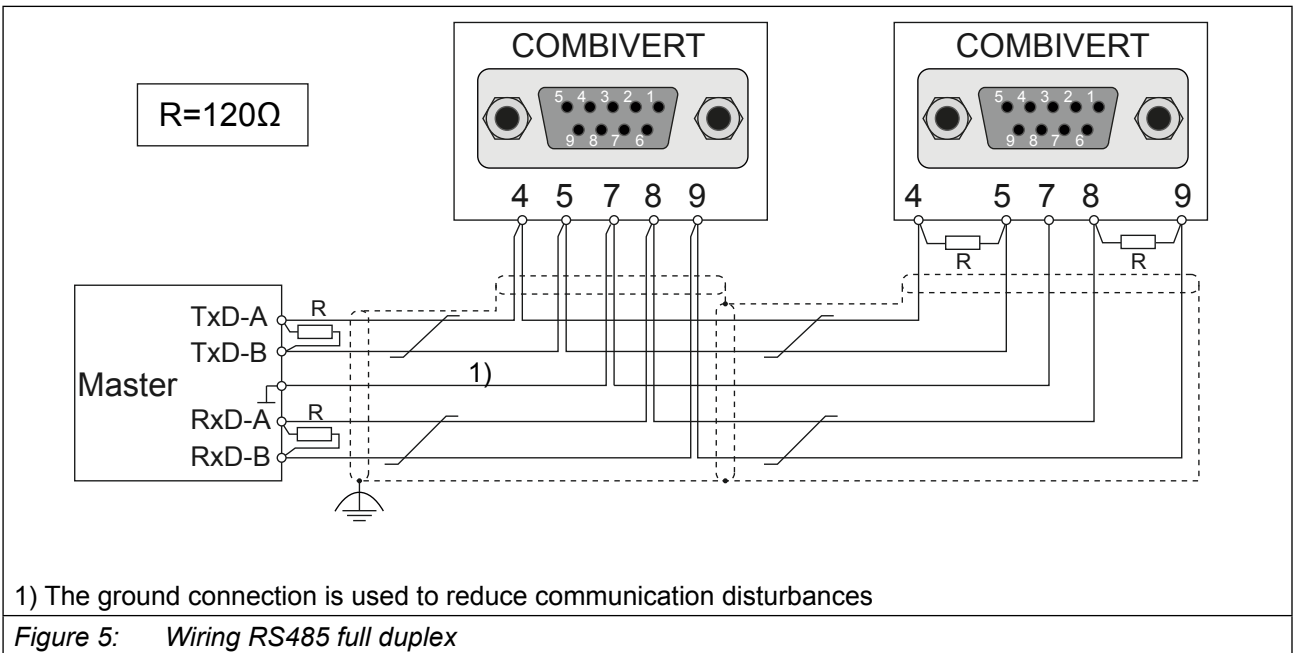

3.3.2.5 Wiring RS485 half duplex

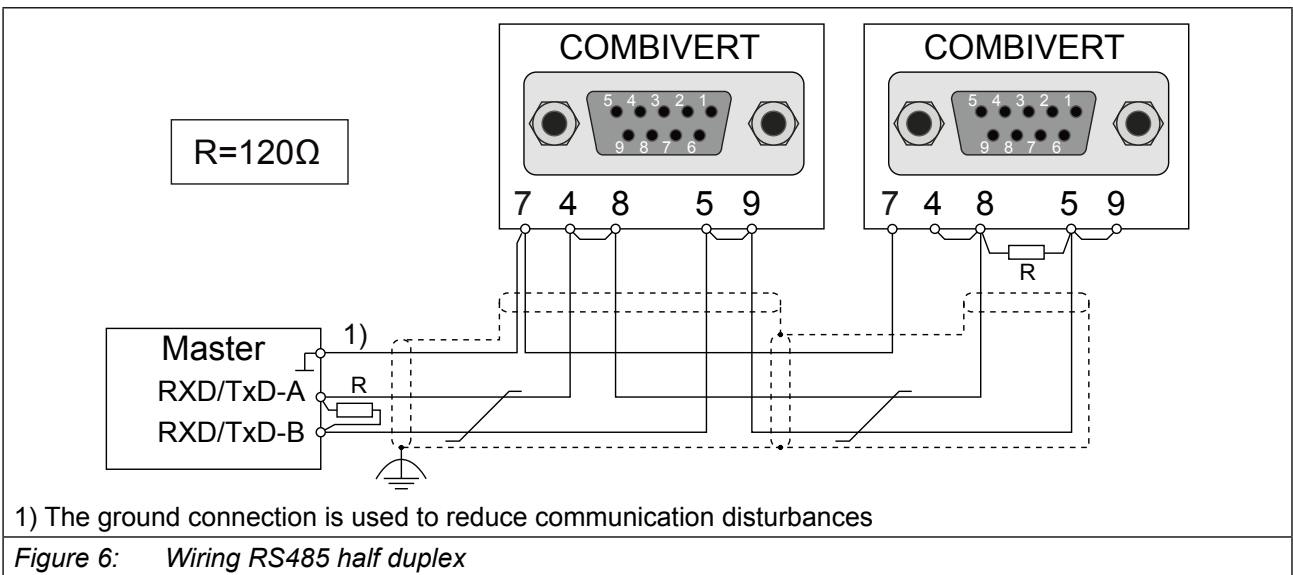

Although the functional earth is connected correctly potential differences between the bus nodes can occur at long lines which disturb the communication. To avoid the interface from destruction by high circulating current based on this, potential differences can be reduced by connection of an additionally ground line between the controls (0V terminal). To avoid interference coupling into the signal line, lay these additionally ground cable outside of the bus line!

3.3.3 Control terminal strip X2A

The control terminal strip is designed as a double, plug-in terminal strip with spring cage connection. It contains 32 pole. The following instructions must be observed at connection:

**Attention**

**Prevent EMC malfunctions**

- Use shielded / drilled cables.
- Lay shield on one side of the inverter onto earth potential.
- Lay control and power cable separately (about 10...20 cm apart); Lay crossings in a right angle (in case it cannot be prevented).

3.3.3.1 Assembly of the wires

Assembly of connecting wires with wire-end ferrules according to DIN46228/4			Assembly of connecting wires without wire-end ferrules	
Cross-section / AWG	Metal sleeve length	Stripping length	Cross-section	Stripping length
0.50 mm <sup>2</sup> / 21	10 mm	12 mm	0.14...1.5 mm <sup>2</sup> / 25...16	10 mm
0.75 mm <sup>2</sup> / 19	12 mm	14 mm	Connecting wires rigidly and flexible	
1.00 mm <sup>2</sup> / 18	12 mm	15 mm		

Table 5: Assembly of the wires

- Press pusher by hand. Insert connecting wires into the respective hole, that no single wires can be seen from the outside or bend outward. A first resistance must be overcome when inserting. Release the pusher.
- Check that the connecting wire is fixed and can not be pulled-out. It is important to ensure that the connecting wire and not the insulation is clamped. The connecting wire can also be inserted without pressing the pusher in case of cross-sections up to 1.00 mm<sup>2</sup>.

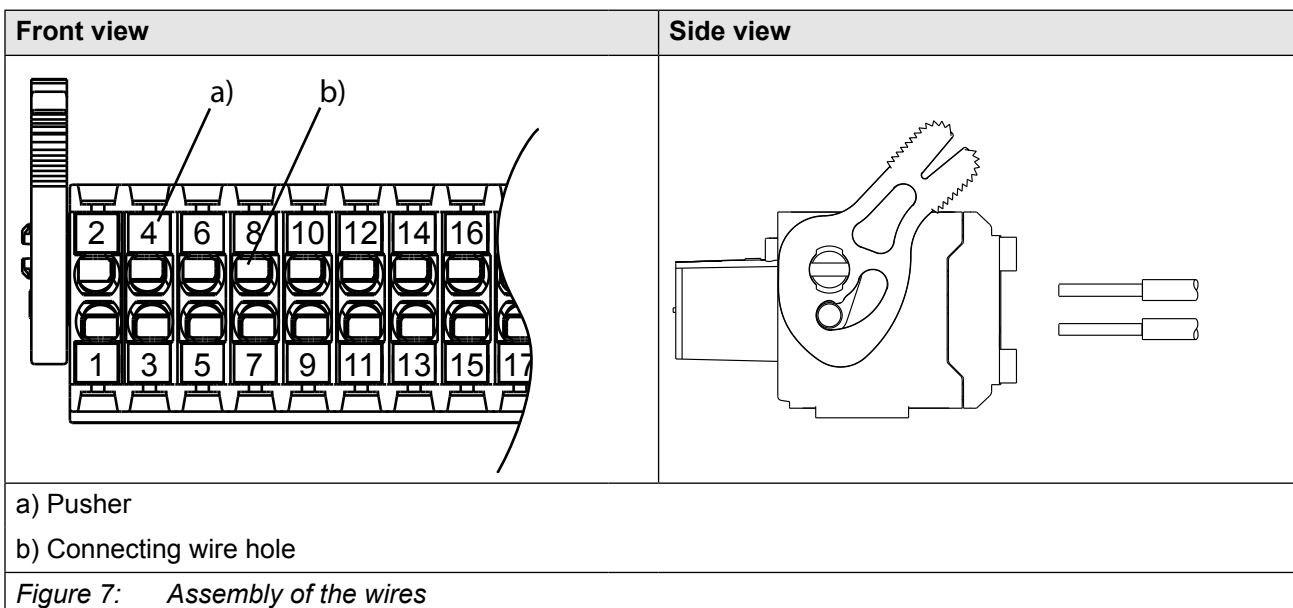

**Attention**

A safe clamping can not be guaranteed when using shorter wire-end ferrules.



KEB generally recommends the use of wire-end ferrules in industrial environments.

## 3.3.3.2 Assignment of the terminal strip X2A

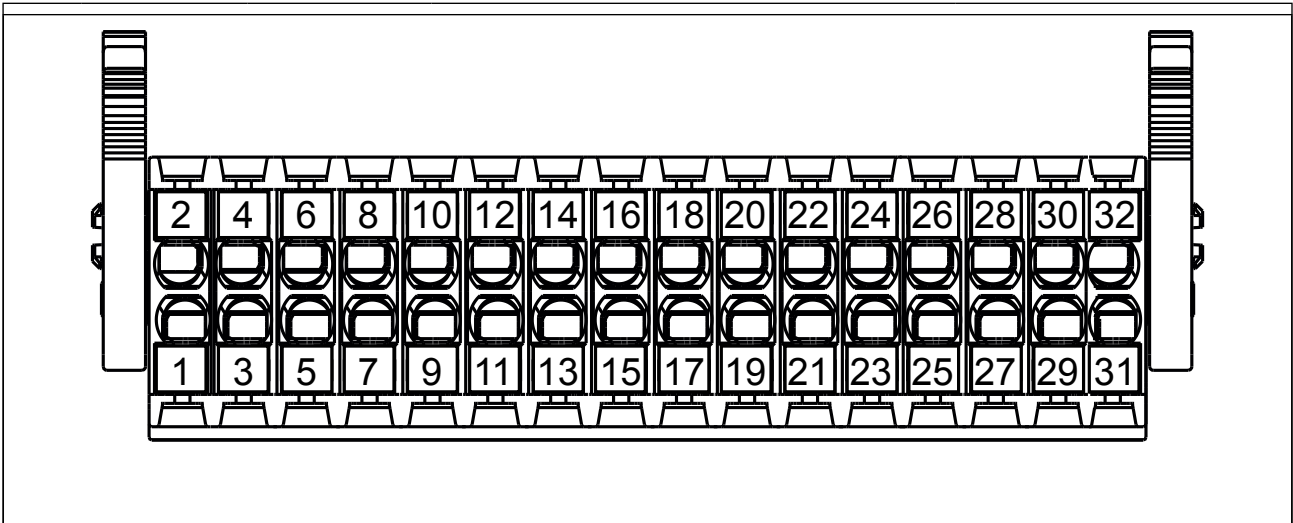

PIN	Name	Description	Specifications
1	0V	Digital mass; 0V reference potential for digital inputs/outputs and $U_{in}$	
2	$U_{in}$	Input external voltage supply	$U=24\text{VDC} +20\%/-15\%$ $I_{max}=400\text{mA}$
3	0V	like pin 1	
4	$U_{out}$	Voltage output for the control of the digital inputs	$U=24\text{VDC} \pm 25\%$ $I_{max}=100\text{mA}$
5	RST	reset	8 digital inputs according to IEC61131-2 type 1 „0“ = -3...5VDC „1“ = 15...30VDC Scan time $\leq 2\text{ms}$
6	ST <sup>1)</sup>	Control release	
7	R	Reverse direction of rotation	
8	F	Forward direction of rotation	
9	I2	Digital input 2	
10	I1	Digital input 1	
11	I4	Digital input 4	
12	I3	Digital input 3	

continued on the next page

Table 6: Assignment of the terminal strip X2A

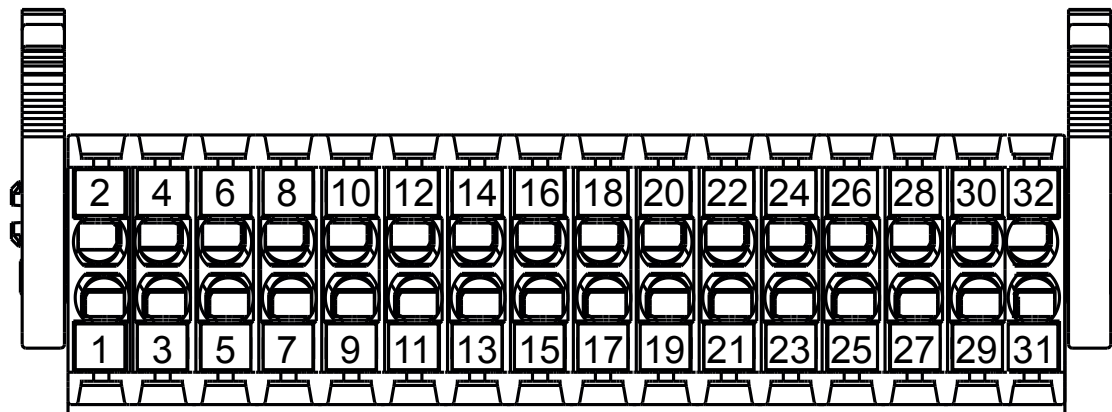

PIN	Name	Description	Specifications	
13	O2	Digital output 2	2 digital transistor outputs PNP U=24 VDC ±25% I <sub>max</sub> =50 mA ohmic load for O1+O2 max switching frequency = 250 Hz	
14	O1	Digital output 1		
15	0V	Like pin 1		
16	–	Terminals 16...24 have no function in this control card.		
17	–			
18	–			
19	–			
20	–			
21	–			
22	–			
23	–			
24	–			
25	R2-C	Relay 2	Switching contact (actual value>level)	U <sub>max</sub> = 30 VDC  I = 0.01...1A 10 <sup>8</sup> mechanically 500.000 at 1A / 30 V DC Ohmic load
26	R1-C	Relay 1	Switching contact (CP.33; error relay)	
27	R2-B	Relay 2	NC contact	
28	R1-B	Relay 1	NC contact	
29	R2-A	Relay 2	NO contact	
30	R1-A	Relay 1	NO contact	
31	–		Without function	
32	–		Without function	
1)	The control release (terminal ST) is without function for units with safety function STO.			

3.3.3.3 Connection of the digital inputs

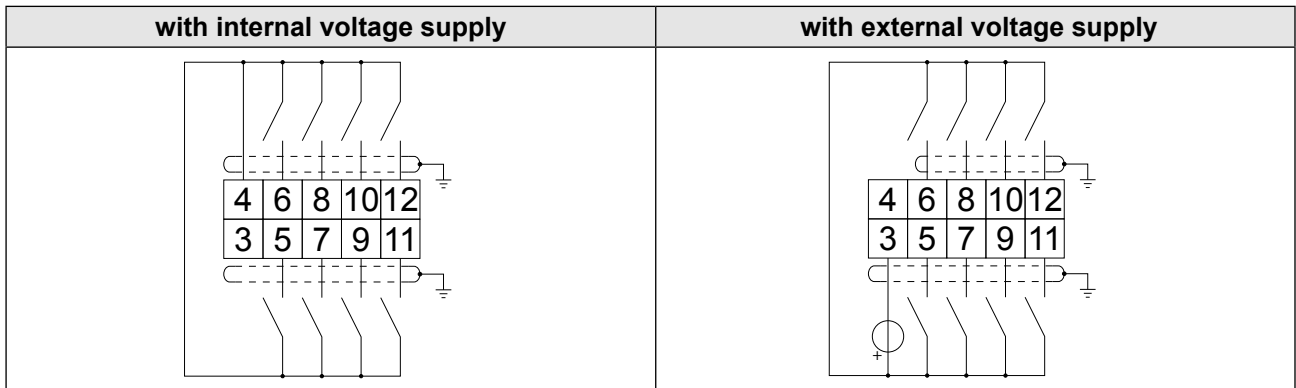

Figure 8: Connection of the digital inputs

Input		Factory setting of the digital inputs			
Name	PIN	Open-loop operation		Closed-loop operation	
RST	5	Reset			
ST	6	Control release			
R	7	Reverse direction of rotation			
F	8	Forward direction of rotation			
I1	10	Fixed frequency 1	Fixed frequency 3	Fixed value 1	Fixed value 3
I2	9	Fixed frequency 2		Fixed value 2	
I3	12	External error input (E.EF)			
I4	11	Activates the DC braking		-	

Table 7: Factory setting of the digital inputs

3.3.3.4 Connection of the digital outputs

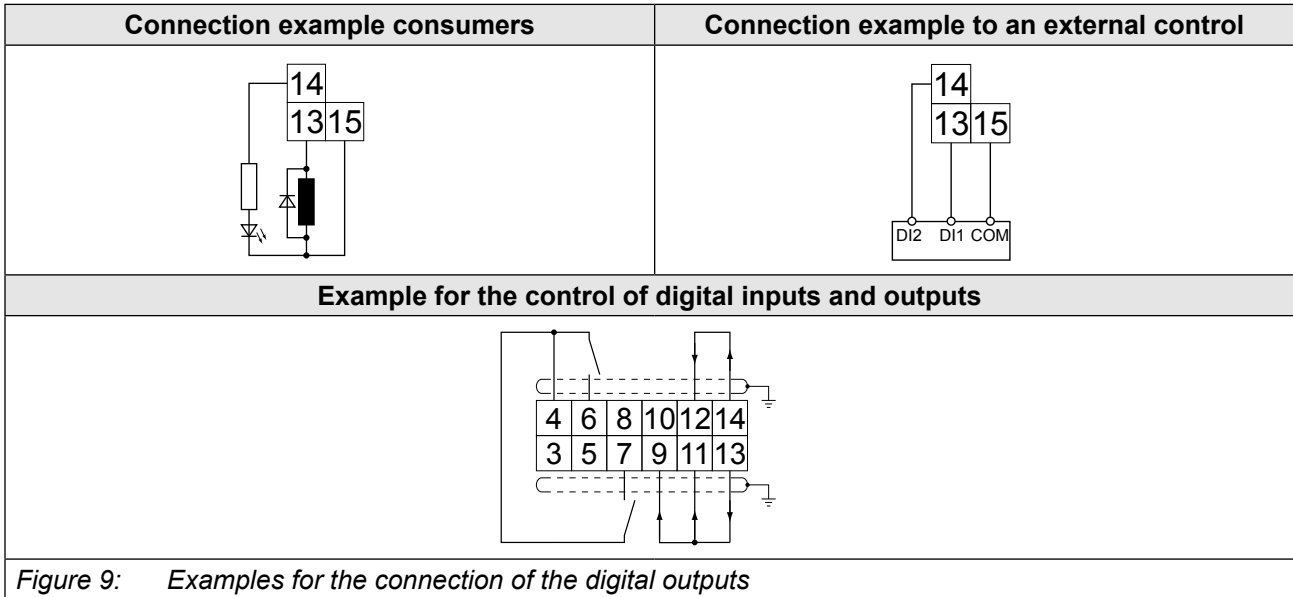

Figure 9: Examples for the connection of the digital outputs

Output		Factory setting of the digital outputs
Name	PIN	
O1	14	Switches at actual value=setpoint
O2	13	Ready signal

Table 8: Factory setting of the digital outputs

3.3.3.5 Connection of the relay outputs

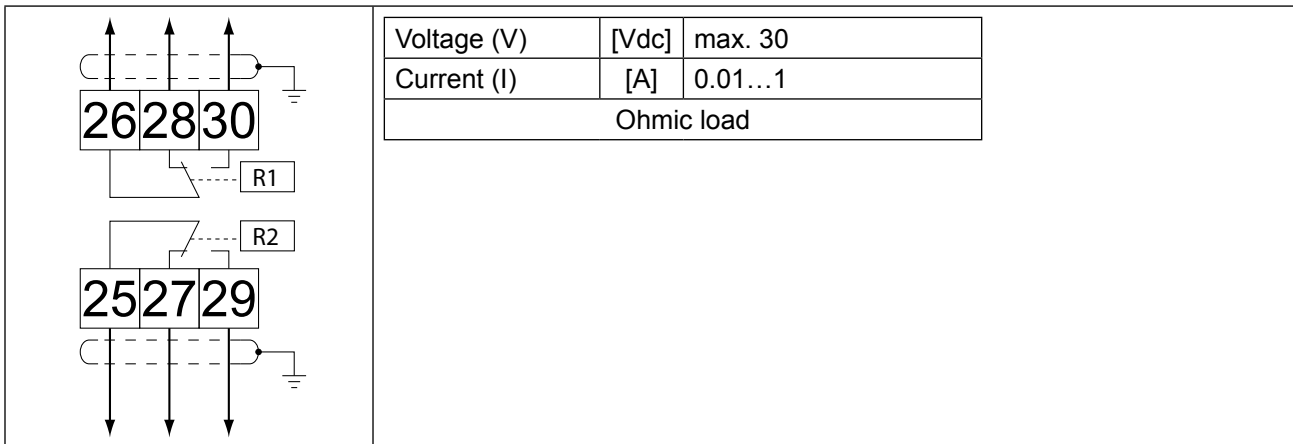

Figure 10: Example for the connection of the relay outputs

Output		Factory setting of the relay outputs	
Name	PIN	Open-loop operation	Closed-loop operation
R1	26/28/30	Fault relay	
R2	25/27/29	Frequency-dependent switch	Run signal

Table 9: Factory setting of the relay outputs



## 4 Parameter Description

On delivery the KEB COMBIVERT G6 is assigned with an user menu, the customer parameters (CP-Parameters). These represent a selection of important parameters for the operation.

Up to a maximum of 48 customer parameters can be defined from over 500 parameters. Only parameter CP00 password input is predefined and can not be modified or deleted.

CP48 software version			
Co-domain	Setting	Description	
0.0.0.0 ... F.F.F.F	–	Display of the software version	
		The first two digits display the major and minor version number (e.g. 1.2.x.x → V1.2)	
		The third digit displays the power unit software (open-loop, ASCL, SCL). Depending therefrom there are different customer parameter menu implemented. The corresponding instruction manuals are shown in the following table.	
		Power unit software	Instruction manual Material number
	x.x.0.x	Power unit open-loop 1st version	00G6N1B-C000
	x.x.1.x	Power unit open-loop 2nd version	00G6N1B-C000
	x.x.2.x	Power unit ASCL	00G6N1B-H000
	x.x.3.x	Power unit SCL	00G6N1B-J000
	The fourth digit displays a serial number for the date code.		

Table 10: Parameter description



The instruction manuals are also available for download on our homepage.

## 5 Profile Parameters

### 5.1 Profile parameters according to DSP301

DSP 301 Addr	Object type	Data type	Attr.	SDO Sub-index	Coding	DSP301 Name	DSP 301 Para.	COMBIVIS available	PD mapable
1000h	var	Uint32	ro	0		DeviceType	co01	yes	no
1001h	var	Uint8	ro	0		ErrorRegister	co02	yes	no
1018h	struct	Uint8	ro	0		Identity object	co04	yes	no
		Uint32	ro	1	14h(KEB)	VendorID	co04	yes	no
		Uint32	ro	2	300000h COMBIVERT G6 Standard	ProductCode	co04	yes	no
		Uint32	ro	3	HighWord OperatorID LowWord PUApplicationID	Revision-Number	co04	yes	no
		Uint32	ro	4	xx	KEB_DeviceSerial-Number	co04	yes	no
1100h	var	Uint16	ro	0		EtherCAT Address	co40	yes	no
1600h	array	Uint8	rw	0	No of mapped objects	receive RDO mapping parameter	co08	yes	no
		Uint32	rw	1	Index / Subindex / Bitlength		co08	yes	no
		Uint32	rw	2	Index / Subindex / Bitlength		co08	yes	no
		Uint32	rw	3	Index / Subindex / Bitlength		co08	yes	no
		Uint32	rw	4	Index / Subindex / Bitlength		co08	yes	no
		Uint32	rw	5	Index / Subindex / Bitlength		co08	yes	no
		Uint32	rw	6	Index / Subindex / Bitlength		co08	yes	no
		Uint32	rw	7	Index / Subindex / Bitlength		co08	yes	no
1A00h	array	Uint8	rw	0	No of mapped objects	transmit PDO mapping parameter	co14	yes	no
		Uint32	rw	1	Index / Subindex / Bitlength		co14	yes	no
		Uint32	rw	2	Index / Subindex / Bitlength		co14	yes	no
		Uint32	rw	3	Index / Subindex / Bitlength		co14	yes	no
		Uint32	rw	4	Index / Subindex / Bitlength		co14	yes	no
		Uint32	rw	5	Index / Subindex / Bitlength		co14	yes	no
		Uint32	rw	6	Index / Subindex / Bitlength		co14	yes	no
		Uint32	rw	7	Index / Subindex / Bitlength		co14	yes	no
Uint32	rw	8	Index / Subindex / Bitlength	co14	yes	no			

continued on the next page

Table 11: Profile parameters according to DSP301

1C00h	struct	Uint8	ro	0 - 4		SyncMan- anagerCom- Type	co45	yes	no
1C10h	var	Uint16	ro	0	0		co46	yes	no
1C11h	var	Uint16	ro	0	0		co47	yes	no
1C12h	struct	Uint16	ro	0	1600h		co48	yes	no
1C13h	struct	Uint16	ro	0	1A00h		co49	yes	no

## 5.2 Profile parameters according to DSP402

Modi	DSP 402 Addr	Object type	File type	Attr.	SDO Sub-index	DSP402 Para.	Unit	DSP402 Name	COMBIVIS available	PD mapable	Instructions		
Device control	603Fh	var		ro	0	pr.63	-	DSP402_Error-Code	yes	yes	no CV plaintext		
	6040h	var		rw	0	pr.64	-	DSP402_Control word	yes	yes			
	6041h	var		ro	0	pr.65	-	DSP402_Status word	yes	yes			
Velocity mode	6042h	var	int16	rw	0	pr.66	rpm	VL_TargetVelocity	yes	yes			
	6043h	var	int16	ro	0	pr.67	rpm	VL_VelocityDemand	yes	yes			
	6044h	var	int16	ro	0	pr.68	rpm	VL_ControlEffort	yes	yes			
	6046h	struct	Uint32	rw	1	-	rpm	VL_VelocityMin	no	no			
			Uint32	rw	2	-	rpm	L_VelocityMax					
	6048h	struct	Uint32	rw	1	-	rpm	VL_AccDspeed					
			Uint16	rw	2	-	s	VL_AccDtime					
	6049h	struct	Uint32	rw	1	-	rpm	VL_DecDspeed					
			Uint16	rw	2	-	s	VL_DecDtime					
604Ah	var	Uint8	rw	0	pr.74	s	VL_QstopD-speedDtime	yes				yes	
604Dh		Uint8	rw	0	pr.77	-	VL_PoleNo	yes				no	
Device control	6060h	var		rw	0	pr.96	-	DSP402_Modes-OfOperation				yes	no
	6061h	var		ro	0	pr.97	-	DSP402_Modes-OfOperDispl.	yes	yes			

Table 12: Profile parameters according to DSP402



**Austria** | KEB Antriebstechnik Austria GmbH  
Ritzstraße 8 4614 Marchtrenk Austria  
Tel: +43 7243 53586-0 Fax: +43 7243 53586-21  
E-Mail: info@keb.at Internet: www.keb.at

**Belgium** | KEB Automation KG  
Herenveld 2 9500 Geraardsbergen Belgium  
Tel: +32 544 37860 Fax: +32 544 37898  
E-Mail: vb.belgien@kebde Internet: www.keb.de

**Brazil** | KEB Brasil - Local Office  
Rua Dr. Omar Pacheco Souza Riberio, 70  
BR-CEP 13569-430 Portal do Sol, São Carlos Brazil  
Tel: +55 16 31161294 E-Mail: roberto.arias@keb.de

**France** | Société Française KEB SASU  
Z.I. de la Croix St. Nicolas 14, rue Gustave Eiffel  
94510 La Queue en Brie France  
Tel: +33 149620101 Fax: +33 145767495  
E-Mail: info@keb.fr Internet: www.keb.fr

**Germany | Headquarters**  
KEB Automation KG  
Südstraße 38 32683 Barntrup Germany  
Telefon +49 5263 401-0 Telefax +49 5263 401-116  
Internet: www.keb.de E-Mail: info@keb.de

**Germany | Geared Motors**  
KEB Antriebstechnik GmbH  
Wildbacher Straße 5 08289 Schneeberg Germany  
Telefon +49 3772 67-0 Telefax +49 3772 67-281  
Internet: www.keb-drive.de E-Mail: info@keb-drive.de

**Italia** | KEB Italia S.r.l. Unipersonale  
Via Newton, 2 20019 Settimo Milanese (Milano) Italia  
Tel: +39 02 3353531 Fax: +39 02 33500790  
E-Mail: info@keb.it Internet: www.keb.it

**Japan** | KEB Japan Ltd.  
15 - 16, 2 - Chome, Takanawa Minato-ku  
Tokyo 108 - 0074 Japan  
Tel: +81 33 445-8515 Fax: +81 33 445-8215  
E-Mail: info@keb.jp Internet: www.keb.jp

**P.R. China** | KEB Power Transmission Technology (Shanghai) Co. Ltd.  
No. 435 QianPu Road Chedun Town Songjiang District  
201611 Shanghai P.R. China  
Tel: +86 21 37746688 Fax: +86 21 37746600  
E-Mail: info@keb.cn Internet: www.keb.cn

**Republic of Korea** | KEB Automation KG  
Room 1709, 415 Missy 2000 725 Su Seo Dong  
Gangnam Gu 135- 757 Seoul Republic of Korea  
Tel: +82 2 6253 6771 Fax: +82 2 6253 6770 E-Mail: vb.korea@keb.de

**Russian Federation** | KEB RUS Ltd.  
Lesnaya str, house 30 Dzerzhinsky MO  
140091 Moscow region Russian Federation  
Tel: +7 495 6320217 Fax: +7 495 6320217  
E-Mail: info@keb.ru Internet: www.keb.ru

**Spain** | KEB Automation KG  
c / Mitjer, Nave 8 - Pol. Ind. LA MASIA  
08798 Sant Cugat Sesgarrigues (Barcelona) Spain  
Tel: +34 93 8970268 Fax: +34 93 8992035 E-Mail: vb.espana@keb.de

**United Kingdom** | KEB (UK) Ltd.  
5 Morris Close Park Farm Industrial Estate  
Wellingborough, Northants, NN8 6 XF United Kingdom  
Tel: +44 1933 402220 Fax: +44 1933 400724  
E-Mail: info@keb.co.uk Internet: www.keb.co.uk

**United States** | KEB America, Inc  
5100 Valley Industrial Blvd. South  
Shakopee, MN 55379 United States  
Tel: +1 952 2241400 Fax: +1 952 2241499  
E-Mail: info@kebameric.com Internet: www.kebameric.com



**MORE KEB PARTNERS WORLDWIDE:**

[www.keb.de/company/representatives-agencies](http://www.keb.de/company/representatives-agencies)



**Automation with Drive**

**[www.keb.de](http://www.keb.de)**

KEB Automation KG · Südstraße 38 · 32683 Barntrop · Tel. +49 5263 401-0 · E-Mail: [info@keb.de](mailto:info@keb.de)