

COMBIVERT

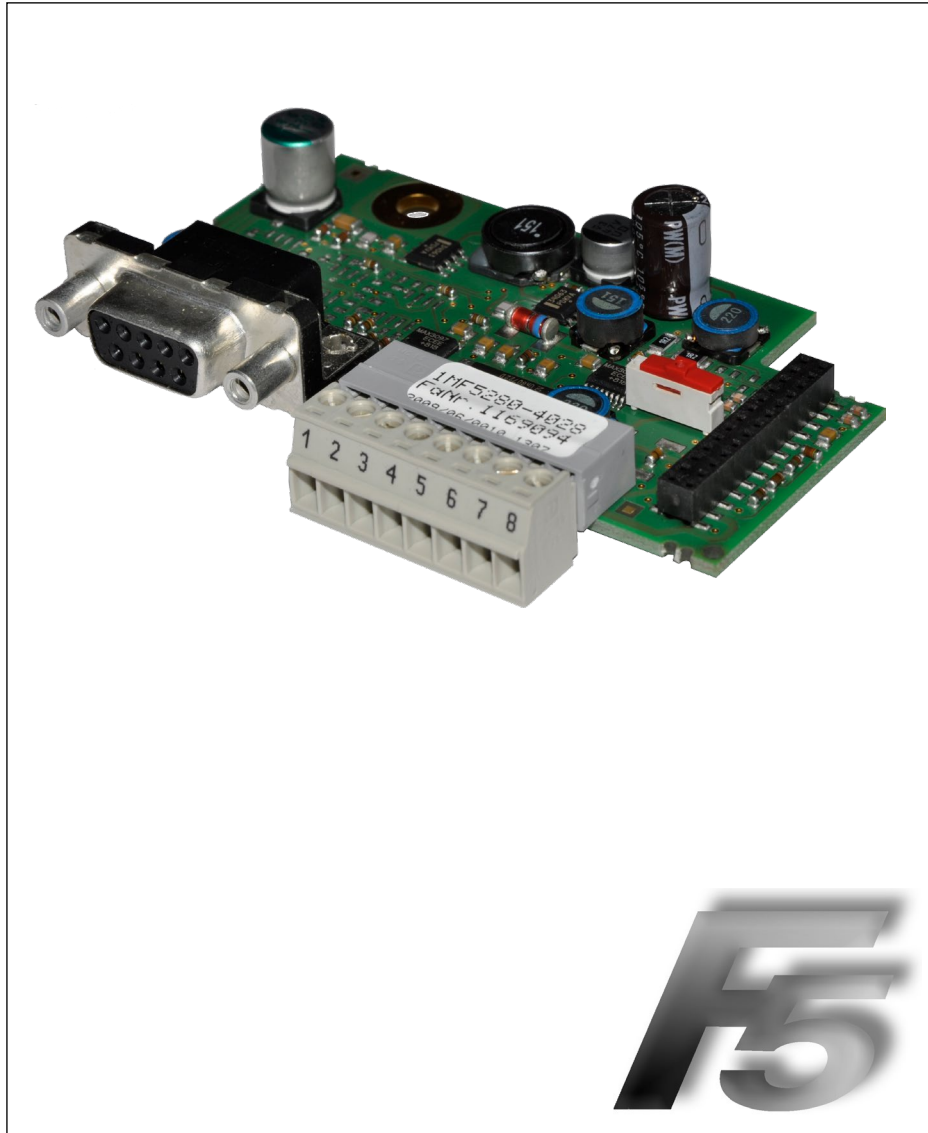

F5

GB INSTRUCTION MANUAL

Encoder Interface

Channel 1

HTL without inverted signals

Channel 2

variable

Mat.No.	Rev.
DLF5ZEM-K070	1B

KEB

1. Safety Instructions	4
1.1 Validity	4
1.2 Qualification.....	4
2. Product Description.....	5
2.1 General.....	5
2.2 Material number	5
2.3 Scope of delivery (option or replacement delivery)	5
2.4 Mechanical installation	6
3. Description of the Interface	6
3.1 Setting the voltage supply	6
3.2 Description of channel 1	7
3.2.1 Specifications of channel 1.....	7
3.2.2 Description of X3A.....	8
3.2.3 Assignment of X3A.....	8
3.2.4 Input signals	8
3.2.4.1 Signal tracks A and B	8
3.2.4.2 Evaluation of the Zero Signal	9
3.2.5 Encoder breakage recognition	9
3.2.6 Connection of the encoder	10
3.2.6.1 Encoder cable at terminal strip X3A.....	10
3.2.7 Encoder cable	10
3.2.8 Encoder line length.....	10
3.2.9 Tested encoders.....	11
3.3 Description of channel 2.....	11
4. Start-up	11
5. Error Messages.....	11

Safety Instructions

1. Safety Instructions

Prior to performing any work on the unit the user must familiarize himself with the unit. This includes especially the knowledge and observance of the safety and warning directions. The pictographs used in this instruction manual have following meaning:

	Danger	Refers to danger of life by electric current.
---	--------	---

	Warning	Refers to possible danger of injury or life.
---	---------	--

	Note	Refers to tips and additional information.
---	------	--

1.1 Validity

The information contained in the technical documentation, as well as any user-specific advice in spoken and written and through tests, are made to best of our knowledge and information about the application. However, they are considered for information only without responsibility. This also applies to any violation of industrial property rights of a third-party.

Inspection of our units in view of their suitability for the intended use must be done generally by the user. Inspections are particularly necessary, if changes are executed, which serve for the further development or adaption of our products to the applications (hardware, software or download lists). Inspections must be repeated completely, even if only parts of hardware, software or download lists are modified.

	Controlling by the user	Application and use of our units in the target products is outside of our control and therefore lies exclusively in the area of responsibility of the user.
---	-------------------------	---

	Use under special conditions	The used semiconductors and components of KEB are developed and dimensioned for the use in industrial products. If the KEB COMBIVERT is used in machines, which work under exceptional conditions or if essential functions, life-supporting measures or an extraordinary safety step must be fulfilled, the necessary reliability and security must be ensured by the machine builder.
---	------------------------------	---

1.2 Qualification

All operations serving transport, installation and commissioning as well as maintenance are to be carried out by skilled technical personnel (observe IEC 364 or CENELEC HD 384 or DIN VDE 0100 and national accident prevention rules!). According to this manual qualified staff means those who are able to recognise and judge the possible dangers based on their technical training and experience and those with knowledge of the relevant standards and who are familiar with the field of power transmission (VDE 0100, VDE 0160 (EN 50178), VDE 0113 (EN 60204) as well as the appropriate regulations for your area.

	Danger by high voltage	KEB electronics components contain dangerous voltages which can cause death or serious injury. In operation, drive converters, depending on their degree of protection, may have live, uninsulated, and possibly also moving and hot surfaces. In case of inadmissible removal of the required covers, of improper use, wrong installation or maloperation, there is the danger of serious personal injury and damage to property.
---	------------------------	--

2. Product Description

Figure 2: Incremental encoder HTL without inverted signals on channel 1	
For housing size D and E	
X3B Channel 2 see material number	X3A Channel 1 without inverse signals

2.1 General

Each of the interface cards delivered by KEB include two interfaces. As there are numerous different combinations available each interface will be described by means of separate instructions. The instruction covers the installation of the interface card, the connection as well as the start-up of a suitable encoder. Further information and the parameter adjustments are described in the application manual for the inverter/servo.

2.2 Material number

xM	F5	K81	X	X	X	X
		Term of delivery	0	installed	Z	Option, spare part
		Interface	S	TTL-output	4029	T TTL-input 4028
			F5	Series		
applicable for housing size		1M	D, E (circuit board 1MF5280-xxxx see above)			

2.3 Scope of delivery (option or replacement delivery)

- Encoder interface
- two instruction manuals
- fixing bolt
- packing material

2.4 Mechanical installation

All kind of works on the inverter may be carried out by authorized personnel in accordance with the EMC and safety rules only.

- Switch inverter de-energized and await capacitor discharge time
- Pull off operator
- Remove plastic cover
- Remove fixing bolt
- Fix interface board beginning from the socket connector straightly
- Screw in fixing bolt
- Attach plastic cover

3. Description of the Interface

3.1 Setting the voltage supply

Figure 3.1.a: Setting the encoder voltage by the DIL switch S1

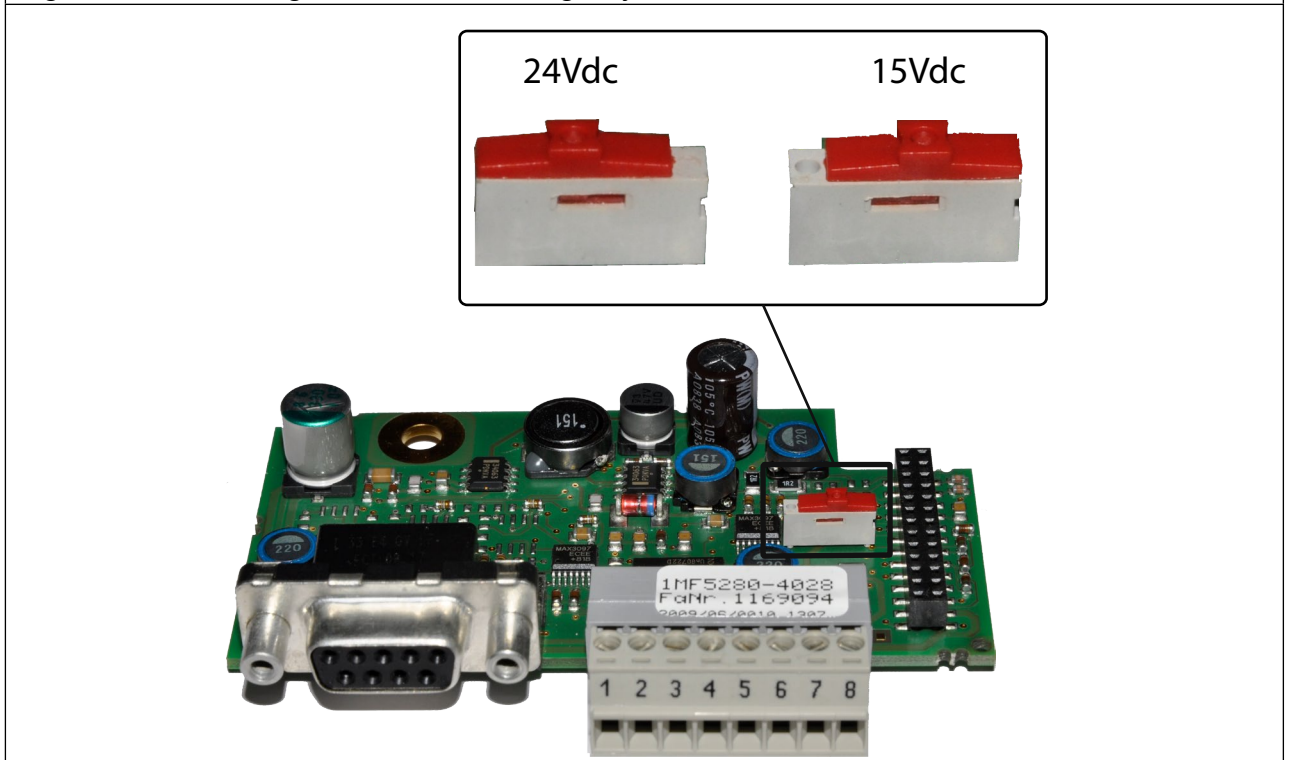

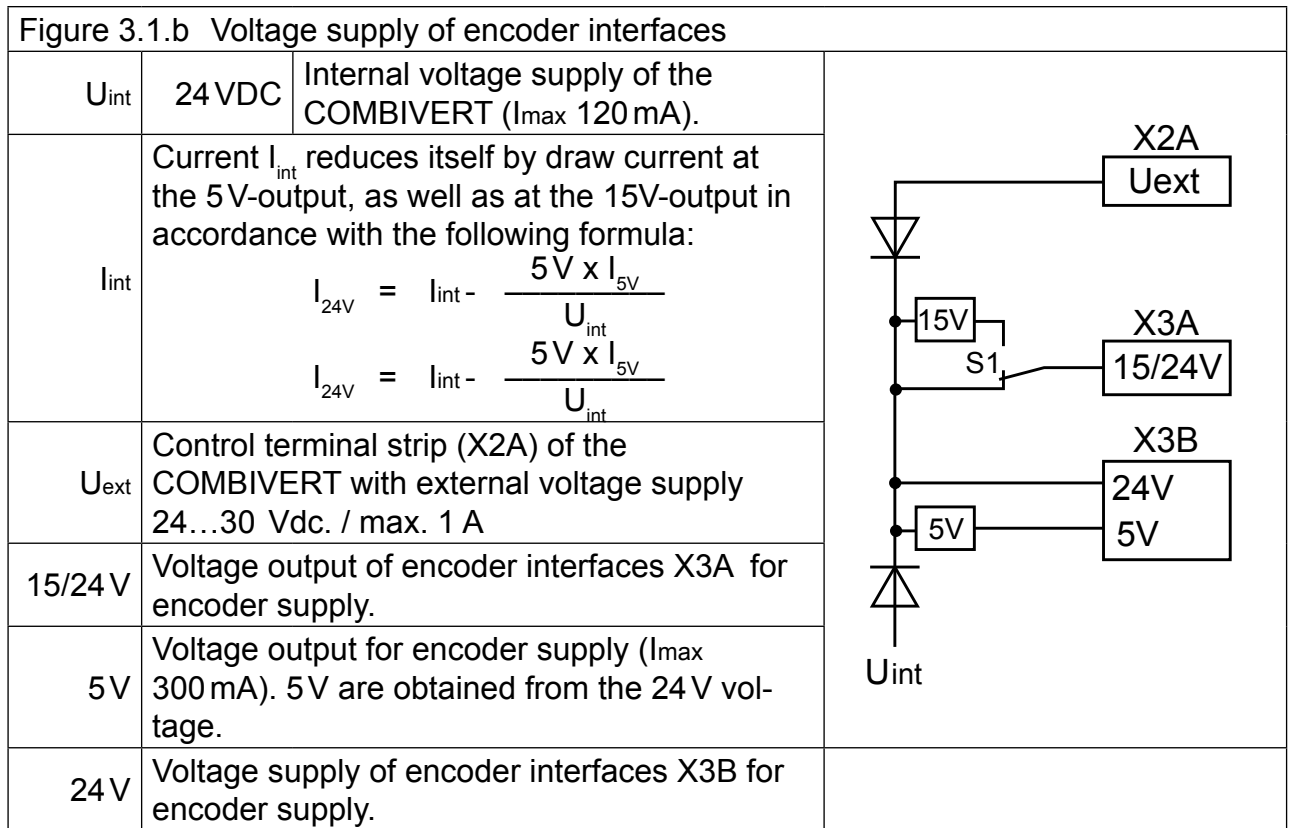

3.2 Description of channel 1

3.2.1 Specifications of channel 1

Interface type	Incremental Encoder Input
Input signals	HTL 15...30V without inverse signals
Inputs / tracks	A+, B+, N+
Output	Voltage output 15/24 V for encoder supply
Particularities	Encoder breakage recognition for all signals
Limiting frequency	100kHz
Increments per revolution	1...16383 inc (recommendation 2500 inc for speed upto 2400 rpm)
Input resistance	3.9kΩ at 24 V input voltage
Max. line length	50 m, the value is additionally limited by the signal frequency, cable capacity and supply voltage (see chapter „encoder line length“).

3.2.2 Description of X3A

Version	plug in terminal block
Terminals	8
Tightening torque	0.22...0.25 Nm
permissible cable cross-section	0.14...1.5mm ²
Stripping length	7 mm

	Terminal assign- ment changed	The pin assignment has changed in relation to the previ- ous version.
---	----------------------------------	--

3.2.3 Assignment of X3A

Figure 3.2.3 Description of terminal strip X3A

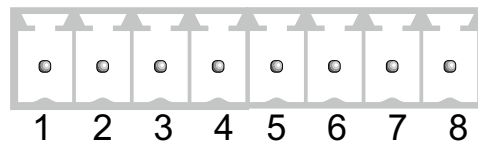

PIN	Name	Description
1	A+	Encoder track A HTL signal+
2	-	n.c.
3	B+	Encoder track B HTL signal+
4	-	n.c.
5	N+	Zero track HTL signal+
6	-	n.c.
7	15/24V	switchable voltage supply for encoder
8	COM	Reference potential for signals and voltage supply

3.2.4 Input signals

3.2.4.1 Signal tracks A and B

In case of HTL-encoder interface the signals A+ and B+ are rectangular signals with a phase-angle displacement by 90 degrees. The inverted signals will be generated internally and does not need to be provided by the encoder.

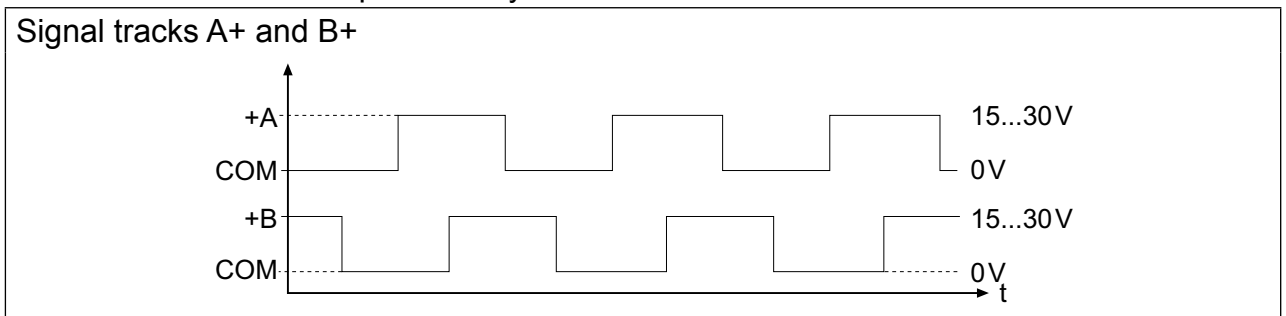

3.2.4.2 Evaluation of the Zero Signal

The zero impulse is required to determine valid position points. In case of pure speed controls the signal does not need to be connected. In the following signal sequence the maximum permissible length of the zero impulse of the encoder is visible. The zero signal will be acquired if A+ ,B+ and N+ are at high level. By that there is only one valid position point which is independent from the travel direction.

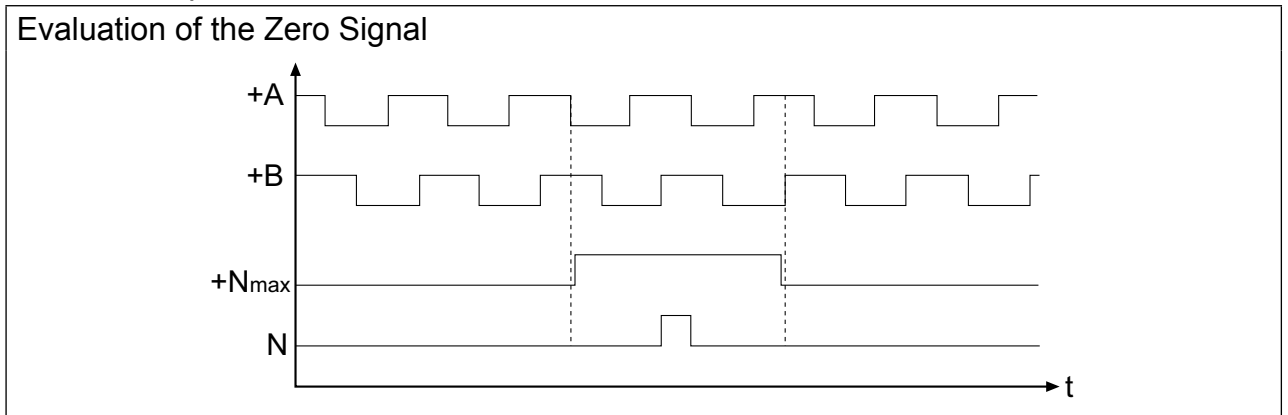

3.2.5 Encoder breakage recognition

For a monitoring of the encoder and the encoder cable the signal tracks and the zero track are monitored. Input N+ must be connected with input 15/24V if the connected encoder should not have a zero track. The monitoring for channel 1 will be switched on/off with parameter Ec.42 (in the past Ec.20). The recognition of encoder breakage triggers an „error!“ encoder 1“ (value 32), if the voltage at the signal input is smaller than 6V.

Parameter	r/w	Enter	prog.
Ec.42 Encoder alarm mode	yes	no	no
Dependent on Ec.42 „Error! Encoder 1“ (value 32) or a warning is triggered, if the permissible signal levels are fallen below.			
Setting range	Setting	Meaning	
0	1	Encoder monitoring off	
1		Encoder monitoring on	
2		Encoder monitoring on (open-loop off)	
3		Warning	

3.2.6 Connection of the encoder

3.2.6.1 Encoder cable at terminal strip X3A

- Encoder cable double-shielded and twisted in pairs
- Connect exterior shielding at both ends to PE/GND
- Connect interior shieldings at one side to COM
- Do not connect exterior and interior shielding
- N+ is only required for posi function

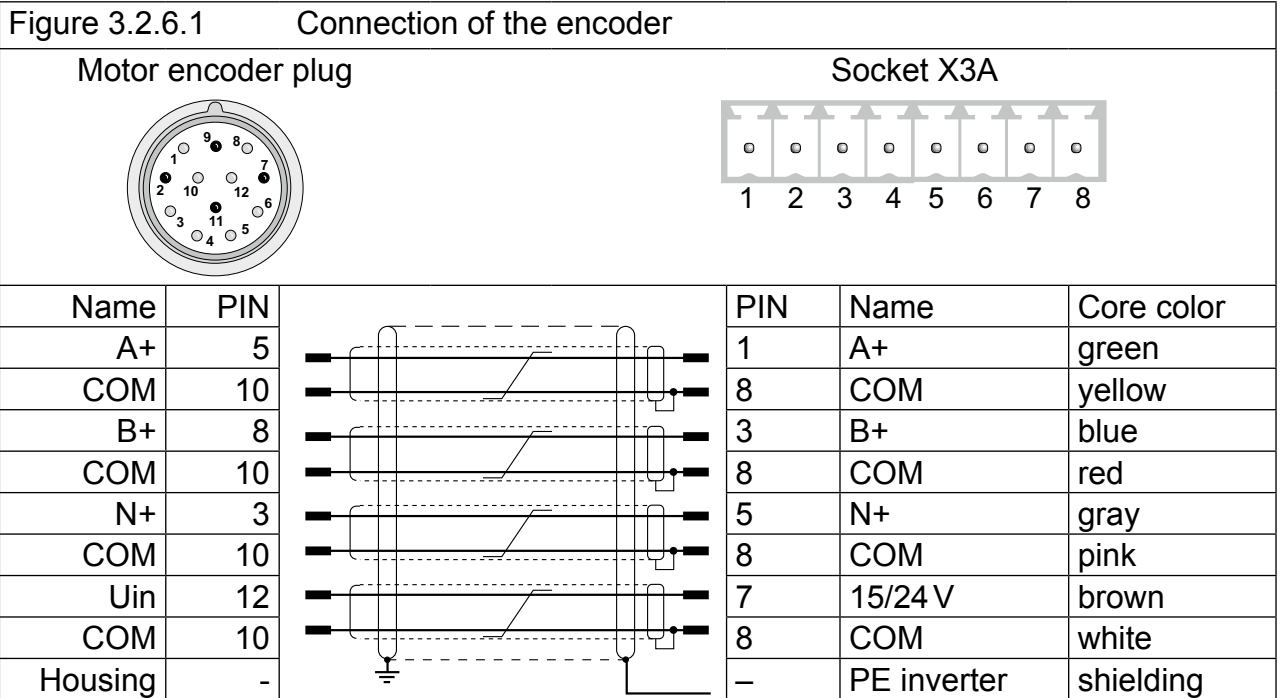

3.2.7 Encoder cable

KEB encoder cables are corresponding to the following specification:

Signal lines	3 x (2 x 0,14 mm ²)
Supply lines	2 x 0,5 mm ²
Particularities	trailing capable, oil-resistant
Temperature range	constant up to 80 °C
Color	green RAL 6018

3.2.8 Encoder line length

The maximum line length of the encoder cable is 50 m. It results from the voltage drop of the supply line. The value is calculated as follows:

Encoder cable length =	$\frac{U - U_{\min}}{I_{\max} \cdot 2 \cdot R}$
max. encoder current I_{\max} :	see encoder description
Supply voltage U:	15 V or 24 V
minimum input voltage U_{\min} :	see encoder description
KEB encoder cable resistance R:	0,036 Ω/m at 0,5 mm ²

3.2.9 Tested encoders

The following encoder can be used dependent on the interface and the control:

Manufacturer	Type	Encoder type
Heidenhain	• ROD436	HTL-Incremental Encoder

However, this does not restrict the use of rotary encoder with same specifications of other manufacturers.

3.3 Description of channel 2

The description of input X3B is depending on the used encoder interface. It is described in a separate manual.

4. Start-up

After the installation or exchange of an encoder interface some adjustments of the inverter/servo software have to be done before operation:

- Switch on inverter
- Select application mode
- Select parameter Ec.00 and control whether value „27“ is entered. The displayed value has to be confirmed by „ENTER“ in any case.
- Select Ec.01 and adjust increments per revolution.
- Select Ec.42 (Ec.20 upto V2.8) and adjust the encoder breakage recognition dependent on the case of operation.

5. Error Messages

Error messages and their meaning are described in the application manual.



Error „E.hYb“ can be reset by a Power-On-Reset. Error „E.EncC“ can be reset by writing on parameter Ec.00 and additional also be reset by a Hardware-Reset or Bus-Reset (control word) since software version 4.1.



KEB Automation KG

Südstraße 38 • 32683 Barntrup
fon: +49 5263 401-0 • fax: +49 5263 401-116
net: www.keb.de • mail: info@keb.de

KEB worldwide...

KEB Antriebstechnik Austria GmbH

Ritzstraße 8 • 4614 Marchtrenk
fon: +43 7243 53586-0 • fax: +43 7243 53586-21
net: www.keb.at • mail: info@keb.at

KEB Antriebstechnik

Herenveld 2 • 9500 Geraardsbergen
fon: +32 5443 7860 • fax: +32 5443 7898
mail: vb.belgien@keb.de

KEB Power Transmission Technology (Shanghai) Co.,Ltd.

No. 435 Qianpu Road, Chedun Town, Songjiang District,
Shanghai 201611, P.R. China
fon: +86 21 37746688 • fax: +86 21 37746600
net: www.keb.de • mail: info@keb.cn

KEB Antriebstechnik Austria GmbH

Organizační složka
Suchovrbenske nam. 2724/4 • 370 06 České Budějovice
fon: +420 387 699 111 • fax: +420 387 699 119
mail: info@keb.cz

KEB Antriebstechnik GmbH

Wildbacher Str. 5 • 08289 Schneeberg
fon: +49 3772 67-0 • fax: +49 3772 67-281
mail: info@keb-drive.de

KEB España

C/ Mitjer, Nave 8 - Pol. Ind. LA MASIA
08798 Sant Cugat Sesgarrigues (Barcelona)
fon: +34 93 897 0268 • fax: +34 93 899 2035
mail: vb.espana@keb.de

Société Française KEB

Z.I. de la Croix St. Nicolas • 14, rue Gustave Eiffel
94510 LA QUEUE EN BRIE
fon: +33 1 49620101 • fax: +33 1 45767495
net: www.keb.fr • mail: info@keb.fr

KEB (UK) Ltd.

Morris Close, Park Farm Industrial Estate
Wellingborough, NN8 6 XF
fon: +44 1933 402220 • fax: +44 1933 400724
net: www.keb.co.uk • mail: info@keb.co.uk

KEB Italia S.r.l.

Via Newton, 2 • 20019 Settimo Milanese (Milano)
fon: +39 02 3353531 • fax: +39 02 33500790
net: www.keb.de • mail: kebitalia@keb.it

KEB Japan Ltd.

15-16, 2-Chome, Takanawa Minato-ku
Tokyo 108-0074
fon: +81 33 445-8515 • fax: +81 33 445-8215
mail: info@keb.jp

KEB Korea Seoul

Room 1709, 415 Missy 2000
725 Su Seo Dong, Gang Nam Gu
135-757 Seoul/South Korea
fon: +82 2 6253 6771 • fax: +82 2 6253 6770
mail: vb.korea@keb.de

KEB RUS Ltd.

Lesnaya Str. House 30, Dzerzhinsky (MO)
140091 Moscow region
fon: +7 495 632 0217 • fax: +7 495 632 0217
net: www.keb.ru • mail: info@keb.ru

KEB America, Inc.

5100 Valley Industrial Blvd. South
Shakopee, MN 55379
fon: +1 952 224-1400 • fax: +1 952 224-1499
net: www.kebamerica.com • mail: info@kebamerica.com

More and latest addresses at <http://www.keb.de>

© KEB	
Mat.No.	DLF5ZEM-K070
Rev.	1B
Date	03/2017