

COMBIVERT

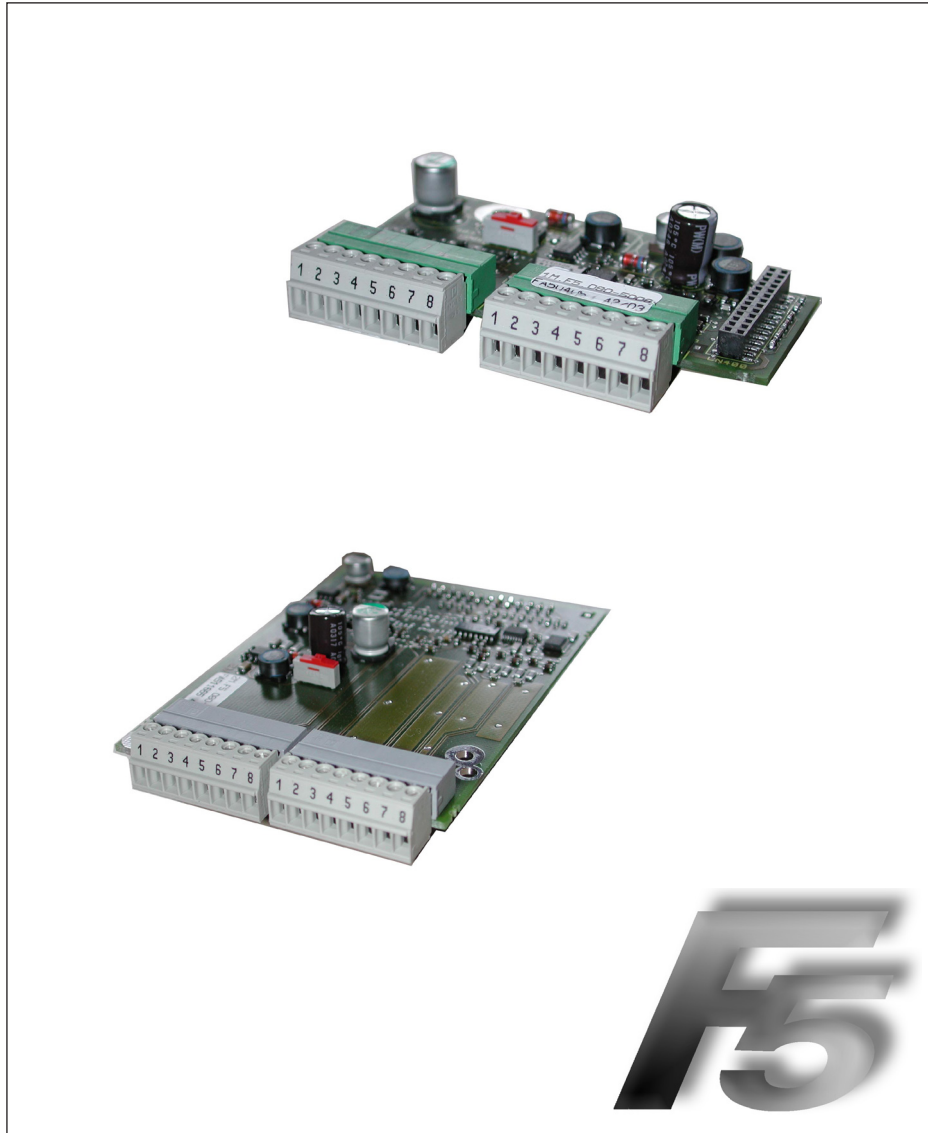

GB INSTRUCTION MANUAL
Channel 1

Incremental encoder
TTL Voltage Supply 15/24V

Mat.No.	Rev.
DKF5ZEM-K030	1B

KEB

1. Safety Instructions	4
1.1 Validity	4
1.2 Qualification.....	4
2. Product description	5
2.1 General.....	5
2.2 Part number.....	5
2.3 Scope of delivery (option or replacement delivery)	5
2.4 Mechanical installation	6
3. Description of the Interface	6
3.1 Power supply.....	6
3.1.1 Adjustment of the Supply Voltage	7
3.2 Channel 1	7
3.2.1 Specification	7
3.2.2 Description of X3A.....	7
3.3.3. Signal input.....	8
3.3.3.1 Input signals of encoder inputs.....	8
3.3.3.2 Evaluation of the Zero Signal	8
3.2.3.3 Encoder breakage recognition	9
3.2.4 Connection of the encoder	9
3.2.4.1 Encoder cable at terminal strip X3A	9
3.2.5 encoder channel.....	10
3.2.6 Encoder line length.....	10
3.2.7 Tested encoder	10
3.3 Channel 2	10
4. Start-up	11
5. Error messages.....	11

1. Safety Instructions

Prior to performing any work on the unit the user must familiarize himself with the unit. This includes especially the knowledge and observance of the safety and warning directions. The pictographs used in this instruction manual have following meaning:



Danger Refers to danger of life by electric current.



Warning Refers to possible danger of injury or life.



Note Refers to tips and additional information.

1.1 Validity

The information contained in the technical documentation, as well as any user-specific advice in spoken and written and through tests, are made to best of our knowledge and information about the application. However, they are considered for information only without responsibility. This also applies to any violation of industrial property rights of a third-party.

Inspection of our units in view of their suitability for the intended use must be done generally by the user. Inspections are particularly necessary, if changes are executed, which serve for the further development or adaption of our products to the applications (hardware, software or download lists). Inspections must be repeated completely, even if only parts of hardware, software or download lists are modified.



Controlling by the user Application and use of our units in the target products is outside of our control and therefore lies exclusively in the area of responsibility of the user.



Use under special conditions The used semiconductors and components of KEB are developed and dimensioned for the use in industrial products. If the KEB COMBIVERT is used in machines, which work under exceptional conditions or if essential functions, life-supporting measures or an extraordinary safety step must be fulfilled, the necessary reliability and security must be ensured by the machine builder.

1.2 Qualification

All operations serving transport, installation and commissioning as well as maintenance are to be carried out by skilled technical personnel (observe IEC 364 or CENELEC HD 384 or DIN VDE 0100 and national accident prevention rules!). According to this manual qualified staff means:

- those who are able to recognise and judge the possible dangers based on their technical training and experience
- those with knowledge of the relevant standards and who are familiar with the field of power transmission (VDE 0100, VDE 0160 (EN 50178), VDE 0113 (EN 60204) as well as the appropriate regulations for your area.



Danger by high voltage KEB electronics components contain dangerous voltages which can cause death or serious injury. In operation, drive converters, depending on their degree of protection, may have live, uninsulated, and possibly also moving and hot surfaces.

In case of inadmissible removal of the required covers, of improper use, wrong installation or maloperation, there is the danger of serious personal injury and damage to property.

2. Product description

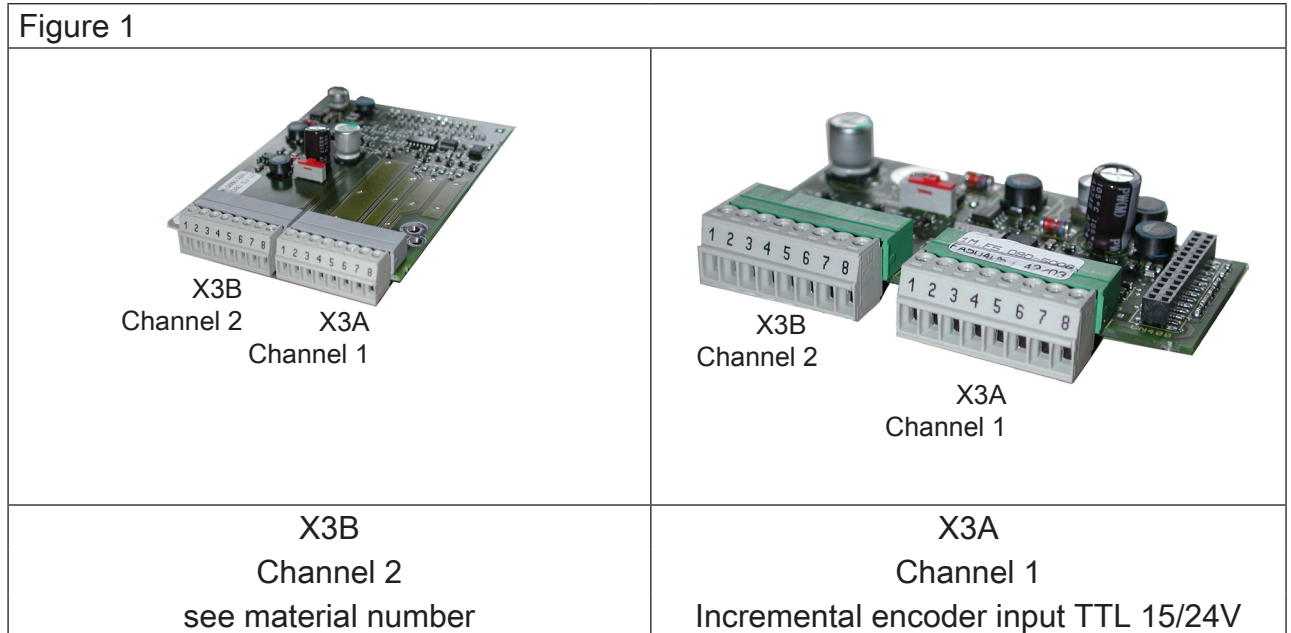

2.1 General

Each of the interface cards delivered by KEB include two interfaces. As there are numerous different combinations available each interface will be described by means of separate instructions. The instruction covers the installation of the interface card, the connection as well as the start-up of a suitable encoder. Further information and the parameter adjustments are described in the application manual for the inverter/servo.

2.2 Part number

2M	F5	K81	X	Z	0	5
----	----	-----	---	---	---	---

Term of delivery	0	installed	Z	Option, spare part
	B	TTL-output	5005	
Encoder interface	F5	Series		
applicable for housing size	1	D, E (circuit board 1M.F5.280-xxxx see above)		
	2	G...U (circuit board 2M.F5.280-xxxx see above)		

2.3 Scope of delivery (option or replacement delivery)

- Encoder interface
- two instruction manuals
- fixing bolt
- packing material

2.4 Mechanical installation

All kind of works on the inverter may be carried out by authorized personnel in accordance with the EMC and safety rules only.

- Switch inverter de-energized and await capacitor discharge time
- Pull off operator
- Remove plastic cover
- Remove fixing bolt
- Fix interface board beginning from the socket connector straightly
- Screw in fixing bolt
- Attach plastic cover

3. Description of the Interface

3.1 Power supply

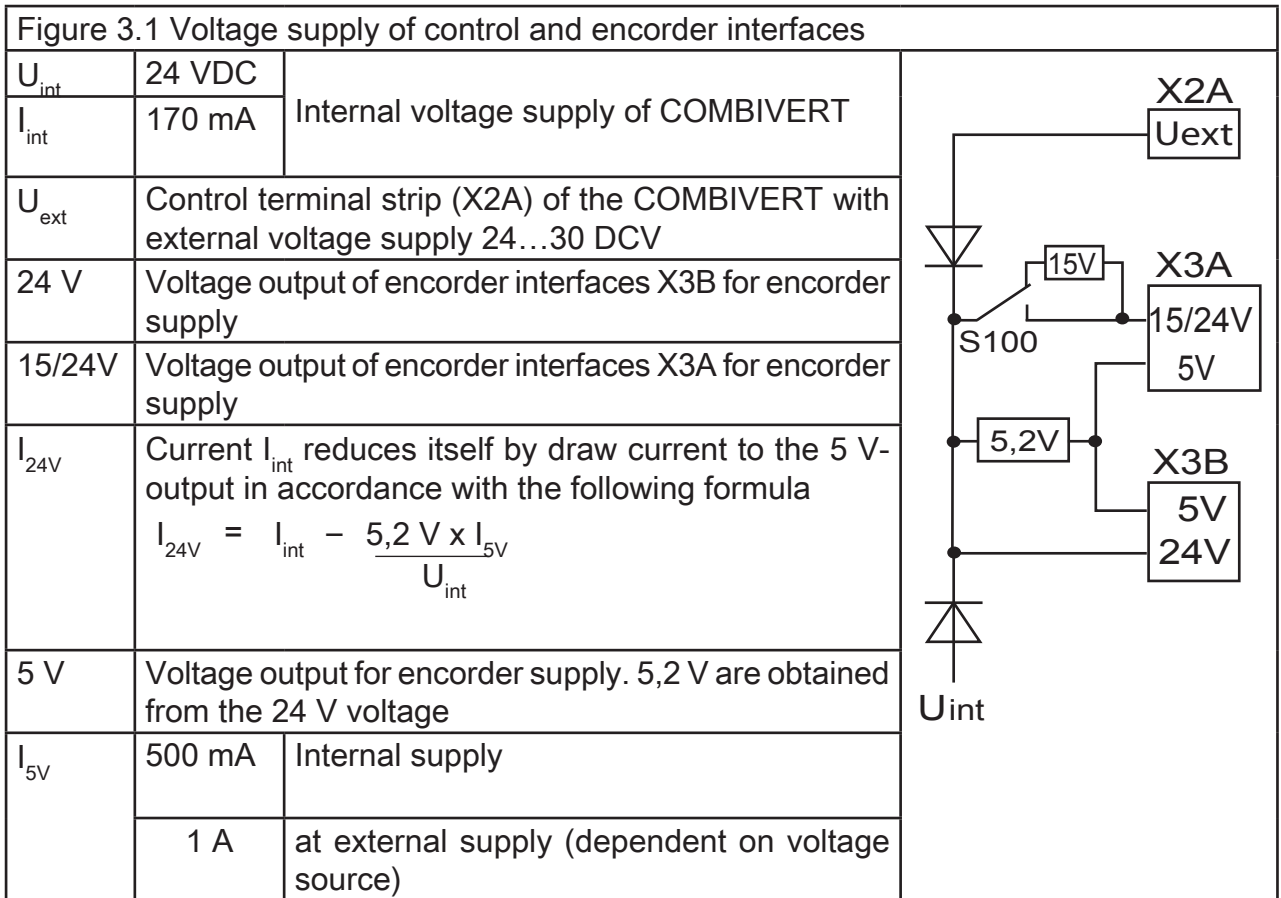

3.1.1 Adjustment of the Supply Voltage

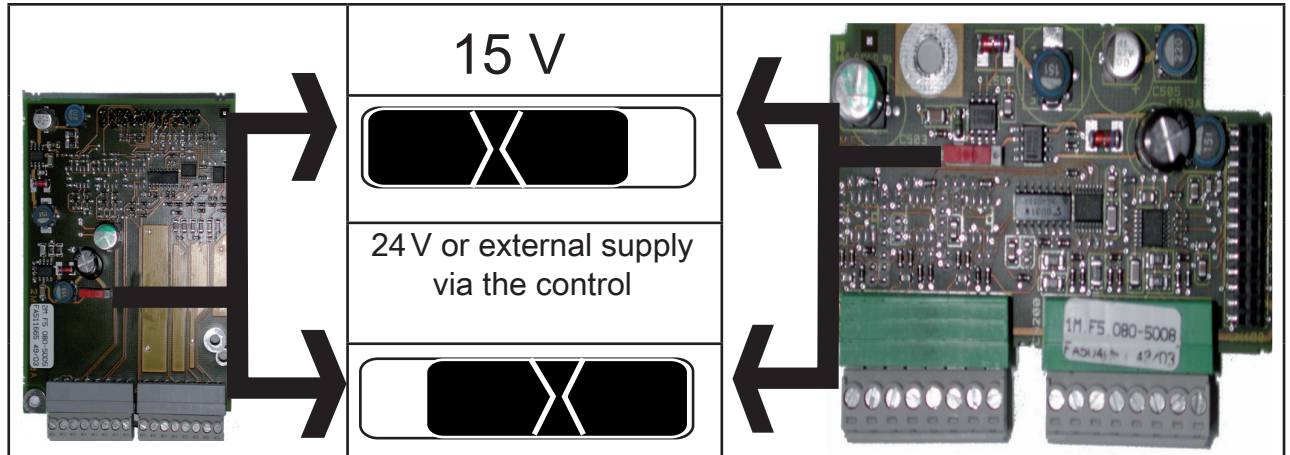

3.2 Channel 1

3.2.1 Specification

X3A	Terminal strip 8-pole
Interface type	Incremental encoder input
Output signals	5V TTL according to RS485
Outputs / tracks	A, B and N with the respective inverted signals
Limiting frequency	300 kHz
encoder line number	1...16383 inc (recommendation 2500 inc for speed upto 4500 rpm)
Input resistance	150 Ω
Max. line length	50 m, the value is additionally limited by the signal frequency, cable capacity and supply voltage.

3.2.2 Description of X3A

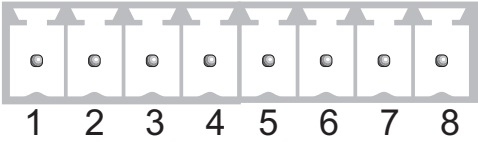
Terminal strip X3A (top view)		
PIN	Name	Description
1	A+	Incremental encoder track A+
2	A-	Signal input A- (difference signal to A+)
3	B+	Incremental encoder track B+
4	B-	Signal input B- (difference signal to B+)
5	N+	Zero track N+
6	N-	Signal input N- (difference signal to N+)
7	15/24 V	Voltage output 15/20...30 V Power supply for encoder switchable by dip switch S100
8	COM	Reference potential for supply voltage

3.3.3. Signal input

3.3.3.1 Input signals of encoder inputs

At the encoder interface TTL input the signals A+ and B+ are electrically phase-shifted by 90° rectangular signals with the respective inverted signals.

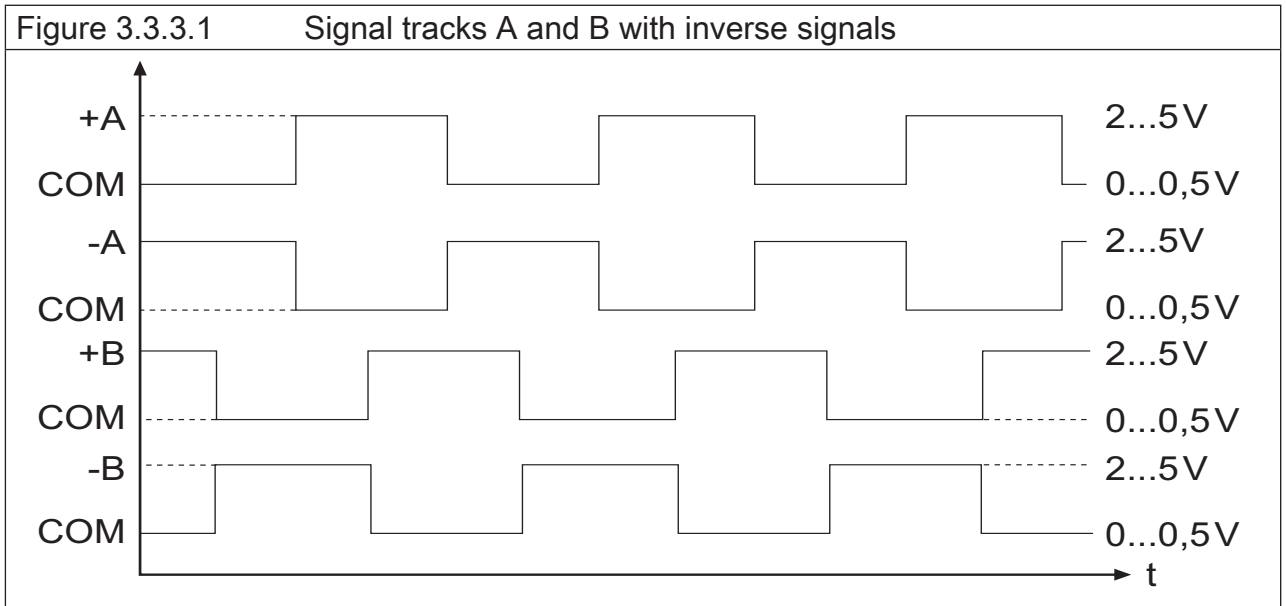

3.3.3.2 Evaluation of the Zero Signal

The zero impulse is required to determine valid position points. In case of pure speed controls the signal does not need to be connected. In the following signal sequence the maximum permissible length of the zero impulse of the encoder is visible. The zero signal is acquired when A+ ,B+ and N+ are on high level. Thus there is only one valid position value independent of the travel direction.

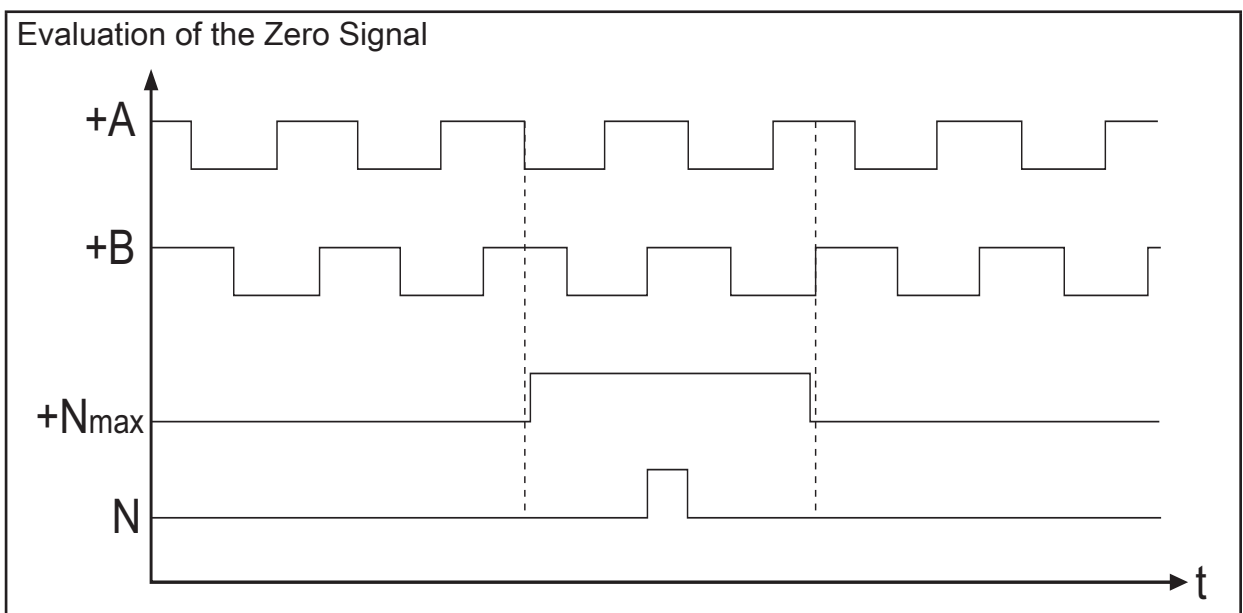

3.2.3.3 Encoder breakage recognition

For a monitoring of the encoder to channel 1 and the encoder cable the signal tracks and the zero track are monitored. If the connected encoder has no zero track, then the the 5V-supply must be assigned to track N+ and COM to N- at the encoder plug. The monitoring for channel 1 will be switched on/off with parameter Ec.42 (in the past Ec.20).

The recognition of encoder breakage triggers an „error! encoder 1“ (value 32), if the voltage between two signal pairs is smaller than 625mV.

3.2.4 Connection of the encoder

3.2.4.1 Encoder cable at terminal strip X3A

- Encoder cable double-shielded and twisted in pairs
- Connect exterior shielding at both ends to PE/GND
- Connect interior shieldings at one side to COM
- Do not connect exterior and interior shielding

Figure 3.2.4.1 Connection of the encoder

Motor encoder plug		Terminal strip X3A	
Name	PIN		
		PIN	Core color
A+	5	1	green
A-	6	2	yellow
B+	8	3	blue
B-	1	4	red
N+	3	5	gray
N-	4	6	pink
15/24V	12	7	brown
COM	10	8	white
GND	-	-	exterior shielding

3.2.5 Encoder channel

KEB encoder cables are corresponding to the following specification:

Signal lines	4 x (2 x 0.14 mm ²)
Supply lines	2 x (0.5 mm ²)
Particularities	trailing capable, oil resistant
Temperature range	constant up to 80 °C
Color	green RAL 6018
Material number	00.F5.0C1-4xxx

3.2.6 Encoder line length

The maximum line length of the connecting cable is 50 m. It is limited by the signal frequency, cable capacity and the line resistance.

Encoder cable length =	$\frac{U - U_{min}}{I_{max} \cdot 2 \cdot R}$
max. encoder current I _{max} :	see encoder description
Supply voltage U:	5,2 V
min. supply voltage U _{min} :	see encoder description
KEB encoder cable resistance R:	0,036 Ω/m at 0,5 mm ²

3.2.7 Tested encoder

The following TTL incremental encoders have been tested by KEB on it application:

Heidenhain ROD 426

However, this does not restrict the use of rotary encoder with same specifications of other manufacturers.

3.3 Channel 2

The description of input X3B is depending on the used encoder interface. It is described in a separate manual.

4. Start-up

After the installation or exchange of an encoder interface some adjustments of the inverter/ servo software have to be done before operation:

- Switch on inverter
- Select application mode
- Select parameter Ec.0 and control whether value „13 incremental encoder input 24V TTL In“ is entered. The displayed value has to be confirmed by „ENTER“ in any case.
- Select Ec.1 and adjust increments per revolution
- Select Ec.42 (Ec.20 upto V2.8) and adjust the encoder breakage recognition dependent on the case of operation.
- If several slaves are connected, deactivate the terminating resistor with Ec.20 Bit 1 (do not switch off at last slave).

5. Error messages

Error messages and their meaning are described in Chapter 9 of the application manual.



KEB Automation KG
Südstraße 38 • D-32683 Barntrop
fon: +49 5263 401-0 • fax: +49 5263 401-116
net: www.keb.de • mail: info@keb.de

KEB Worldwide

KEB Antriebstechnik Austria GmbH
Ritzstraße 8 • A-4614 Marchtrenk
fon: +43 7243 53586-0 • fax: +43 7243 53586-21
net: www.keb.at • mail: info@keb.at

KEB Antriebstechnik
Herenveld 2 • B-9500 Geraadsbergen
fon: +32 5443 7860 • fax: +32 5443 7898
mail: vb.belgien@keb.de

KEB Power Transmission Technology (Shanghai) Co.,Ltd.
No. 435 Qianpu Road, Chedun Town, Songjiang District,
CHN-Shanghai 201611, P.R. China
fon: +86 21 37746688 • fax: +86 21 37746600
net: www.keb.de • mail: info@keb.cn

KEB Antriebstechnik Austria GmbH
Organizační složka
K. Weise 1675/5 • CZ-370 04 České Budějovice
fon: +420 387 699 111 • fax: +420 387 699 119
mail: info.keb@seznam.cz

KEB Antriebstechnik GmbH
Wildbacher Str. 5 • D-08289 Schneeberg
fon: +49 3772 67-0 • fax: +49 3772 67-281
mail: info@keb-drive.de

KEB España
C/ Mitjer, Nave 8 - Pol. Ind. LA MASIA
E-08798 Sant Cugat Sesgarrigues (Barcelona)
fon: +34 93 897 0268 • fax: +34 93 899 2035
mail: vb.espana@keb.de

Société Française KEB
Z.I. de la Croix St. Nicolas • 14, rue Gustave Eiffel
F-94510 LA QUEUE EN BRIE
fon: +33 1 49620101 • fax: +33 1 45767495
net: www.keb.fr • mail: info@keb.fr

KEB (UK) Ltd.
Morris Close, Park Farm Industrial Estate
GB-Wellingborough, NN8 6 XF
fon: +44 1933 402220 • fax: +44 1933 400724
net: www.keb-uk.co.uk • mail: info@keb-uk.co.uk

KEB Italia S.r.l.
Via Newton, 2 • I-20019 Settimo Milanese (Milano)
fon: +39 02 3353531 • fax: +39 02 33500790
net: www.keb.de • mail: kebitalia@keb.it

KEB Japan Ltd.
15-16, 2-Chome, Takanawa Minato-ku
J-Tokyo 108-0074
fon: +81 33 445-8515 • fax: +81 33 445-8215
mail: info@keb.jp

KEB Korea Seoul
Room 1709, 415 Missy 2000
725 Su Seo Dong, Gang Nam Gu
ROK-135-757 Seoul/South Korea
fon: +82 2 6253 6771 • fax: +82 2 6253 6770
mail: vb.korea@keb.de

KEB RUS Ltd.
Lesnaya Str. House 30, Dzerzhinsky (MO)
RUS-140091 Moscow region
fon: +7 495 632 0217 • fax: +7 495 632 0217
net: www.keb.ru • mail: info@keb.ru

KEB Sverige
Box 265 (Bergavägen 19)
S-43093 Hälsö
fon: +46 31 961520 • fax: +46 31 961124
mail: vb.schweden@keb.de

KEB America, Inc.
5100 Valley Industrial Blvd. South
USA-Shakopee, MN 55379
fon: +1 952 224-1400 • fax: +1 952 224-1499
net: www.kebamerica.com • mail: info@kebamerica.com

More and latest addresses at <http://www.keb.de>

© KEB	
Mat.No.	DKF5ZEM-K030
Rev.	1B
Date	10/2016