

KEB

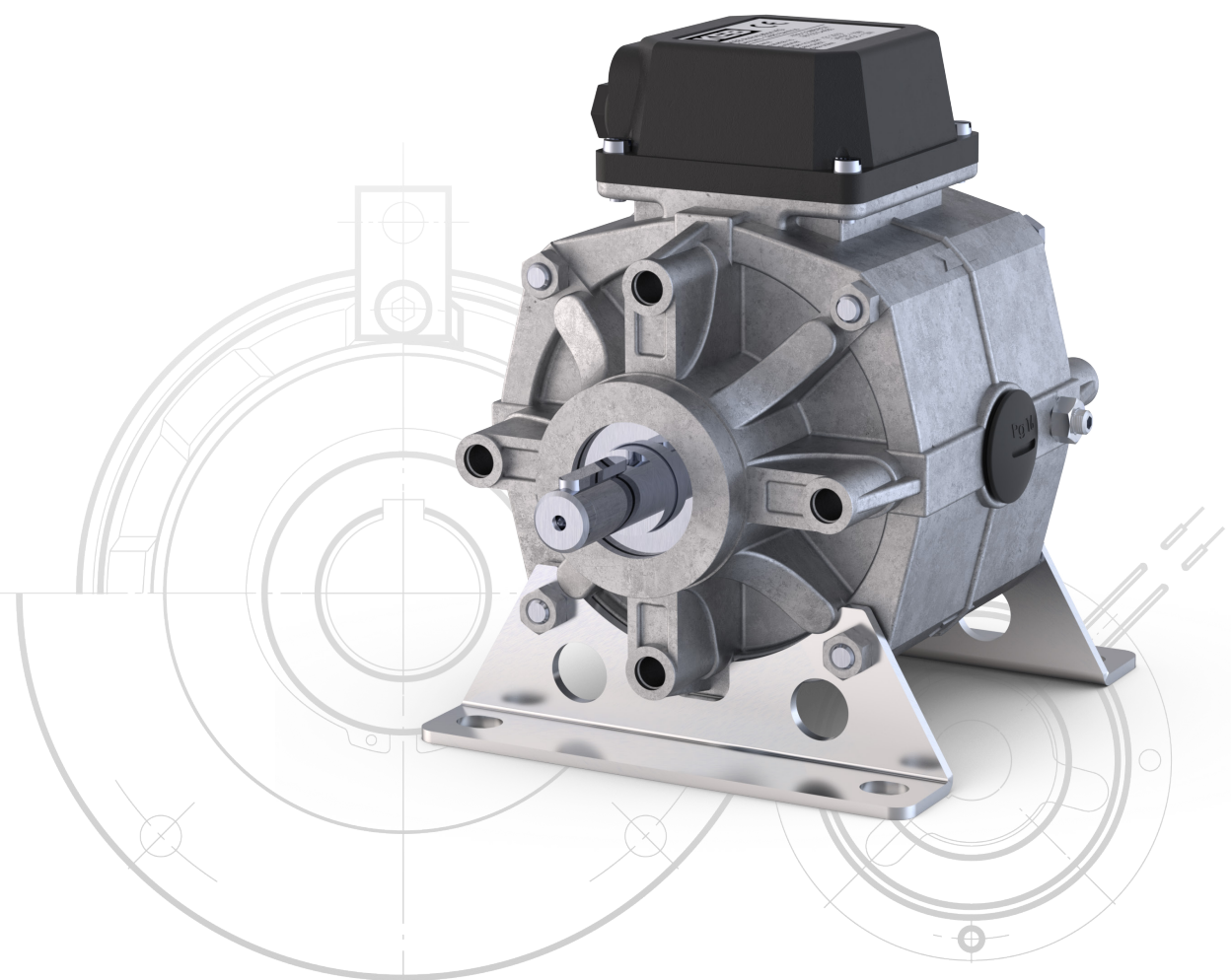

BRAKES & CLUTCHES

COMBIBOX

EN

The KEB logo is displayed in white, bold, sans-serif capital letters on a red rectangular background. The background of the entire page is a low-angle, upward-looking photograph of a complex industrial machine with numerous polished metal pipes, railings, and structural beams, set against a clear blue sky.

KEB AUTOMATION KG

All our efforts are directed towards the development, production and application of electromagnetic technology throughout our extensive range of brakes and clutches.

The functions, **starting, stopping, positioning and safe holding** of moving axes in machines and plant call for reliably designed and safely functioning components.

With our advanced manufacturing techniques we are able to produce high quality, high-grade products, and through our continued investment we now have manufacturing plants worldwide. We have the ability to produce high volume stock parts or ones that are tailored specifically to your requirements.

PROGRAM SCHEDULE

COMBIBOX CLUTCH-BRAKE-COMBINATION TYPE 10 / 09 / 06

with an energised to engage single sided clutch / brake

COMBIBOX 10

with an energised to engage single sided clutch without brake

COMBIBOX 09

with an energised to engage single sides clutch / and energised to disengage single sided permanent magnet brake

COMBIBOX 06

TECHNICAL DATA

COMBIBOX shaft in / shaft out

page 5

COMBIBOX bore in / bore out

page 6

COMBIBOX bore in / shaft out

page 7

COMBIBOX shaft in / bore out

page 8

Moments of inertia, friction work and calculations

page 9

On request we adapt the COMBIBOX to your constructional and electrical requirements.

DESIGN ATTACHMENTS

Input

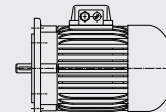
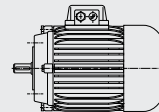
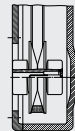

Output

360 / 370

380 / 390

460 / 470

440

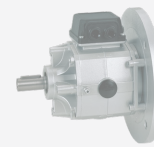
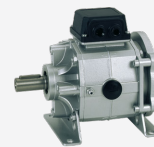
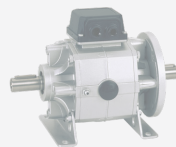
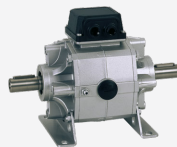

570 / 580

410 / 430

450 / 480

670

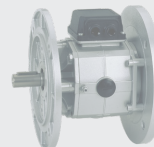
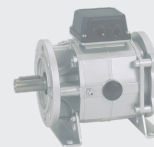
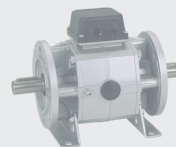
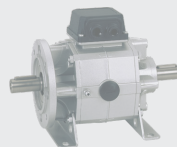
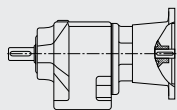

490

500

510

520

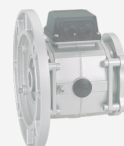
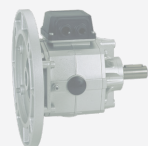
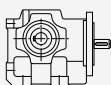

530 / 540

550 / 560

590 / 600

610

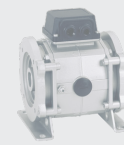
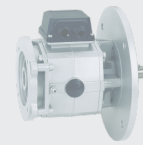
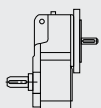

620 / 630

640 / 660

680 / 690

700

800

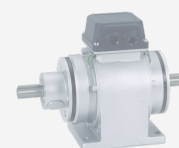
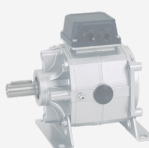

COMBIBOX PROJECT SOLUTIONS

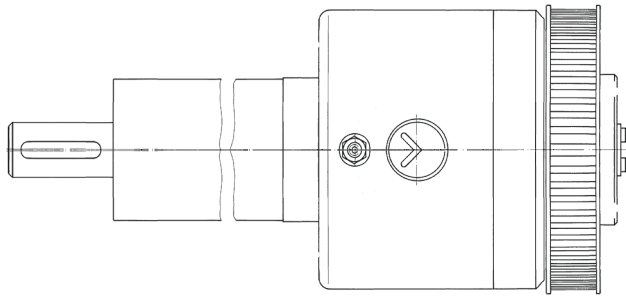

READY FOR INSTALLATION

Compact COMBIBOX with customized housing and sprockets for cycled machine processes.

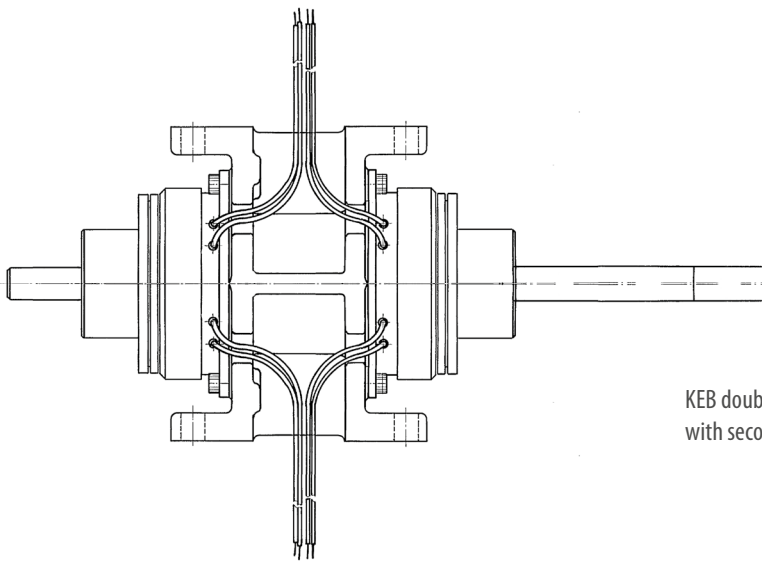

KEB double clutch for engaging and disengaging the motor together with secondary attachments.

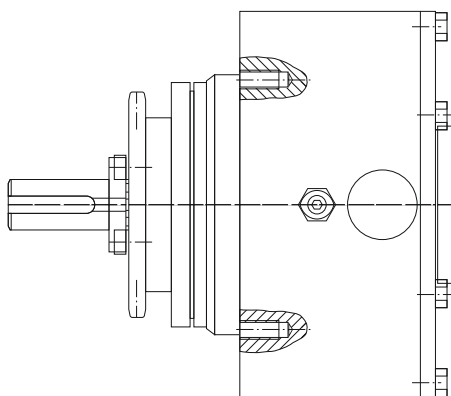

Ready installed KEB COMBIBOX for clutching and breaking a pulley.

The COMBIBOX is a ready to install electromagnetic actuated clutch-brake module in a single housing.

The modular system is designed for a multitude of variants; these covering most of the applications in the field.

The patented adjustment procedure permits an air gap readjustment in it's installed condition. Thus giving a greater lifetime of the wear affected components.

The units designed for Start-Stop-operation considerably reduce the energy consumption due to a continuously running drive.

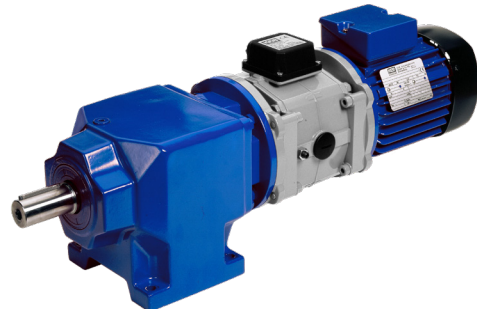

TYPE 10

has an energise to engage single sided brake, this is the most commonly used, permitting high switching frequency and good positioning accuracy. The COMBITRON rapid switch can be used with this variant to achieve expectionally high switching frequencies. The rated torque of both clutch and brake are identical.

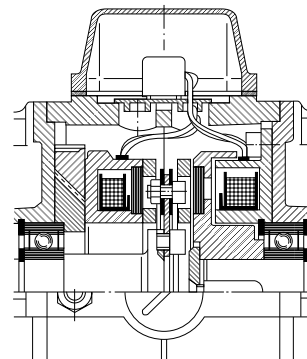

TYPE 09

is the COMBIBOX version without brake, i.e. an electrical clutch in a housing for the use between e.g. motor and gear unit.

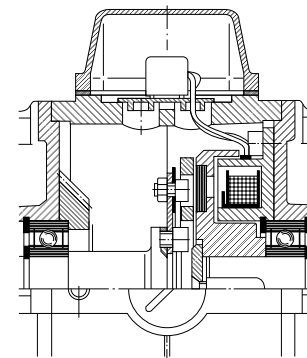

TYPE 06

has an energise to disengage permanent magnet single-side brake. The characteristic of this variant is that the position of the output shaft is kept safe and backlash-free in currentless condition. The rated torque of the brake is slightly lower than that of the clutch.

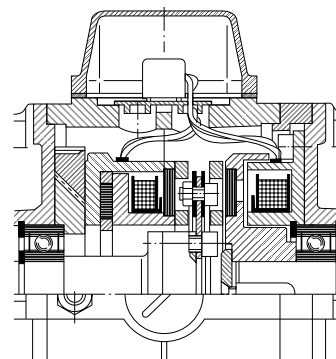

COMBIBOX SHAFT IN / SHAFT OUT

SIZE	a ₃	a ₄	a ₇	b	c	e	f ₂	f ₅	g	h	h ₁	i	k	k ₁	n	s	s ₂	u	Shaft		Weight [kg]
																			d ₁	l	
06	80	100/109	85	115/124	3	72	100	10	103	63	87	18.4	137/146	117/126	18	7	M6	44	11 14	23 30	2.8/2.9
07	105	115/125	110	138/148	3	90	130	10	125	71	94	22.7	160/170	140/150	25	9	M8	50	14 19	30 40	3.9/4.1
08	130	135/147	140	160/172	4	112	160	12	158	90	108	30.6	196/208	172/184	28	9	M8	62	19 24	40 50	7.7/8.7
09	150	155/169	160	180/194	5	137	180	14	185	100	129	34.4	224/238	196/210	30	11	M10	74	24 28	50 60	12.5/15.0
10	185	185/202	195	215/232	6	175	223	18	236	132	154	50.6	286/303	250/267	38	13	M12	95	28	60	22.5/28.0
11	upon request																				

All dimensions in mm keyways according to DIN 6885/1 centerings D according to DIN 332/2 standard voltage 24 V DC VDE 0580, ISO-class „B“

Rated torques type 10 / 09 / 06

		SIZE	06	07	08	09	10	11
T _{2N} ¹⁾ [Nm]	clutch		7	15	30	65	130	250 / -
	brake		7 / 6	15 / 12	30 / 24	65 / 50	130 / 120	250 / -
P ₂₀ [W]	clutch		15	20	28	35	50	68 / -
	brake		12 / 13	16 / 21	21 / 20	28 / 30	38 / 50	50 / -

¹⁾ rated torque after running in process

variations type 06 (marked in red)

PART NO.	feet	input flange B5 (1)	output flange B5 (1)
-----360			
-----370	X		
-----380		X	
-----390	X	X	
-----410		X	X
-----430	X	X	X
-----570			X
-----580	X		X

Design
Type
Size

ORDERING EXAMPLE:

Size  Design

Type
V DC, Ø a₃, Ø d₁ ?

Ordering specification:

- part number
- diameter of input-side flange
- diameter of input-side shaft
- diameter of output-side shaft
- diameter of output-side flange
- operating voltage of COMBIBOX
- flange dimensions on page 11

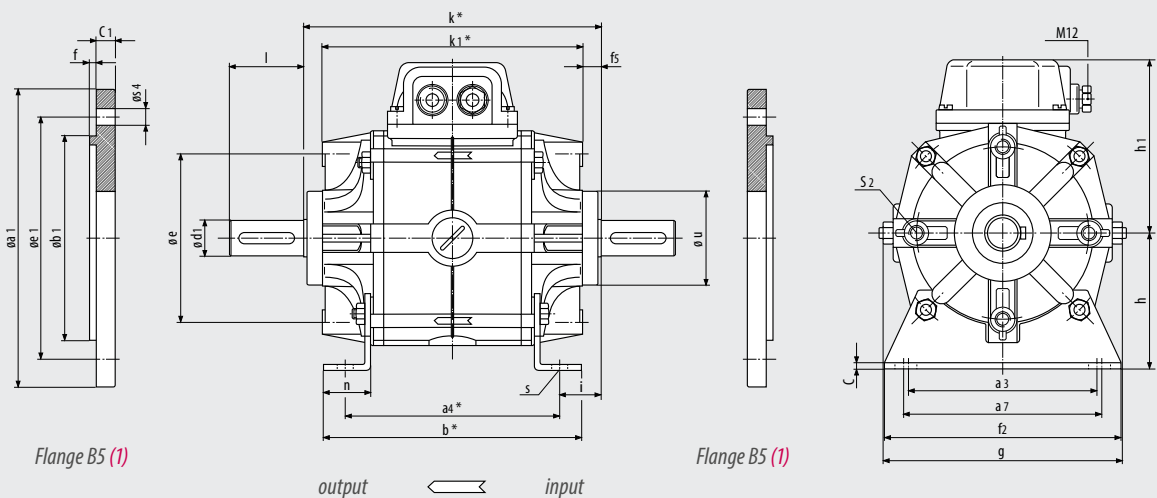

Flange dimensions page 11

COMBIBOX BORE IN / BORE OUT



SIZE	a ₃	a ₄	a ₇	b	c	e	f ₂	f ₅	g	h	h ₁	i	k	k ₁	n	s	s ₂	u	Shaft		Weight [kg]
																			d ₁	l	
06	80	100/109	85	115/124	3	72	100	10	103	63	87	18.4	137/146	117/126	18	7	M6	44	11 14	23 30	2.8/2.9
07	105	115/125	110	138/148	3	90	130	10	125	71	94	22.7	160/170	140/150	25	9	M8	50	14 19	30 40	3.9/4.1
08	130	135/147	140	160/172	4	112	160	12	158	90	108	30.6	196/208	172/184	28	9	M8	62	19 24	40 50	7.7/8.7
09	150	155/169	160	180/194	5	137	180	14	185	100	129	34.4	224/238	196/210	30	11	M10	74	24 28	50 60	12.5/15.0
10	185	185/202	195	215/232	6	175	223	18	236	132	154	50.6	286/303	250/267	38	13	M12	95	28	60	22.5/28.0
11	upon request																				

Alle dimensions in mm keyways according to DIN 6885/1 centerings D according DIN 332/2 standard voltage 24 V DC VDE 0580, ISO-class „B“

SIZE	g	h	h ₁	k ₄	l ₁	l ₂	l ₃	n	s	s ₆	v	α										Weight [kg]
06	103	63	87	101/110	50	57	9	18	7	5.5	30	60										2.7 / 3.1
07	125	71	94	108/118	52	61	9	25	9	6.5	35	60										3.7 / 4.5
08	158	90	108	132/144	63,5	75	11	28	9	8.5	45	64										7.5 / 8.9
09	185	100	129	153/167	74	86	13	30	11	8.5	50	62										12.0 / 14.5
10	236	132	154	175/192	86	102	17	38	13	10.5	70	60										20 / 25.5
11	on request																					

variations type 06 (marked in red) ¹⁾ Nominal torque after running-in

PART NO.	feet	input flange B5 (1)	output flange B5 (1)
-----360			
-----370	X		
-----380		X	
-----390	X	X	
-----410		X	X
-----430	X	X	X
-----570			X
-----580	X		X

Design
Type
Size

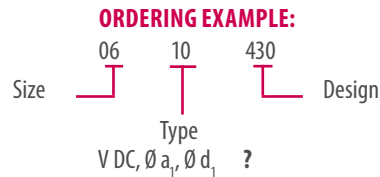

Ordering specification:

- part number
- diameter of input-side flange
- diameter of input-side shaft
- diameter of output-side shaft
- diameter of output-side flange
- operating voltage of COMBIBOX
- flange dimensions on page 11

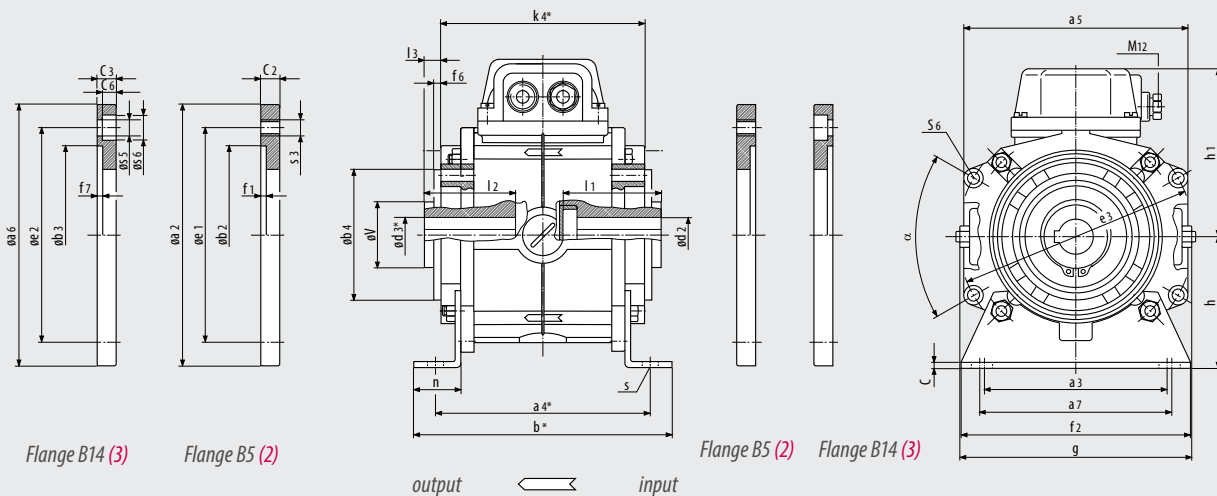

Flange dimensions page 11

COMBIBOX BORE IN / SHAFT OUT

SIZE

	a ₃	a ₄	a ₅	a ₇	b	b ₄ h8	c	d ₂₊₃ G7 _{max}	e	e ₃	f ₂	f ₅	f ₆	g	h
06	80	100/109	104	85	115/124	60	3	15	72	108	100	10	4	103	63
07	105	115/125	123	110	138/148	70	3	24	90	128	130	10	4	125	71
08	130	135/147	155	140	160/172	80	4	28	112	165	160	12	4	158	90
09	150	155/169	178	160	180/194	95	5	35	137	190	180	14	5	185	100
10	185	185/202	229	195	215/232	110	6	42	175	242	223	18	5	236	132
11															upon request

Alle dimensions in mm keyways according to DIN 6885/1 centerings D according DIN 332/2 standard voltage 24 V DC VDE 0580, ISO-class „B“ variations type 06 (marked in red) ¹⁾ Nominal

Rated torques type 10 / 09 / 06

	SIZE	06	07	08	09	10	11
M _{2N} ¹⁾ [Nm]	Clutch	7	15	30	65	130	250 / -
	Brake	7 / 6	15 / 12	30 / 24	65 / 50	130 / 120	250 / -
P ₂₀ [W]	Clutch	15	20	28	35	50	68 / -
	Brake	12 / 13	16 / 21	21 / 20	28 / 30	38 / 50	50 / -

variations type 06 (marked in red) ¹⁾ rated torque after running in process

PART NO.

	feet	input flange		outout flange
		B5 (2)	B14 (3)	B5 (1)
-----440		X		
-----450			X	X
-----460			X	
-----470	X		X	
-----480	X		X	X
-----640				
-----660	X			
-----670		X		X

Design
Type
Size

ORDERING EXAMPLE:

Size 06 10 450 Design
Type
V DC, $\varnothing a_e$, $\varnothing a_r$, $\varnothing d_i$?

Ordering specification:

- part number
- diameter of input-side flange
- diameter of input-side bore
- diameter of output-side bore
- diameter of output-side flange
- operating voltage of COMBIBOX
- flange dimensions on page 11

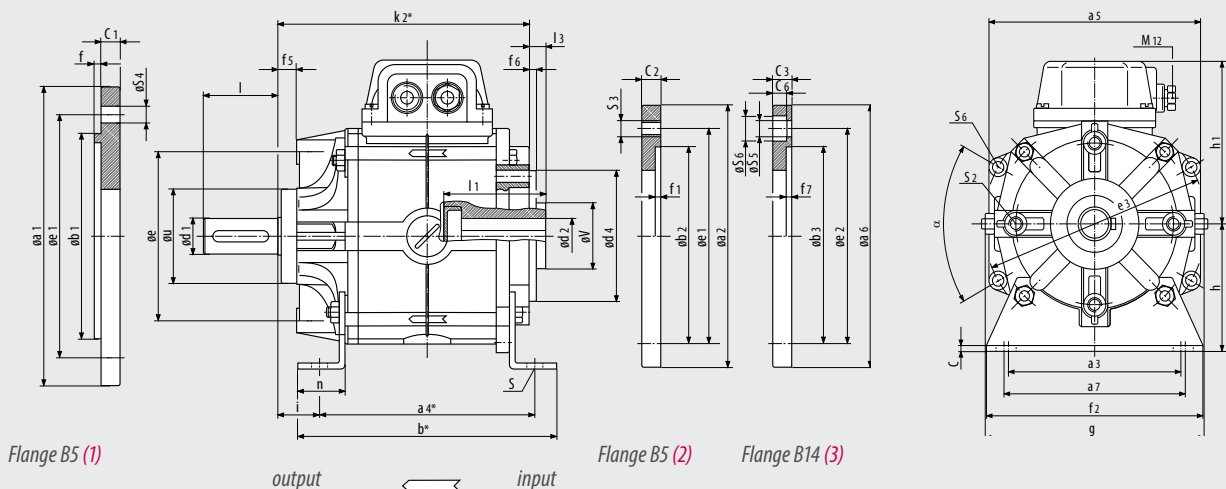

Flange dimensions page 11

COMBIBOX SHAFT OUT / BORE IN



	h_1	i	k_2	l_1	l_3	n	s	s_2	s_6	u h8	v	α	Preferential-bore	Shaft		Weight [kg]
													d_2 und d_3	d_1 k6	l	
	87	18.4	119/128	50	9	18	7	M6	5.5	44	30	60	11 oder 14	11 14	23 30	2.8/3.1
	94	22.7	134/144	52	9	25	9	M8	6.5	50	35	60	14 oder 19	14 19	30 40	3.9/4.5
	108	30.6	164/176	63,5	11	28	9	M8	8.5	62	45	64	19 oder 24	19 24	40 50	7.7/8.9
	129	34.4	189/203	74	13	30	11	M10	8.5	74	50	62	24 oder 28	24 28	50 60	12.5/14.5
	154	50.6	231/248	86	17	38	13	M12	10.5	95	70	60	28	28	60	22.5/26.0

¹⁾ Nominal torque after running-in

PART NO.	feet	input flange B5 (1)	output flange B5 (2) B14 (3)	
-----490			X	X
-----500		X	X	
-----530				X
-----540	X			X
-----550		X		X
-----560	X	X		X
-----620				
-----630	X			

Design
Type
Size

ORDERING EXAMPLE:

Size $\frac{06}{10}$ $\frac{10}{500}$ Design
 Typ
 V DC, $\emptyset a_1, \emptyset d_1, \emptyset a_2, \emptyset d_3$?

Ordering specification:

- part number
- diameter of input-side flange
- diameter of input-side bore
- diameter of output-side shaft
- diameter of output-side flange
- operating voltage of COMBIBOX
- flange dimensions on page 11

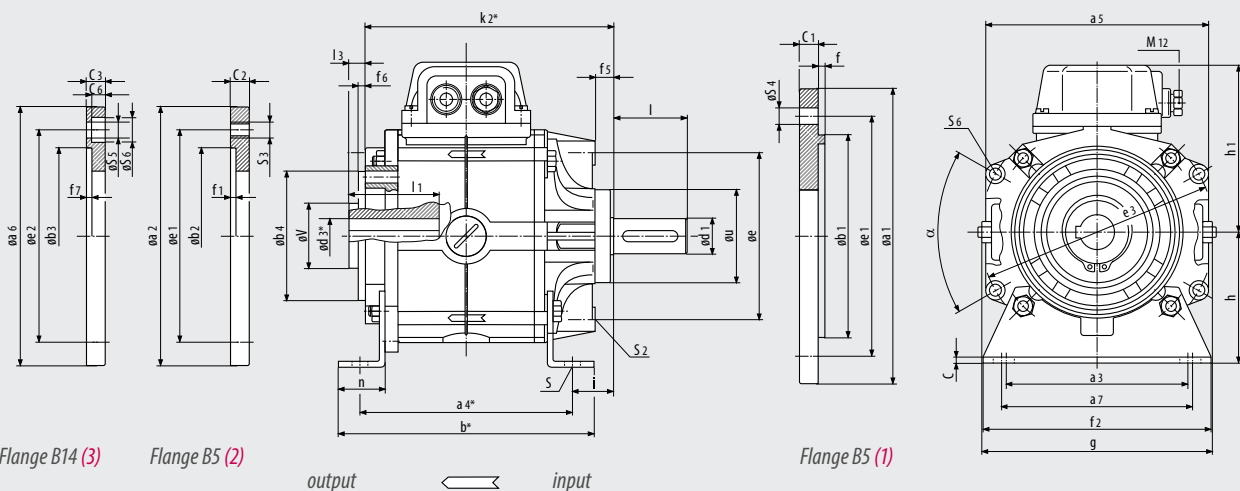

Flange B14 (3) Flange B5 (2)
 Flange dimensions page 11

Flange B5 (1)

COMBIBOX TECHNICAL DATA

COMBIBOX 06 / 09 / 10				06	07	08	09	10	11
Size	Type	Type							
$T_{2N}^{2)}$	Clutch	06/09/10	[Nm]	7	15	30	65	130	250
	Brake	10		7	15	30	65	130	250
		06			6	12	24	50	120
P_{20}	Clutch	06/09/10	[W]	15	20	28	35	50	68
	Brake	10		12	16	21	28	38	50
		06			13	21	20	30	50
$J^{1)}$	Rotor	06/09/10	$[10^{-4}kgm^2]$	1.07	2.98	7.78	23.29	67.4	220
	Armature	06/10		0.84	2.62	8.59	23.08	91.07	330
	Armature	09		0.80	1.2	4.8	12.61	54.3	190
W_{Rmax}		06/09/10	$[10^3J]$	1.9	3.1	4.8	7.5	12.5	20.0
$W_{R0.1mm}$	Clutch	06/09/10	$[10^6J]$	9.5	16.3	25.3	40.9	66.6	104
	Brake	06/10		9.5	16.3	25.3	40.9	66.6	104
$P_{Rmax.}$	Clutch	06/09/10	[J/s]	81	114	161	228	323	458
	Brake	06/10		59	80	114	164	236	339
X		06/09/10	[mm]	0.2	0.3	0.35	0.35	0.4	0.5
X_n		06/09/10	[mm]	0.4	0.6	0.7	0.7	0.8	1.0
n_{max}		06/09/10	[rpm]	3,000	3,000	3,000	3,000	3,000	3,000

SWITCHING TIMES		Type 09/10 rated voltage [ms]				Type 06 rated voltage [ms]			
Clutch		t_{11}	t_1	t_2	t_1	t_{11}	t_1	t_2	t_1
Brake		t_2	t_1	t_{11}	t_1	t_{11}	t_1	t_2	t_1
Size	06	18	55	15	45	20	50	10	45
	07	25	95	20	60	25	85	14	50
	08	40	125	30	110	40	100	22	68
	09	50	200	40	160	50	200	30	150
	10	60	250	45	220	85	250	40	180
	11	100	300	80	260				

$J^{1)}$	= moment of inertia	[kgm ²]	t_1	= Engaging time, time until 0.9 T_{2N} is reached	[ms]
$T_{2N}^{2)}$	= rated torque after running in process	[Nm]	t_{11}	= Engaging delay time, time until the armature is attracted	[ms]
P_R	= permissible friction per second	[J/s]	t_2	= Release time, time until the armature is attracted to the opposing side.	[ms]
P_{20}	= power input at 20 °C	[W]			
W_R	= friction	[J]			
$W_{R0.1}$	= friction work until an abrasion of 0,1 mm is reached	[J]			
X	= rated air gap	[mm]			
X_n	= clearance at which a readjustment is recommende	[mm]			

- Sum of the moment of inertia reduced to the speed of the COMBIBOX plus the moment of inertia of the COMBIBOX parts to be accelerated or decelerated (J).
- The rated torques listed are safely attained after a run-in phase at 100 rpm. In new condition and for substantially higher speeds the torques are possibly lower.

POWER SUPPLY

COMBIBOX requires d.c. voltage for actuation. The rated voltage of the magnets is 24 V DC standard. For operation with rectifiers the magnets are available in other voltages on specification. The permanent-magnet brake installed in type 06 requires a smoothed supply voltage. To ensure a safe function in case of large temperature fluctuations, we recommend the supply of the coil with constant current.

COMBIBOX FLANGE DIMENSIONS

SIZE	IEC Ø ¹⁾	a1 (1)	a2 (2)	a6 (3)	b1 (1) h8	b2 (2) +0.3 +0.2	b3 (3) H8	c1 (1)	c2 (2)	c3 (3)	c6 (3)
06	90	90	120	120	60	60	60	10	10	10	5.5
	105	105	120	120	70	70	70	10	10	10	6.5
	120	120	120	120	80	80	80	10	10	10	6.5
	140	140	140	140	95	95	95	10	10	12	8.0
	160	160	160	160	110	110	110	10	12	12	8.0
07	105	110	120	120	70	70	70	10	10	10	6.5
	120	120	120	120	80	80	80	10	10	10	6.5
	140	140	140	140	95	95	95	10	10	10	6.0
	160	160	160		110	110		10	12		6.0
	200	200	200		130	130		10	14		8.0
08	120	130	-	160	80		80	12		12	6.5
	140	140	160	160	95	95	95	12	12	12	6.0
	160	160	160	160	110	110	110	12	12	12	6.0
	200	200	200	200	130	130	130	12	14	14	7.0
	250	250	250	-	180	180		12	14		
09	140	160	160	160	95	95	95	14	14	14	9.0
	160	160	160	160	110	110	110	14	14	14	9.0
	200	200	200	200	130	130	130	14	14	14	
	250	250	250	250	180	180	180	14	14	14	
10	160	-	200	200		110	110		18	18	9.0
	200	210	200	200	130	130	130	18	18	18	8.0
	250	250	250		180	180		18	18		
	300	300	300		230	230		18	18		
	350	350			250			20			
11	250	250	268		180	180		20	25		
	300	300	300		230	230		20	25		
	350	350	350		250	250		20	25		
SIZE	IEC Ø ¹⁾	e1 (1+2)	e2 (3)	f (1)	f1 (2)	f7 (3)	s3 (2)	s4 (1)	s5(3)	s6 (3)	Weight (1/2/3) [kg]
06	90	75	75	2.5	3	3	M5	5.5	5.5	10	0.16
	105	85	85	2.5	3.5	3	M6	7.0	6.5	11	0.17
	120	100	100	3	3.5	3.5	M6	6.5	6.5	11	0.2
	140	115	115	3	3.5	3.5	M8	9	8.5	14	0.28
	160	130	130	3.5	4	4	M8	9	8.5	14	0.45
07	105	85	85	2.5	3.5	3	M6	M6	6.5	11	0.21
	120	100	100	3	3.5	3.5	M6	6.5	6.5	11	0.22
	140	115	115	3	3.5	3.5	M8	9	9	14	0.3
	160	130		3.5	4		M8	9		14	0.33
	200	165		3.5	4		M10	11		18	0.55
08	120	100	100	3		3.5		7	6.5	11	0.45
	140	115	115	3	3.5	3.5	M8	9	9	14	0.48
	160	130	130	3.5	4	4	M8	9	9	14	0.5
	200	165	165	3.5	4	4.5	M10	11	14	18	0.8
	250	215	215	4	4.5		M12	14			1.4
09	140	115	115	3		3.5		9	9	15	0.5
	160	130	130	3.5	4	4	M8	9	9	15	0.55
	200	165	165	3.5	4	4	M10	11	11		0.63
	250	215	215	4	4.5	4.5	M12	14	14		0.95
10	200	165	165	4	4.5	4	M10	11	11	18	1.1
	250	215		4	4.5		M12	14			1.2
	300	265		4	5		M12	14			1.25
	350	300		5				18			6.5
11	250	215		4	4.5		M12	14			
	300	265		4	4.5		M12	14			
	350	300		5	5.5		M16	18			

¹⁾ according DIN IEC 34 standard flange



KEB WORLDWIDE

Austria | KEB Automation GmbH
Ritzstraße 8 4614 Marchtrenk Austria
Phone: +43 7243 53586-0 Fax: +43 7243 53586-21
E-Mail: info@keb.at Web: keb-automation.com

Benelux | KEB Automation KG
Boulevard Paepsem 20 – Paepsem laan 20 1070 Anderlecht Belgium
Phone: +32 2 447 8580
E-Mail: info.benelux@keb.de Web: keb-automation.com

Czech Republic | KEB Automation s.r.o.
Videnska 188/119d 61900 Brno Czech Republic
Phone: +420 544 212 008
E-Mail: info@keb.cz Web: keb-automation.com

France | Société Française KEB SASU
Z.I. de la Croix St. Nicolas 14, rue Gustave Eiffel
94510 La Queue en Brie France
Phone: +33 149620101 Fax: +33 145767495
E-Mail: info@keb.fr Web: keb-automation.com

Germany | Geared Motors
KEB Antriebstechnik GmbH
Wildbacher Straße 5 08289 Schneeberg Germany
Phone: +49 3772 67-0 Fax +49 3772 67-281
E-Mail: info@keb-drive.de Web: keb-automation.com

Italy | KEB Italia S.r.l. Unipersonale
Via Newton, 2 20019 Settimo Milanese (Milano) Italy
Phone: +39 02 3353531 Fax: +39 02 33500790
E-Mail: info@keb.it Web: https://blog.keb.it

Japan | KEB Japan Ltd.
711-103 Fukudayama, Fukuda,
Shinjo-shi Yamagata 996-0053 Japan
Phone: +81 233 292800 Fax: +81 233 292802
E-Mail: info@keb.jp Web: keb.jp

P. R. China | KEB Power Transmission Technology (Shanghai) Co. Ltd.
No. 435 QianPu Road Chedun Town Songjiang District
201611 Shanghai P. R. China
Phone: +86 21 37746688 Fax: +86 21 37746600
E-Mail: info@keb.cn Web: keb.cn

Poland | KEB Automation KG
Phone: +48 604 077 727
E-Mail: roman.trinczek@keb.de Web: keb-automation.com

Republic of Korea | KEB Automation KG
Deoksan-Besttel 1132 ho Sangnam-ro 37
Seongsan-gu Changwon-si Gyeongsangnam-do Republic of Korea
Phone: +82 55 601 5505 Fax: +82 55 601 5506
E-Mail: vb.korea@keb.de Web: keb-automation.com

Spain | KEB Automation KG
c / Mitjer, Nave 8 - Pol. Ind. LA MASIA
08798 Sant Cugat Sesgarrigues (Barcelona) Spain
Phone: +34 93 8970268
E-Mail: vb.espana@keb.de Web: keb-automation.com

Switzerland | KEB Automation AG
Barzloostrasse 1 8330 Pfaeffikon/ZH Switzerland
Phone: +41 43 2886060
E-Mail: info@keb.ch Web: keb-automation.com

United Kingdom | KEB (UK) Ltd.
5 Morris Close Park Farm Industrial Estate
Wellingborough, Northants, NN8 6XF United Kingdom
Phone: +44 1933 402220 Fax: +44 1933 400724
E-Mail: info@keb.co.uk Web: keb-automation.com

United States | KEB America, Inc.
5100 Valley Industrial Blvd. South
Shakopee, MN 55379 United States
Phone: +1 952 2241400 Fax: +1 952 2241499
E-Mail: info@kebameric.com Web: kebameric.com



KEB PARTNERS WORLDWIDE

www.keb-automation.com/contact

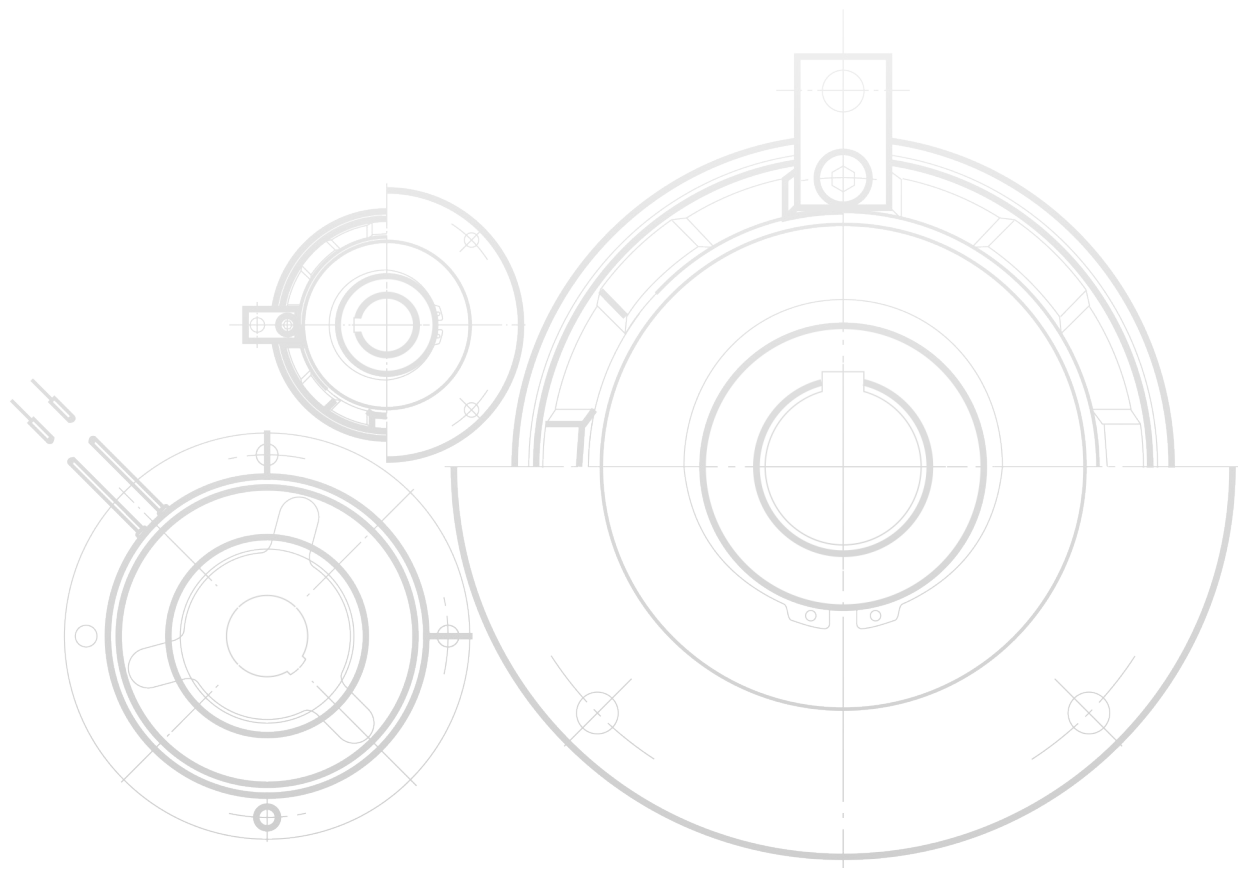

Automation with Drive

keb-automation.com

KEB Automation KG Südstrasse 38 32683 Barntrup Germany Tel. +49 5263 401-0 E-Mail: info@keb.de

© KEB 0000000-5COMBIBOX 09.2024 Subject to technical alterations!