



DYNAMIC LINE III

INSTRUCTIONS FOR USE | **SERVO MOTORS SMH**
SIZE 01...F3

Translation of original manual
Document 20092083 EN 09





Preface

The hardware and software described in this document are products of KEB. The information contained in this document is valid at the time of publishing. KEB reserves the right to update this document in response to misprints, mistakes or technical changes.

Signal words and symbols

Certain procedures within this document can cause safety hazards during the installation or operation of the device. Refer to the safety warnings in this document when performing these procedures. Safety signs are also located on the device where applicable. A safety warning is marked by one of the following warning signs:

 DANGER	Dangerous situation, which will cause death or serious injury if this safety warning is ignored.
 WARNING	Dangerous situation, which may cause death or serious injury if this safety warning is ignored.
 CAUTION	Dangerous situation, which may cause minor injury if this safety warning is ignored.
NOTICE	Situation, which can cause damage to property if this safety warning is ignored.

RESTRICTION

Used when the following statements depend on certain conditions or are only valid for certain ranges of values.



Used for informational messages or recommended procedures.

More symbols

- ▶ This arrow starts an action step.
- / - Enumerations are marked with dots or indents.
- => Cross reference to another chapter or another page.



Note to further documentation.
www.keb.de/service/downloads



Laws and guidelines

KEB Automation KG confirms with the EC declaration of conformity and the CE mark on the device nameplate that it complies with the essential safety requirements.

The EC declaration of conformity can be downloaded on demand via our website. Further information is provided in chapter "Certification".

Warranty and liability

The warranty and liability on design, material or workmanship for the acquired device is given in the general sales conditions.



Here you will find our general sales conditions.
www.keb.de/terms-and-conditions



Further agreements or specifications require a written confirmation.

Support

Although multiple applications are referenced, not every case has been taking into account. If you require further information or if problems occur which are not referenced in the documentation, you can request the necessary information via the local KEB agency.

The use of our units in the target products is outside of our control and therefore lies exclusively in the area of responsibility of the customer.

The information contained in the technical documentation, as well as any user-specific advice in spoken and written and through tests, are made to best of our knowledge and information about the intended use. However, they are regarded as being only informal and changes are expressly reserved, in particular due to technical changes. This also applies to any violation of industrial property rights of a third-party. Selection of our units in view of their suitability for the intended use must be done generally by the user.

Tests can only be done within the intended end use of the product (application) by the customer. They must be repeated, even if only parts of hardware, software or the unit adjustment are modified.

Copyright

The customer may use the instructions for use as well as further documents or parts from it for internal purposes. Copyrights are with KEB and remain valid in its entirety.

This KEB product or parts thereof may contain third-party software, including free and/or open source software. If applicable, the license terms of this software are contained in the instructions for use. The instructions for use are already available to you, can be downloaded free of charge from the KEB website or can be requested from the respective KEB contact person.

Other wordmarks or/and logos are trademarks (™) or registered trademarks (®) of their respective owners.

Table of Contents

Preface	3
Signal words and symbols	3
More symbols.....	3
Laws and guidelines.....	4
Warranty and liability.....	4
Support	4
Copyright.....	4
Table of Contents	5
List of Figures	7
List of Tables	8
Glossary	9
Standards for asynchronous and synchronous motors	10
1 Basic Safety Instructions	12
1.1 Target group.....	12
1.2 Transport, storage and proper use	12
1.3 Installation.....	13
1.4 Connection instructions	14
1.4.1 EMC-compatible installation.....	14
1.5 Start-up and operation	15
1.6 Maintenance.....	15
1.7 Repair	16
1.8 Disposal.....	16
2 Product Description	17
2.1 Specified application.....	17
2.1.1 Residual risks	17
2.2 Unintended use.....	17
2.3 Type code	18
2.4 General speed-torque characteristic	19
2.5 General project design.....	19
2.5.1 Selection of the servo motor.....	19
2.5.2 Selection of the servo controller	20
2.5.3 Output component	20
2.5.4 Pretension factor	20
2.6 Safety function.....	20
2.7 Construction and definition.....	21
2.7.1 Drive end and direction of rotation	21
2.7.2 Winding and insulation system.....	22
2.7.3 Holding brake (optional)	22
2.7.4 Speed and shaft position measuring system.....	23
2.7.5 Temperature monitoring	24

3	Operating Conditions	26
3.1	Product features of the DL3 servo motors	26
3.2	Test flange for thermal determinations	27
3.3	Coolant temperature at different site altitudes	27
3.4	Degree of protection of servo motors	28
3.4.1	Usage of connector systems	28
4	Connection	29
4.1	Rotatability of flange sockets	29
4.2	Connectors	30
4.3	Motor connection	31
4.4	Encoder connection	32
4.4.1	Resolver terminal assignment	32
4.4.2	Hiperface terminal assignment	32
5	Technical Data	33
5.1	Permissible axial and radial forces	33
5.2	Shaft end	34
5.3	Technical data servo motors 0xSMHFx-xxxx	35
5.3.1	Technical data of the holding brake 02P1320-0407	36
5.4	Technical data servo motors AxSMHFx-xxxx	38
5.4.1	Technical data of the holding brake 03P1320-1417	39
5.5	Technical data servo motors BxSMHFx-xxxx	41
5.5.1	Technical data of the holding brake 03P1320-1177 and 05P1320-1077	42
5.6	Technical data servo motors CxSMHFx-xxxx	44
5.6.1	Technical data of the holding brake 06P1320-1247	45
5.7	Technical data servo motors DxSMHFx-xxxx	47
5.7.1	Technical data of the holding brake 06P1320-1247 and 06P1320-1257	48
5.8	Technical data servo motors ExSMHFx-xxxx	50
5.8.1	Technical data of the holding brake 07P1320-1147 and 08P1320-1097	51
5.9	Technical data servo motors FxSMHFx-xxxx	53
5.9.1	Technical data of the holding brake 09P1320-0617	54
6	Certification	56
6.1	Certification	56
6.1.1	CE-Marking	56
6.1.2	UL certification	56
6.2	Further information and documentation	56

List of Figures

Figure 1:	General speed-torque characteristic.....	19
Figure 2:	Example figure of an engine	21
Figure 3:	Varistor protective wiring.....	23
Figure 4:	I / I ₀ to t characteristics	25
Figure 5:	Top view of a DL3 motor	29
Figure 6:	Connectors with a view to the connection pins at the motor.....	30
Figure 7:	Motor connector terminal assignment with a view to the connection pins at the motor ...	31
Figure 8:	Resolver terminal assignment.....	32
Figure 9:	Hiperface terminal assignment	32
Figure 10:	Axial and radial forces.....	34
Figure 11:	Shaft end.....	34
Figure 12:	Dimensions servo motors 0xSMHFx-xxxx	36
Figure 13:	Speed-torque characteristics for 0xSMHFx-xxxx.....	37
Figure 14:	Dimensions servo motors AxSMHFx-xxxx	39
Figure 15:	Speed-/torque characteristics for AxSMHFx-xxxx.....	40
Figure 16:	Dimensions servo motors BxSMHFx-xxxx.....	42
Figure 17:	Speed-/torque characteristics for BxSMHFx-xxxx	43
Figure 18:	Dimensions servo motors CxSMHFx-xxxx.....	45
Figure 19:	Speed/torque characteristics for CxSMHFx-xxxx	46
Figure 20:	Dimensions servo motors DxSMHFx-xxxx.....	48
Figure 21:	Speed-/torque characteristics for DxSMHFx-xxxx	49
Figure 22:	Dimensions servo motors ExSMHFx-xxxx.....	51
Figure 23:	Speed-/torque characteristics for ExSMHFx-xxxx	52
Figure 24:	Dimensions servo motors FxSMHFx-xxxx.....	54
Figure 25:	Speed/torque characteristics for FxSMHFx-xxxx.....	55

List of Tables

Table 1:	Type code	18
Table 2:	Product features.....	26
Table 3:	Dimensions and material of the test flange.....	27
Table 4:	Coolant temperature	27
Table 5:	IP Degree of protection of servo motors	28
Table 6:	Permissible axial and radial forces	33
Table 7:	Technical data servo motors 0xSMHFx-xxxx.....	35
Table 8:	Rated voltage-dependent technical data servo motors 0xSMHFx-xxxx	35
Table 9:	Technical data of the holding brake 02P1320-0407.....	36
Table 10:	Technical data servo motors AxSMHFx-xxxx.....	38
Table 11:	Rated voltage-dependent technical data servo motors AxSMHFx-xxxx	38
Table 12:	Technical data of the holding brake 03P1320-1417.....	39
Table 13:	Technical data servo motors BxSMHFx-xxxx.....	41
Table 14:	Rated voltage-dependent technical data servo motors BxSMHFx-xxxx.....	41
Table 15:	Technical data of the holding brake 03P1320-1177 and 05P1320-1077	42
Table 16:	Technical data servo motors CxSMHFx-xxxx	44
Table 17:	Rated voltage-dependent technical data servo motors CxSMHFx-xxxx.....	44
Table 18:	Technical data of the holding brake 06P1320-1247.....	45
Table 19:	Technical data servo motors DxSMHFx-xxxx	47
Table 20:	Rated voltage-dependent technical data servo motors DxSMHFx-xxxx.....	47
Table 21:	Technical data of the holding brake 06P1320-1247 and 06P1320-1257	48
Table 22:	Technical data servo motors ExSMHFx-xxxx.....	50
Table 23:	Rated voltage-dependent technical data servo motors ExSMHFx-xxxx.....	50
Table 24:	Technical data of the holding brake 07P1320-1147 and 08P1320-1097	51
Table 25:	Technical data servo motors FxSMHFx-xxxx.....	53
Table 26:	Rated voltage-dependent technical data servo motors FxSMHFx-xxxx	53
Table 27:	Technical data of the holding brake 09P1320-0617.....	54

Glossary

0V	Earth-potential-free common point	MCM	American unit for large wire cross sections
1ph	1-phase mains	Modulation	Means in drive technology that the power semiconductors are controlled
3ph	3-phase mains	MTTF	Mean service life to failure
AC	AC current or voltage	NN	Sea level
Application	The application is the intended use of the KEB product.	PE	Protective earth
ASCL	Asynchronous sensorless closed loop	PELV	Protective Extra Low Voltage
Auto motor ident.	Automatically motor identification; calibration of resistance and inductance	PFD	Term used in the safety technology (EN 61508-1...7) for the size of error probability
AWG	American wire gauge	PFH	Term used in the safety technology (EN 61508-1...7) for the size of error probability per hour
B2B	Business-to-business	PLC	Programmable logic controller
BiSS	Open source real-time interface for sensors and actuators (DIN 5008)	PT100	Temperature sensor with R0=100Ω
COMBIVERT	KEB drive converters	PT1000	Temperature sensor with R0=1000Ω
COMBIVIS	KEB start-up and parameterizing software	PTC	PTC-resistor for temperature detection
Customer	The customer has purchased a KEB product from KEB and integrates the KEB product into his product (customer product) or resells the KEB product (dealer)	PWM	Pulse width modulation
DC	DC current or voltage	RJ45	Modular connector with 8 lines
DIN	German Institut for standardization	SCL	Synchronous sensorless closed loop
EMC	Electromagnetic compatibility	SELV	Safety Extra Low Voltage (<60V)
Emergency stop	Shutdown of a drive in emergency case (not de-energized)	SS1	Safety function „Safe stop 1“ in accordance with IEC 61800-5-2
Emergency switching off	Switching off the voltage supply in emergency case	SSI	Synchronous serial interface for encoder
EN	European standard	STO	Safety function „Safe Torque Off“ in accordance with IEC 61800-5-2
End customer	The end customer is the user of the customer product.	TTL	Incremental signal with an output voltage up to 5V
FE	Functional earth	VARAN	Real-time Ethernet bus system
FU	Drive converter		
GND	Reference potential, ground		
Hiperface	Bidirectional encoder interface of the company Sick-Stegmann		
HTL	Incremental signal with an output voltage (up to 30V) -> TTL		
IEC	International standard		
IP xx	Degree of protection (xx for level)		
KEB product	The KEB product is subject of this manual.		
KTY	Silicium temperature sensor (polarized)		
Manufacturer	The manufacturer is KEB, unless otherwise specified (e.g. as manufacturer of machines, engines, vehicles or adhesives).		

Standards for asynchronous and synchronous motors

DGUV regulation 3	Electrical installations and equipment
DIN 46228-1	Tubular end-sleeves without plastic sleeve
DIN 46228-4	Tubular end-sleeves with plastic sleeve
DIN IEC 60364-5-54	Low-voltage electrical installations - Part 5-54: Selection and erection of electrical equipment - Earthing arrangements, protective conductors and protective bonding conductors
EN 60204-1	Safety of machinery - Electrical equipment of machines - Part 1: General requirements (IEC 44/709/CDV)
EN 60439-1	Low-voltage switchgear and controlgear assemblies - Part 1: Type-tested and partially type-tested assemblies (IEC 60439-1)
EN 60529	Degrees of protection provided by enclosures (IP Code) (IEC 60529)
EN 60664-1	Insulation coordination for equipment within low-voltage systems - Part 1: Principles, requirements and tests (IEC 60664-1)
EN 60721-3-1	Classification of environmental conditions - Part 3: Classification of groups of environmental parameters and their severities - Section 1: Storage (IEC 104/648/CD)
EN 60721-3-2	Classification of environmental conditions - Part 3: Classification of groups of environmental parameters and their severities - Section 2: Transportation and handling (IEC 104/670/CD)
EN 60721-3-3	Classification of environmental conditions - Part 3: Classification of groups of environmental parameters and their severities; section 3: Stationary use at weatherprotected locations (IEC 60721-3-3)
EN 61800-2	Adjustable speed electrical power drive systems - Part 2: General requirements - Rating specifications for low voltage adjustable speed a.c. power drive systems (IEC 61800-2)
EN 61800-3	Adjustable speed electrical power drive systems - Part 3: EMC requirements and specific test methods (IEC 22G/297A/CD)
EN 61800-5-1	Adjustable speed electrical power drive systems - Part 5-1: Safety requirements - Electrical, thermal and energy (IEC 61800-5-1)
UL 61800-5-1	American version of the EN 61800-5-1 with „National Deviations“
EN 60034-1	Rotating electrical machines - Part 1: Rating and performance (IEC 2/1768/CD)
EN 60034-2-3	Rotating electrical machines - Part 2-3: Specific test methods for determining losses and efficiency of converter-fed AC motors (IEC 2/1841/CD)
EN 60034-5	Rotating electrical machines - Part 5: Degrees of protection provided by integral design of rotating electrical machines (IP code) - Classification (IEC 60034-5)
EN 60034-6	Rotating electrical machines - Part 6: Methods of cooling (IC-Code) (IEC 60034-6)
EN 60034-7	Rotating electrical machines - Part 7: Classification of types of construction, mounting arrangements and terminal box position (IM code) (IEC 60034-7)
EN 60034-8	Rotating electrical machines - Part 8: Terminal markings and direction of rotation (IEC 60034-8)
EN 60034-9	Rotating electrical machines - Part 9: Noise limits (IEC 60034-9)
EN 60034-11	Rotating electrical machines - Part 11: Thermal protection (IEC 60034-11)
EN 60034-14	Rotating electrical machines - Part 14: Mechanical vibration of certain machines with shaft heights 56 mm and higher - Measurement, evaluation and limits of vibration severity (IEC 60034-14)
IEC/TS 60034-17	Rotating electrical machines - Part 17: Cage induction motors when fed from converters - Application guide (IEC/TS 60034-17)
EN 60034-18-41	Rotating electrical machines - Part 18-41: Partial discharge free electrical

	insulation systems (Type I) used in rotating electrical machines fed from voltage converters - Qualification and quality control tests (IEC 60034-18-41)
EN 60034-18-42	Rotating electrical machines - Part 18-42: Partial discharge resistant electrical insulation systems (Type II) used in rotating electrical machines fed from voltage converters - Qualification tests (IEC 2/1798/CDV)
IEC/TS 60034-24	Rotating electrical machines - Part 24: Online detection and diagnosis of potential failures at the active parts of rotating electrical machines and of bearing currents - Application guide (IEC/TS 60034-24)
IEC 2/1689/CD	Rotating electrical machines - Part 25: AC machines when used in power drive systems - Application guide (IEC 2/1689/CD)
DIN EN 60034-30-1	Rotating electrical machines - Part 30-1: Efficiency classes of line operated AC motors (IE code) (IEC 60034-30-1)
DIN CLC/TS 60034-31	Rotating electrical machines - Part 31: Selection of energy-efficient motors including variable speed applications - Application guide (IEC/TS 60034-31)
DIN 748-3	Cylindrical shaft ends - Part 3: For rotating electrical machinery
DIN SPEC 42955	Shaft extension run out and of mounting flanges for rotating electrical machinery, frame size larger than 315 - Tolerances, test
DIN EN 50347	General purpose three-phase induction motors having standard dimensions and outputs - Frame numbers 56 to 315 and flange numbers 65 to 740
DIN 6885-1	Drive Type Fastenings without Taper Action; Parallel Keys, Keyways, Deep Pattern
DIN 332-2	Center holes 60° with thread for shaft ends for rotating electrical machines

1 Basic Safety Instructions

The COMBIVERT is designed and constructed in accordance with state-of-the-art technology and the recognized safety rules and regulations. However, the use of such devices may cause functional hazards for life and limb of the user or third parties, or damages to the system and other material property.

The following safety instructions have been created by the manufacturer for the area of electric drive technology. They can be supplemented by local, country- or application-specific safety instructions. This list is not exhaustive. Violation of the safety instructions by the customer, user or other third party leads to the loss of all resulting claims against the manufacturer.

NOTICE



Hazards and risks through ignorance.

- ▶ Read the instructions for use !
- ▶ Observe the safety and warning instructions !
- ▶ If anything is unclear, please contact KEB Automation KG !

1.1 Target group

This instruction manual is determined exclusively for electrical personnel. Electrical personnel for the purpose of this instruction manual must have the following qualifications:

- Knowledge and understanding of the safety instructions.
- Skills for installation and assembly.
- Start-up and operation of the product.
- Understanding of the function in the used machine.
- Detection of hazards and risks of the electrical drive technology.
- Knowledge of *DIN IEC 60364-5-54*.
- Knowledge of national safety regulations.

1.2 Transport, storage and proper use

The transport is carried out by qualified persons in accordance with the environmental conditions specified in this manual. Motors shall be protected against excessive strains.



Damage due to improper transport

- ▶ Transport only on suitable devices (folding boxes, transport frames, flat pallets, usw)!
- ▶ Avoid any impacts, sharp sudden movements and strong vibrations!
- ▶ Motors must only be lifted and placed at creeping speed to prevent damage to the bearings!

Do not store Motors

- in the environment of aggressive and/or conductive liquids or gases.
- with direct sunlight.
- outside the specified environmental conditions.

To prevent damage to the motor:

- Check if necessary and do not remove anti-corrosive coat at the shaft ends, flange surfaces etc.
- No vibrations may occur in the storage location.
- In case of storage longer than 3 months, rotate the motor in both directions at a slow speed (< 100 rpm) to allow the grease to distribute evenly in the bearings.
- If necessary, rotate the rotor at least once a year several times, in order to avoid corrosion on the bearings.

1.3 Installation

⚠ DANGER



Do not operate in an explosive environment!

- ▶ The COMBIVERT is not intended for the use in potentially explosive environment.

⚠ CAUTION



Maximum design edges and high weight!

Contusions and bruises!

- ▶ Never stand under suspended loads.
- ▶ Wear safety shoes.
- ▶ Secure motor accordingly when using lifting gear.

To prevent damages to the motor:

- Make sure that isolation distances will be respected in the terminal box.
- Before commissioning motors with a shaft key, secure the key to ensure that it cannot be thrown out if this is not already prevented by driving elements such as a belt pulley, coupling, etc.
- The motor must not be put into operation in case of mechanical defects.
- Do not allow moisture or mist to penetrate the motor.
- Avoid dust permeating the device.
- Note installation position and minimum distances to surrounding elements. Do not cover the ventilation openings.
- Make sure that no small parts fall into the motor during assembly and wiring (drilling chips, screws etc.). This also applies to mechanical components, which can lose small parts during operation.
- Check for reliable fit of device connections in order to minimize contact resistance and avoid sparking.
- Do not climb on the motor housing.
- Follow all safety instructions!

1.4 Connection instructions

DANGER



Voltage at the terminals and in the motor!

Danger to life due to electric shock!

- ▶ Never work on the open device or touch exposed parts. During the operation (even at zero speed) the motors posses dangerous live parts.
- ▶ For any work on the motor switch off the supply voltage and secure it against switching on.
- ▶ Wait until the drive has stopped in order, that perhaps regenerative energy can be generated.
- ▶ Never bridge upstream protective devices (even for testing purposes.).
- ▶ Connect the protective earth conductor to drive converter and motor.
- ▶ Install all required covers and protective devices for operation.

For a trouble-free and safe operation, please pay attention to the following instructions:

- The electrical installation shall be carried out in accordance with the relevant requirements.
- The motors are not designed for direct connection to the three-phase system but are to be operated via an electronic power inverter.
- Connect the temperature sensor to protect the motor against slow thermal changes. Temperature sensors do not represent an all-around protection of the winding. Measures must be taken in the parameterisation of the inverter for the protection against fast thermal changes (e.g. I²t-monitoring) !
- Check the proper functioning of the brake (optional).
- An optional holding brake is only designed for a limited number of emergency brakings. Never use it as a working brake. On motors with plug connector and built-in brake, it is the user's responsibility to install the varistor provided to control the brake.

Installations with additional safety or protective measures in accordance with their requirements have to be checked, when using drive converters, to be in accordance with the given application notes or recommendation when using these!

1.4.1 EMC-compatible installation

Observance of the limit values required by EMC law is the responsibility of the customer.



Notes on EMC-compatible installation can be found here.
www.keb.de/fileadmin/media/Manuals/dr/emv/0000neb0000.pdf



1.5 Start-up and operation

The drive controller must not be started until it is determined that the installation complies with the machine directive; Account is to be taken of [EN 60204-1](#).

⚠ WARNING

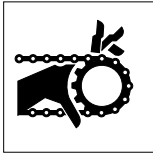

Software protection and programming!

Hazards caused by unintentional behavior of the drive!

- ▶ Check especially during initial start-up or replacement of the drive controller if parameterization is compatible to application.
- ▶ Securing a unit solely with software-supported functions is not sufficient. It is imperative to install external protective measures (e.g. limit switch) that are independent of the drive controller.
- ▶ Secure motors against automatic restart.

⚠ CAUTION



High temperatures at heat sink and coolant!

Burning of the skin!

- ▶ Cover hot surfaces safe-to-touch.
- ▶ Before working let the motor cool down.
- ▶ Before touching, check the surface and cooling water lines.
- ▶ If necessary, attach warning signs on the system.

Switching at the output

Switching between motor and drive controller is prohibited for single drives during operation as this may trigger the protection gear of the device. Function ‚speed search‘ must be activated if switching can not be avoided. Speed search may only be triggered after closing the motor contactor (e.g. by switching the control release).

Connecting and disconnecting is permissible with multiple motor drives if at least 1 motor is running during the switch-over process. The drive controller must be dimensioned to the occurring starting currents.

The ‚speed search‘ function must be activated if the motor is still running during a restart of the drive controller (mains on) (e.g. due to large rotating masses).

1.6 Maintenance

The following maintenance work must be carried out as required, but at least once a year, by authorized and instructed personnel.

- ▶ Check unit for loose screws and plugs and tighten if necessary.
- ▶ Clean motor from dirt and dust deposits. Pay attention especially to cooling fins and protective grid of the fans.
- ▶ Check the function of the fans of the drive converter. The fan must be replaced in case of audible vibrations or squeaking.

1.7 Repair

In case of malfunction, unusual noises or smells inform a person in charge!

DANGER



Unauthorized exchange, repair and modifications!

Unpredictable malfunctions!

- ▶ The function of the drive controller is dependent on its parameterization. Never replace without knowledge of the application.
- ▶ Modification or repair is permitted only by KEB Automation KG authorized personnel.
- ▶ Only use original manufacturer parts.
- ▶ Infringement will annul the liability for resulting consequences.

In case of failure, please contact the machine manufacturer. Only the machine manufacturer knows the parameterisation of the used drive controller and can provide an appropriate replacement or induce the maintenance.

1.8 Disposal

Electronic devices of the KEB Automation KG are exclusively professional devices for further industrial processing (so-called B2B devices).

Manufacturers of B2B devices are obliged to take back and recycle devices manufactured after 14.08.2018. These devices may not be disposed at the collection centres of public sector disposal organisations.



If no deviating agreement has been made between the customer and KEB or no deviating mandatory legal regulation exists, KEB products marked in this way can be returned. Company and keyword to the return point can be taken from the list below. Shipping costs are paid by the customer. Thereupon the devices will be professionally recycled and disposed.

The entry numbers are listed country-specific in the following table. The corresponding KEB return addresses can be found on our website.

Withdrawal by	WEEE-Reg.-No.	Keyword
Austria		
KEB Automation GmbH	ERA: 51976	Stichwort „Rücknahme WEEE“
France		
RÉCYLUM - Recycle point	ADEME: FR021806	Mots clés „KEB DEEE“
Germany		
KEB Automation KG	EAR: DE12653519	Stichwort „Rücknahme WEEE“
Italy		
COBAT	AEE: (IT) 19030000011216	Parola chiave „Ritiro RAEE“
Spain		
KEB Automation KG	RII-AEE 7427	Palabra clave „Retirada RAEE“
Česko		
KEB Automation KG	RETELA 09281/20 ECZ	Klíčové slovo: Zpětný odběr OEEZ

The packaging must be feed to paper and cardboard recycling.

2 Product Description

The servo motors of the SMH series are 6, 8 or 10 pole permanent-field synchronous motors with a sine-wave inducted voltage.

2.1 Specified application

The KEB synchronous servo motors are exclusively designed for the operation at digital servo controllers. They are intended for industrial systems only. They comply with the harmonized standards of the series [VDE 0530 / EN 60034-1](#).

The technical data and information for connection conditions can be found on the type plate and the instructions for use and must be complied with.

2.1.1 Residual risks

Despite intended use, the motor can reach unexpected operating conditions in case of error, with wrong parameterization of the drive converter, by faulty wiring or non-professional interventions and repairs. This can be:

- wrong direction of rotation
- motor speed too high
- motor is running into limitation
- motor can be under voltage even in standstill
- automatic start
- motor coasts to standstill

2.2 Unintended use

The operation of our products outside the indicated limit values of the technical data leads to the loss of any liability claims.

2.4 General speed-torque characteristic

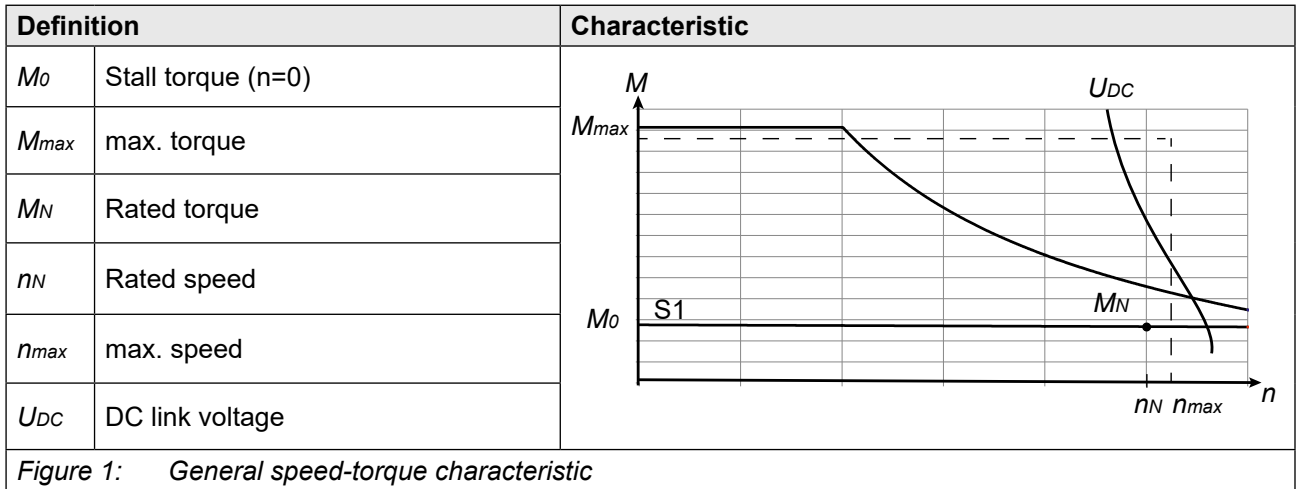

2.5 General project design

2.5.1 Selection of the servo motor

Calculate the following values before you selection the servo motor:

- Determine inertia (J_{App}) of the application without motor.
- Calculate required peak torque (M_{Lmax}) of the application at the drive. The inertia of the motor (J_{Mot}) can be accepted here with 1/5 inertia (J_{App}) of the application.
- Determine the effective torque (M_{eff}) via the time.

Now the motor can be selected on the basis of the calculated values and the technical data of the following pages. The following selection features must be observed:

Calculated data of the application	Motor data
Maximum speed of the application (n_{max})	\leq Rated motor speed (n_N)
required peak torque (M_{Lmax})	\leq Maximum torque (M_{max})
Effective torque (M_{eff})	\leq Rated torque (M_N)
Inertia of the application (J_{App}) / 10	\leq Motor torque (J_{mot})



For examination or optimization it can be calculated again with the real motor data.

2.5.2 Selection of the servo controller

The selection of the servo controller occurs via the max. short time current limit and the rated output current.

$$\text{Max. short time current} = \frac{M_{Lmax} \cdot \text{standstill continuous current } (I_0)}{\text{Stall torque } (M_0)}$$

$$\text{Rated output current} = \frac{\text{effective torque } (M_{eff}) \cdot \text{standstill continuous current } (I_0)}{\text{Stall torque } (M_0)}$$

2.5.3 Output component

The smallest possible effective circular diameter of the output component can be calculated as follows:

$D_W = \frac{k \cdot 2 \cdot M_b}{F_{Rm}}$	D_W	effective circular diameter of the output components
	k	Pretension factor
	F_{Rm}	permissible lateral force
	M_b	Acceleration torque of the drive

2.5.4 Pretension factor

Empirical values for the pretension factor k :

Pinion	$k \approx$	1.5
Toothed belt		1.2...2.0
Flat belt		2.2...3.0

For dynamic processes like braking and accelerating, the permissible lateral force F_R is not to be exceeded in order to avoid a mechanical destruction of the motor.

2.6 Safety function

The fault exclusion of a detaching encoder securement according to [EN 61800-5-2 :2008](#) can be applied for the DL3 motors with resolver.

NOTICE

FS

Fault exclusion for motors with safety technology !

Valid only under the following conditions!

- ▶ The FS logo is printed on the nameplate.

2.7 Construction and definition

2.7.1 Drive end and direction of rotation

Drive end of the motor	View
<p>In EN 60034-7 the two ends of a motor are defined as follows:</p> <p>D (Drive End): Drive end (AS) of the motor.</p> <p>N (Non-Drive End): Non-drive end (BS) of the motor.</p>	<p>The image shows a dark grey motor with a silver shaft. The drive end (D) is on the right, and the non-drive end (N) is on the left. A yellow warning triangle is visible on the top of the motor housing.</p>
<p>Direction of rotation of the motor</p> <p>When the motor terminals U1, V1, W1 are connected to the drive converter output with U, V, W (with this same phase order) the motor rotates in a clockwise direction when viewed facing the D-end.</p>	
<p><i>Figure 2: Example figure of an engine</i></p>	

2.7.2 Winding and insulation system

The insulation materials we use ensure insulation class 155 (F) *EN 60034-1*. Therefore, the winding temperature may be max. 105K at a coolant temperature of +40°C.

The insulation system of the motors is designed such that they can be connected to a drive controller with a maximum DC link voltage $U_{ZK_max} = DC 840V$ (constant DC 690V).



U_{ZK_max} is the maximum value of the DC link voltage which is only transient and approximately equivalent to the inception voltage of the braking transistor or of the regenerative unit.

2.7.3 Holding brake (optional)

The optional built-in holding brake is used to fix the motor shaft when the motor is at standstill or de-energized. It is a permanent-field single-disc brake which operates on the closed-circuit principle, i.e. the brake is effective when the motor is de-energized, thus the motor shaft is held.

Holding brakes are operated on DC current. The rated voltage is 24V. They can be connected to a central DC voltage supply. Overvoltages are not permitted, even not temporary. The excitation current ripple must be less than 20% to ensure reliable opening of the brake and prevent disturbing humming noises.

NOTICE

Do not use the holding brake as a working brake !

Brake failure due to overload !

Check the proper functioning of the brake (optional) after installing the motor. The optional holding brake is only designed for a limited number of emergency brakings. Never use it as a working brake.

NOTICE

Malfunction in case of reverse polarity !

Motor rotation in spite of an active brake!

Since the holding brakes are permanent-magnet brakes, be sure to observe the correct polarity of the DC voltage, otherwise the brake will not open.

Modern (field-oriented) drive converters are able to produce a high torque even at low motor speeds. If the drive converter has sufficient current reserve, a multiple of the rated motor torque can be generated. In this case the motor shaft may turn even if the holding brake is applied, because the holding torque of the brake is exceeded.

NOTICE**Voltage peaks when switching off !****Destruction of the holding brake !**

If the excitation current of the holding brake is switched off on the DC side, a voltage peak occurs which can be higher than 1000 V. It is caused by the inductance of the holding brake. A varistor should be connected in parallel to the coil to prevent this voltage peak.

On motors with plug connector and built-in brake, it is the user's responsibility to install the varistor provided to control the brake.

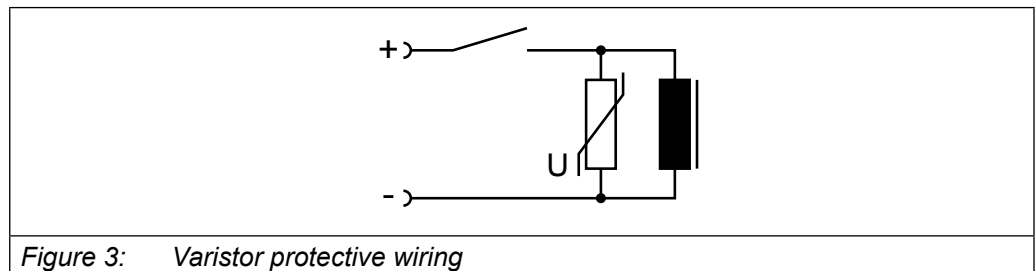

Figure 3: Varistor protective wiring

2.7.4 Speed and shaft position measuring system

The motors are equipped with a resolver, Stegmann Hiperface Singleturn or Stegmann Hiperface Multiturn for speed and shaft position control.

⚠ WARNING**Adjustment of the measuring system!****Injuries due to uncontrolled motor reactions !**

The measuring system of synchronous motors must be adjusted to the respective drive controller. Any mis-adjustment may lead to uncontrolled motor response or complete failure of the motor.

In order to avoid any risk, the motor must be put into operation only in no-load operation, without connection to the system.

2.7.5 Temperature monitoring

KTY84 sensors are installed as standard (except 0xSMH) in the NDE winding head to protect the motor against thermal overload when the temperature change is slow (temperature change in minutes or hours).

NOTICE

Operating voltage too high !

Destruction of the temperature sensor !

- ▶ The maximum operating voltage of the temperature sensor must not exceed DC 30V.

Due to the non-ideal thermal coupling, the temperature sensor follows rapid winding temperature changes only with delay, thus being unable to protect the winding if the thermal overload of the motor is transient and high. Therefore, additional protection is required (e.g. monitoring $I^2 \times t$ by the drive converter) to protect the motor from fast-rising thermal overload.

NOTICE

Avoid rapid temperature changes !

Damage to the motor winding due to overload !

The evaluation of the temperature sensor belongs to the monitoring of the motor winding. The temperature sensor follows rapid temperature changes only with delay.

The characteristics apply in case of a failure. They must not be applied for normal motor operation.

NOTICE

Not for use in continuous operation !

Damage to the motor !

- ▶ The effective value of the motor current is not permitted to exceed the rated continuous current !

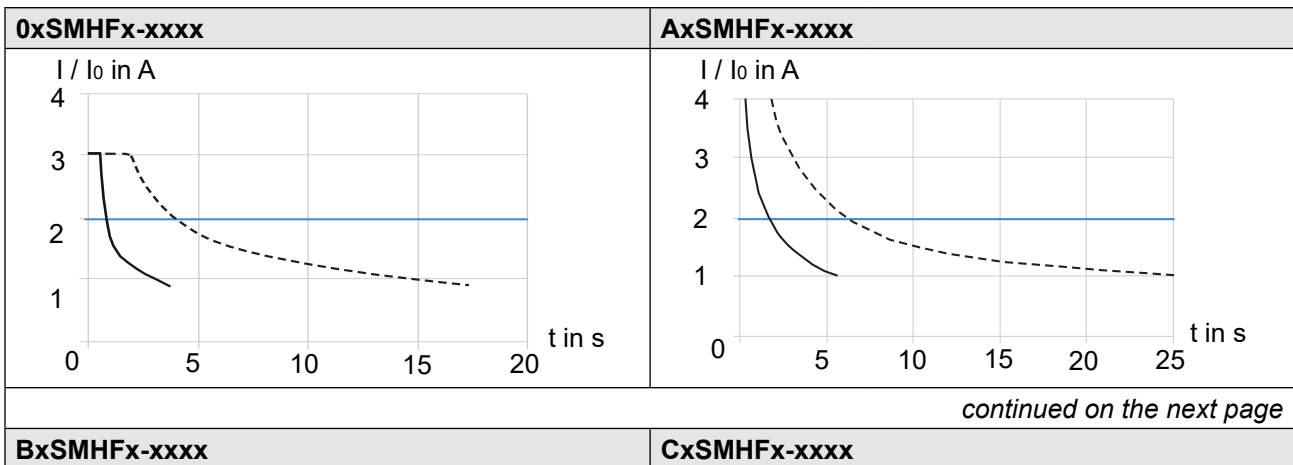

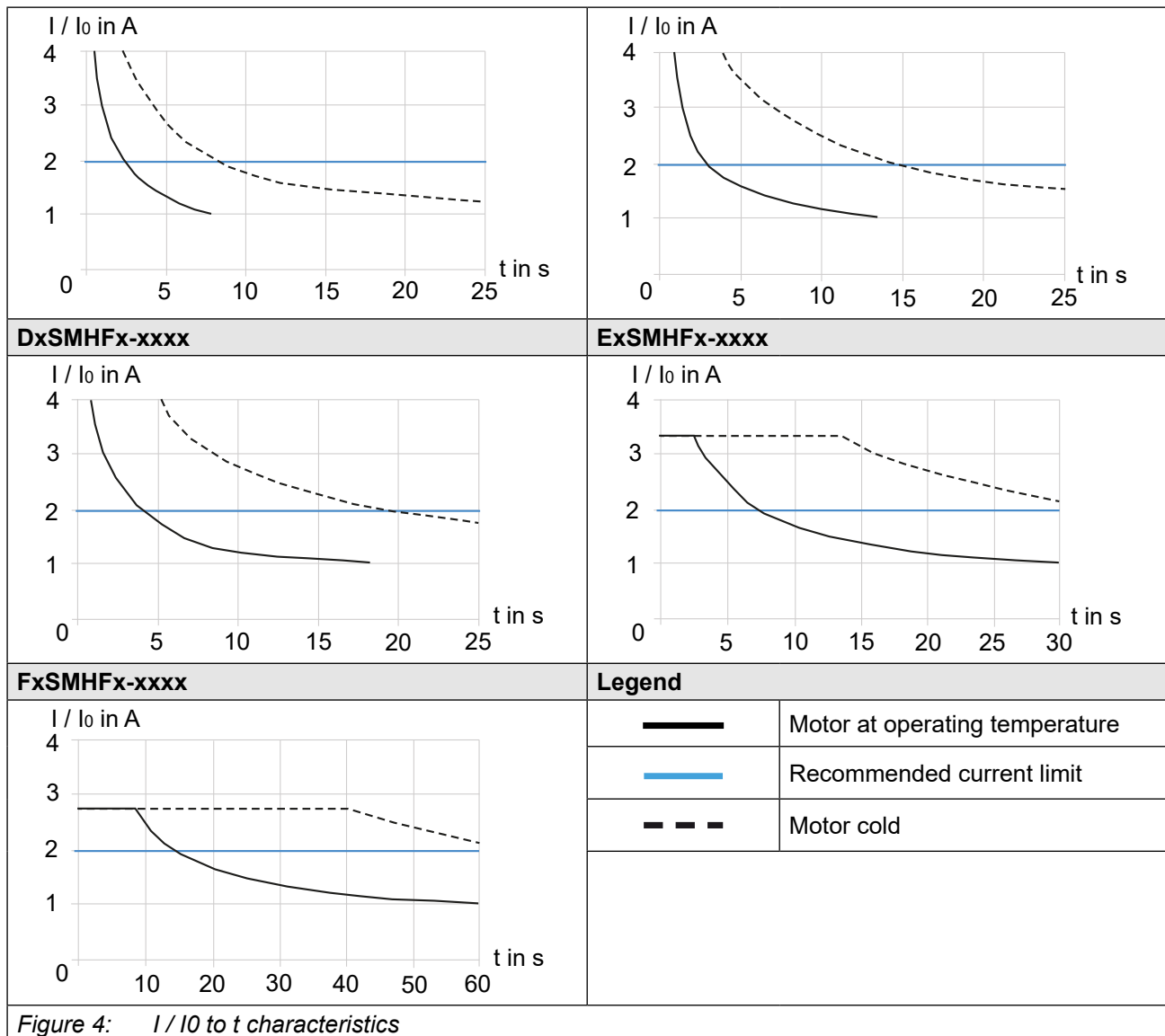

Figure 4: I / I_0 to t characteristics

3 Operating Conditions

3.1 Product features of the DL3 servo motors

Feature	Standard	Option
Type	IM B5 (IM V1, IM V3)	
Degree of protection	IP54	With shaft sealing ring IP65 (except 0xSMH)
Motor type	Permanent magnet synchronous servo motor	
Magnetic material	Neodymium iron boron	
Nominal rating	valid for S1 operation	
Vibration severity level	B	
Flange accuracy	N	r
Insulation class	Temperature rise class F (155°C)	
Winding protection	KTY 84-130 in stator winding (except 0xSMH)	
Connection	At size 0: Plug (rotatable, yTec)	
	From size C: angular flange socket, Size 1	
	From size F: (E2 separately ventilated), angular flange socket, size 1.5	
Encoder system connection	Connector (rotatable, y / iTec -compatible)	
Encoder system	2-pole Resolver pretended by KEB	
	Stegmann Hiperface Singleturn SKS36, 128 increments per revolution	
	Stegmann Hiperface Multiturn SKM36, 128 increments per revolution	
Cooling	Self-cooling	
Brake	-	Permanent-field holding brake
Motor coating	Powder coating	
Bearing	Radial groove ball bearings with lifetime lubrication	
Bearing - lifetime	The average bearing lifetime under rated conditions is 30,000 h.	
Shaft end	Smooth shaft end	Shaft end with keyway
Ambient temperature	-20°C...+40°C	
<i>Table 2: Product features</i>		

3.2 Test flange for thermal determinations

The rated power (rated torque) applies for continuous operation (duty type S1) at ambient temperature of 40°C and site altitude of up to 1,000 m above sea level.

Motor type	Material	Dimension of the test flange in mm
0xSMH	Aluminium	230 x 130 x 10
AxSMH	Steel	225 x 80 x 10
BxSMH	Aluminium	230 x 130 x 10
CxSMH	Aluminium	230 x 130 x 10
DxSMH	Aluminium	305 x 305 x 12,7
ExSMH	Aluminium	380 x 170 x 10
FxSMH	Steel	375 x 601 x 10

Table 3: Dimensions and material of the test flange



If the motor flange is thermally insulated, it is not able to dissipate the motor heat. This requires a reduction of the rated motor torque.

3.3 Coolant temperature at different site altitudes

At higher temperatures or site altitudes, the load capability of the motors is reduced (see the following table).

Altitude above sea level in m	Coolant temperature in °C					
	<30	30...40	45	50	55	60
1000	1.07	1.00	0.96	0.92	0.87	0.82
1500	1.04	0.97	0.93	0.89	0.84	0.79
2000	1.00	0.94	0.90	0.86	0.82	0.77
2500	0.96	0.90	0.86	0.83	0.78	0.74
3000	0.92	0.86	0.82	0.79	0.75	0.70
3500	0.88	0.82	0.79	0.75	0.71	0.67
4000	0.82	0.77	0.74	0.71	0.67	0.63

Table 4: Coolant temperature

⚠ CAUTION



High surface temperatures!

Fire and burn protection !

- ▶ The motors can reach a surface temperature of more than 100 °C.
- ▶ No temperature-sensitive parts shall be connected or fastened. If necessary, protective measures must be taken against touching.

3.4 Degree of protection of servo motors

The housings of the servo motors SMH series are generally designed to meet degree of protection IP54 as specified in DIN *EN 60034-5*. See table below for the respective sealing.

Shaft sealing	Degree of protection	User information
Standard	IP54	The effect to moisture in the shaft and flange area must be kept to a minimum. No liquid may remain in the D end shield, if the motor is mounted with the "shaft end upward" (IM V3, IM V36).
With shaft sealing ring	IP65 (except 0xSMH)	

Table 5: IP Degree of protection of servo motors



The specific degree of protection can only be complied, if the drive is mounted to a gear box and the motor plug is properly attached!

NOTICE

Insufficient lubrication of the motor !

Destruction of the sealing lip !

When using a shaft seal ring, note that the sealing lip needs to be sufficiently lubricated and cooled with a high-quality mineral oil such as SAE 20 to ensure the proper functioning of the seal. Sufficient lubricant supply is required for proper heat dissipation.

If the shaft seal is greased, the maximum permissible motor speed may need to be reduced.

Regular regreasing is imperative!

Excessive peripheral speeds destroy the sealing lip and its protective function is no longer guaranteed.

3.4.1 Usage of connector systems

If connector systems are used, then the type of protection IP65 is only achieved with correctly wired and firmly tightened mating connector. In the case of improper execution of the work the type of protection IP65 is no longer warranted.

4 Connection

4.1 Rotatability of flange sockets

The connection must be carried out in such a way that a permanently safe, electrical connection is maintained. By manually turning the flange sockets any outgoing cable direction can be adjusted in the range of 300°. In addition, there are four locking points at 90°.

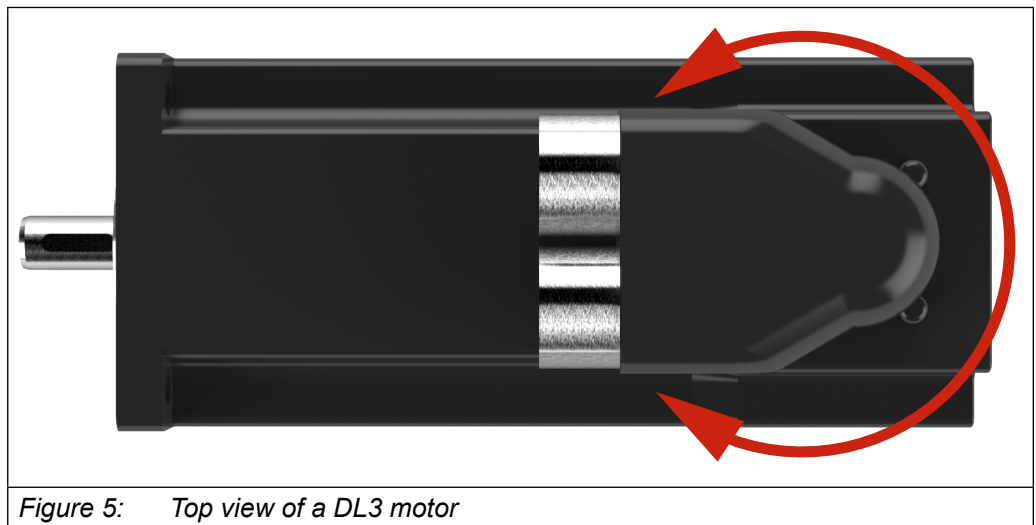

Figure 5: Top view of a DL3 motor

4.2 Connectors

Size	0xSMH...BxSMH	
	Encoder connection	Motor connection
		
Size	C1SMH ... E3SMH	
	Encoder connection	Motor connection
		
Size	FxSMH	
	Encoder connection	Motor connection
		

Figure 6: Connectors with a view to the connection pins at the motor

4.3 Motor connection

Size	0xSMH...BxSMH		C1SMH...E3SMH	
	Connection	Signal	Connection	Signal
	A	Motor phase U	1	Motor phase U
	B	Motor phase V	4	Motor phase V
	C	Motor phase W	3	Motor phase W
	⊕	PE	2 / ⊕	PE
	1	Brake + (option)	A	Brake + (option)
	2	Brake - (option)	B	Brake - (option)
	3	Temperature detector +	C	Temperature detector +
	4	Temperature detector -	D	Temperature detector -
	5	-		

Size	FxSMH																			
		<table border="1"> <thead> <tr> <th>Connection</th> <th>Signal</th> </tr> </thead> <tbody> <tr> <td>U</td> <td>Motor phase U</td> </tr> <tr> <td>V</td> <td>Motor phase V</td> </tr> <tr> <td>W</td> <td>Motor phase W</td> </tr> <tr> <td>⊕</td> <td>PE</td> </tr> <tr> <td>+</td> <td>Brake + (option)</td> </tr> <tr> <td>-</td> <td>Brake - (option)</td> </tr> <tr> <td>1</td> <td>Temperature detector +</td> </tr> <tr> <td>2</td> <td>Temperature detector -</td> </tr> </tbody> </table>	Connection	Signal	U	Motor phase U	V	Motor phase V	W	Motor phase W	⊕	PE	+	Brake + (option)	-	Brake - (option)	1	Temperature detector +	2	Temperature detector -
Connection	Signal																			
U	Motor phase U																			
V	Motor phase V																			
W	Motor phase W																			
⊕	PE																			
+	Brake + (option)																			
-	Brake - (option)																			
1	Temperature detector +																			
2	Temperature detector -																			

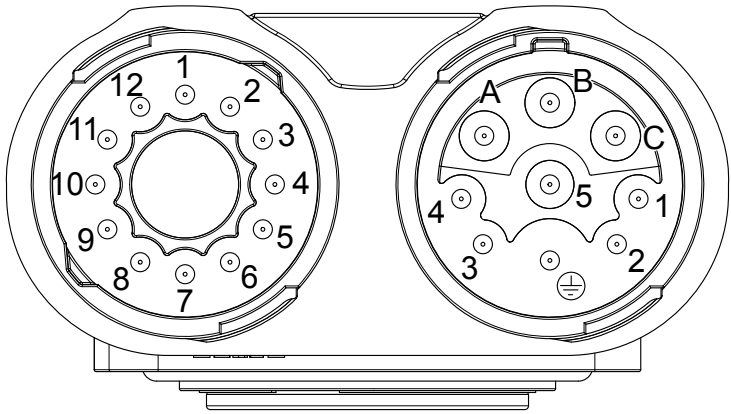
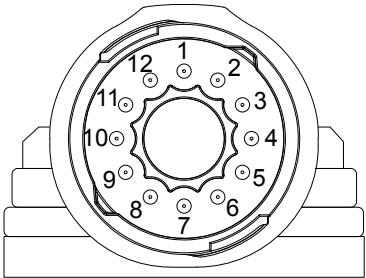
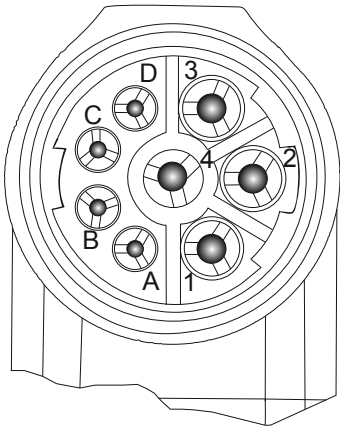
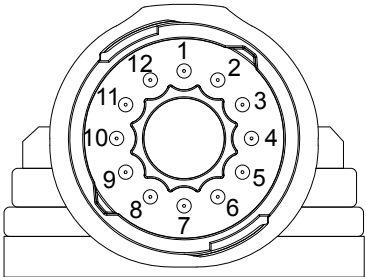
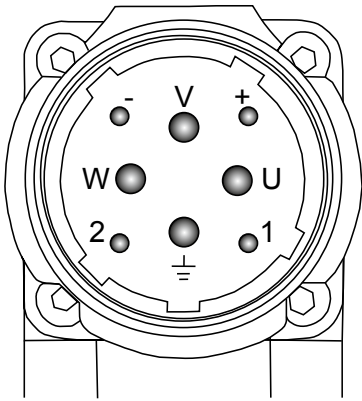
Figure 7: Motor connector terminal assignment with a view to the connection pins at the motor



The 0xSMH motors do not have winding protection. PIN 3 and 4 without function.

4.4 Encoder connection



Subsequent adjustment of the measuring system

Malfunction and uncontrolled reactions of the motor !

The measuring system of synchronous motors must be adjusted to the respective drive controller. Any mis-adjustment may lead to uncontrolled motor response or complete failure of the motor.

In order to avoid any risk, the motor must be put into operation only in no-load operation, without connection to the system.

4.4.1 Resolver terminal assignment

Description	View	Pin No.	KEB marking	Resolver signal
View to the connector pins of the resolver connector		1	SIN-	S4
		2	COS-	S1
		3	-	-
		4	-	-
		5	REF-	R1
		6	-	-
		7	REF+	R2
		8	-	-
		9	-	-
		10	SIN+	S2
		11	COS+	S3
		12	-	-
		Housing	Shield	Shield

Figure 8: Resolver terminal assignment

4.4.2 Hiperface terminal assignment

Description	View	Pin No.	Signal
View to the connector pins of the hiperface connector		1	-
		2	-
		3	-
		4	SIN-
		5	COS-
		6	Data+
		7	Data-
		8	SIN+
		9	COS+
		10	+7.5V
		11	COM
		12	-
		Housing	Shield

Figure 9: Hiperface terminal assignment



The pin assignment for Hiperface single / multi-turn encoders is identical.

5 Technical Data

5.1 Permissible axial and radial forces

The maximum permissible axial and radial forces must not be exceeded in order to ensure smooth running of the motor.

- The forces charge the mid-shaft end.
- The radial forces F_R are depending on the speed n .
- The max. radial forces occur at more than 50 rpm at speed n .
- The axial forces F_A are depending on the radial forces F_R .

Motor type	n_{max} / rpm	F_{Rmax} / N	F_R in dependence of n					F_A / N	F_{Amax} / N
			20% * n_{max}	40% * n_{max}	60% * n_{max}	80% * n_{max}	100% * n_{max}		
01SMHF	8000	320	168.7	133.9	117	106.3	98.7	0.2 * F_R	160
02SMHF	8000	300	184.5	146.4	127.9	116.2	107.9		
03SMHF	8000	280	194.2	154.1	134.7	122.3	113.6		
A1SMHF	8000	500	240.0	190.5	166.4	151.2	140.4	0.2 * F_R	340
A2SMHF	8000	470	268.5	213.1	186.2	169.2	157.0		
A3SMHF	8000	420	286.0	227.0	198.3	180.2	167.3		
B1SMHF	6000	1000	476.1	377.9	330.1	299.9	278.4	0.3 * F_R	760
B2SMHF	6000	950	534.1	423.9	370.3	336.5	312.3		
B3SMHF	6000	900	571.1	453.3	396.0	359.8	432.0		
C1SMHF	6000	1300	617.0	489.7	427.8	388.7	360.8	0.35 * F_R	1200
C2SMHF	5000	1250	749.8	595.1	519.9	472.4	438.5		
C3SMHF	5000	1200	807.9	641.2	560.1	508.9	472.4		
D1SMHF	5000	1650	671.2	532.7	465.4	422.8	392.5	0.3 * F_R	1200
D2SMHF	4000	1550	845.9	671.4	586.5	532.9	494.7		
D3SMHF	4000	1450	921.5	731.4	639.0	593.1	538.9		
E1SMHF	3000	3400	1955.3	1551.9	1355.7	1231.7	1143.4	0.3 * F_R	2800
E2SMHF	3000	3200	2252.8	1788.0	1562.0	1419.2	1317.4		
E3SMHF	3000	3000	2440.2	1936.8	1691.9	1537.2	1427.0		
F1SMHF	3000	5600	3155.7	2504.7	2188.1	1988.0	1845.5	0.3 * F_R	4800
F2SMHF	2000	5400	4170.3	3309.9	2891.5	2627.1	2438.8		
F3SMHF	2000	5200	4510.4	3579.9	3127.3	2841.4	2637.7		

Table 6: Permissible axial and radial forces

The endurance strength of the shaft and the bearing life (30.000 h) are decisive for the permissible radial forces F_R . Taking the endurance strength into consideration F_R is not permitted to be exceeded even during dynamic processes (acceleration, braking).

F_A	Axial force	
F_R	Radial force	
x	Length of the rotor shaft up to the center of the radial force	
l	Length of the rotor shaft	

Figure 10: Axial and radial forces

5.2 Shaft end

Motors of the SMH series have cylindrical shaft ends according to *DIN 748*. Use suitable devices for mounting and pulling off driving elements such as gears, pulleys, couplings, etc. Support the device at the D(AS) shaft end.

NOTICE

No impacts or axial forces on the shaft end !

Damage to the motor and the motor shaft !

- ▶ Motor and motor shaft must be protected against shocks and impacts!

	Shaft end		
	Motor type	D1	L1 / mm
	0xSMH	Ø 8 h7	22.5
	AxSMH	Ø 9 k6	20
	BxSMH	Ø 14 k6	30
	CxSMH	Ø 19 k6	40
	DxSMH	Ø 24 k6	50
	ExSMH	Ø 32 k6	58
	FxSMH	Ø 38 k6	80

Figure 11: Shaft end

5.3 Technical data servo motors 0xSMHFx-xxxx

Motor type		01	02	03
Stall torque	M_0 / Nm	0.2	0.38	0.52
Current at stall torque	I_0 / A	0.76	1.3	1.65
Rated motor frequency	f / Hz	400		
Rated current	I_N / A	0.73	1.2	1.3
Max. torque	M_{max} / Nm	0.68	1.37	2.04
Max. current	I_{max} / A	2.3	4.55	5.9
Max. speed <i>Mech</i>	n_{max} / rpm	10000		
Winding resistance	¹⁾ R_{u-v} / Ω	34.5	15	11.5
Winding inductance	¹⁾ L_{u-v} / mH	21	10.5	9
Voltage constant	¹⁾ $k_e / \text{V}_{pk}/1000 \text{ rpm}$	27	27	32
Inertia	²⁾ J_L / kgcm^2	0.02	0.04	0.06
Mass	²⁾ m / kg	0.62	0.74	0.86
Number of pole pairs	p	3		

Table 7: Technical data servo motors 0xSMHFx-xxxx

¹⁾ From phase to phase at 20°C.

²⁾ With encoder connection, without holding brake.

Motor type		01	02	03
Rated voltage	U_N / V	230		
Rated speed	n_N / rpm	8000		
Rated torque	M_N / Nm	0.18	0.33	0.45
Rated power	P_N / kW	0.15	0.28	0.38

Table 8: Rated voltage-dependent technical data servo motors 0xSMHFx-xxxx

5.3.1 Technical data of the holding brake 02P1320-0407

Holding brake		02P1320-0407		
Motor type		01	02	03
Holding torque at 120°C	M_{Br} / Nm	0.6		
Rated voltage	U_{Br_dc} / V	24		
Power input at 24V	P_{Br} / W	10		
Brake release time	t_1 / ms	14		
Brake closing time	t_2 / ms	8		
Inertia	¹⁾ J_{Br} / kgcm ²	0.05	0.07	0.09
Mass	¹⁾ m / kg	0.81	0.93	1.05

Table 9: Technical data of the holding brake 02P1320-0407

¹⁾ For the motor and the holding brake.



The values for parameters co22 and co24 are provided with customer-specific data in the S6 series.

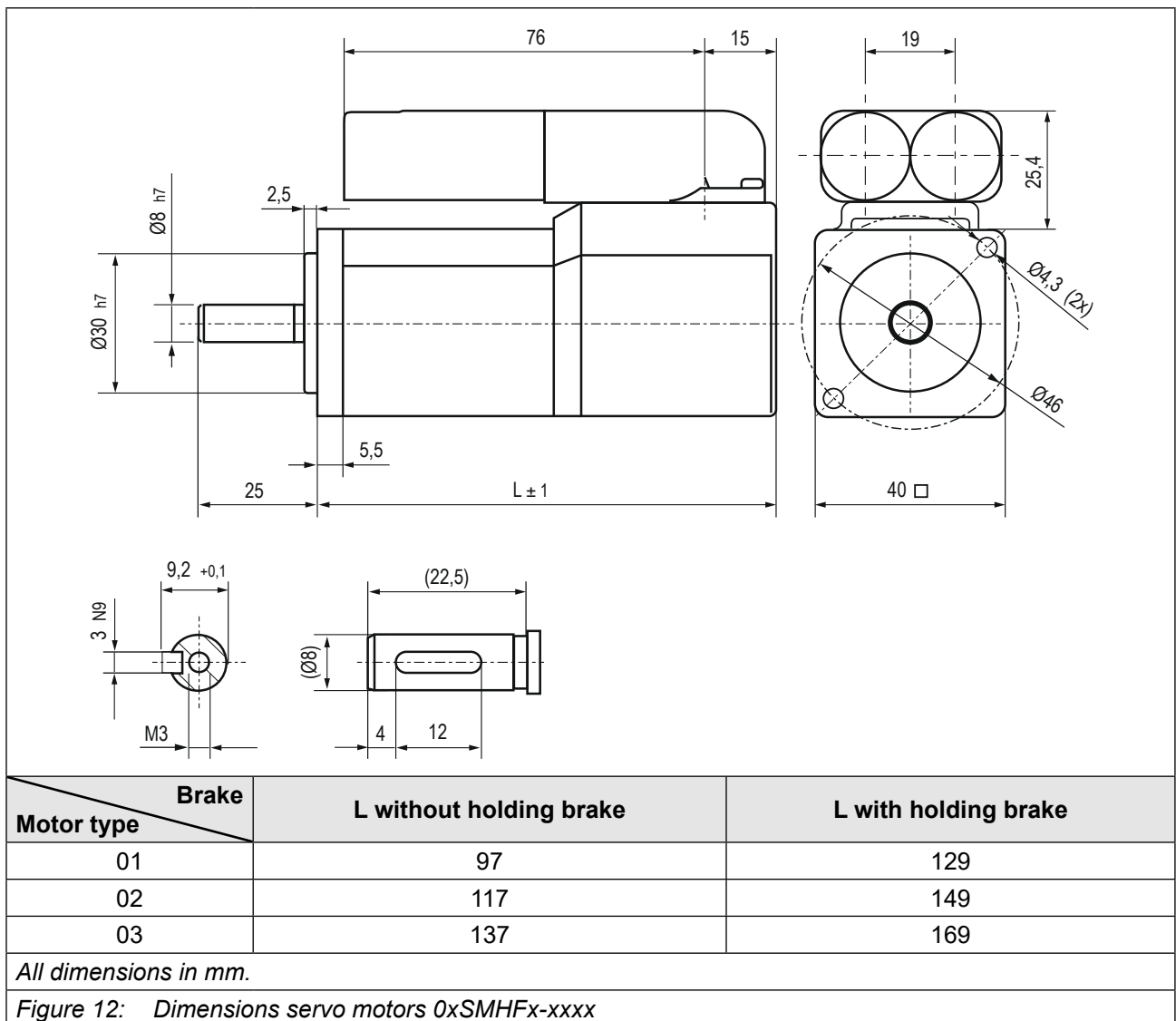

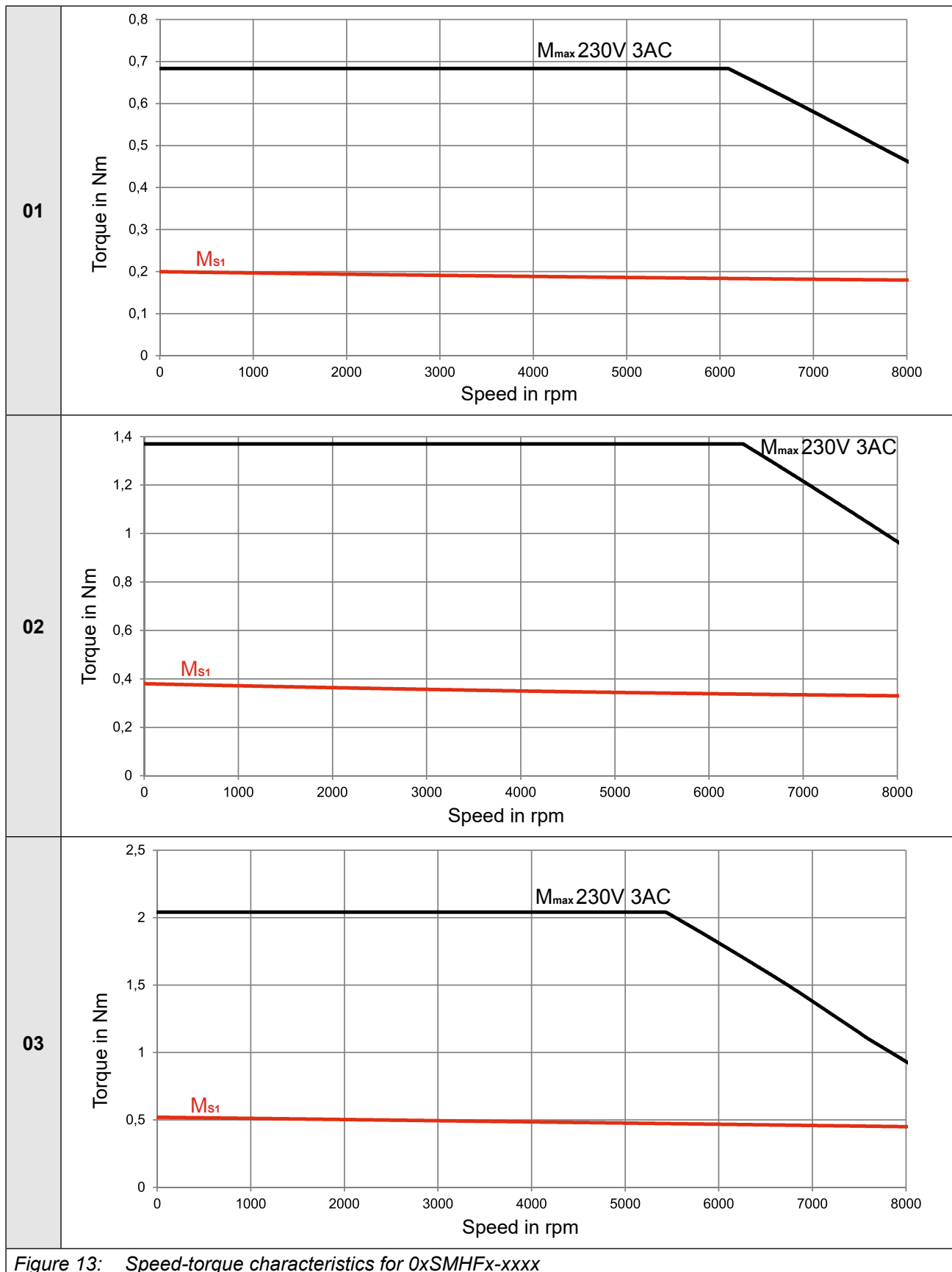

5.4 Technical data servo motors AxSMHFx-xxxx

Motor type		A1	A2	A3
Stall torque	M_0 / Nm	0.5	0.8	1.21
Current at stall torque	I_0 / A	0.85	1.5	2.2
Rated current	I_N / A	0.85	1.3	1.85
Max. torque	M_{max} / Nm	2.69	4.18	6.36
Max. current	I_{max} / A	4.9	7.7	11.4
Max. speed <i>Mech</i>	n_{max} / rpm	12000		
Winding resistance	¹⁾ R_{U-V} / Ω	39.4	13.2	8.5
Winding inductance	¹⁾ L_{U-V} / mH	82.4	36.8	25.2
Voltage constant	¹⁾ $k_e / \text{V}_{pk}/1000 \text{ rpm}$	52	49	52
Inertia	²⁾ J_L / kgcm^2	0.13	0.25	0.37
Mass	²⁾ m / kg	1.0	1.3	1.7
Number of pole pairs	p	3		

Table 10: Technical data servo motors AxSMHFx-xxxx

¹⁾ From phase to phase at 20°C.

²⁾ With encoder connection, without holding brake.

Motor type		A1	A2	A3
Rated voltage	U_N / V	230		
Rated speed	n_N / rpm	4000	4500	
Rated motor frequency	f / Hz	200	225	
Rated torque	M_N / Nm	0.5	0.75	1.1
Rated power	P_N / kW	0.21	0.35	0.52
Rated voltage	U_N / V	400		
Rated speed	n_N / rpm	8000		
Rated motor frequency	f / Hz	400		
Rated torque	M_N / Nm	0.5	0.7	1
Rated power	P_N / kW	0.42	0.59	0.84
Rated voltage	U_N / V	480		
Rated speed	n_N / rpm	9000		
Rated motor frequency	f / Hz	450		
Rated torque	M_N / Nm	0.5	0.65	0.9
Rated power	P_N / kW	0.47	0.61	0.85

Table 11: Rated voltage-dependent technical data servo motors AxSMHFx-xxxx

5.4.1 Technical data of the holding brake 03P1320-1417

Holding brake		03P1320-1417		
Motor type		A1	A2	A3
Holding torque at 120°C	M_{Br} / Nm	2.0		
Rated voltage	U_{Br_dc} / V	24		
Power input at 24V	P_{Br} / W	11		
Brake release time	t_1 / ms	35		
Brake closing time	t_2 / ms	8		
Inertia	¹⁾ J_{Br} / kgcm^2	0.20	0.32	0.44
Mass	¹⁾ m / kg	1.1	1.6	1.9

Table 12: Technical data of the holding brake 03P1320-1417

¹⁾ For the motor and the holding brake.



The values for parameters co22 and co24 are provided with customer-specific data in the S6 series.

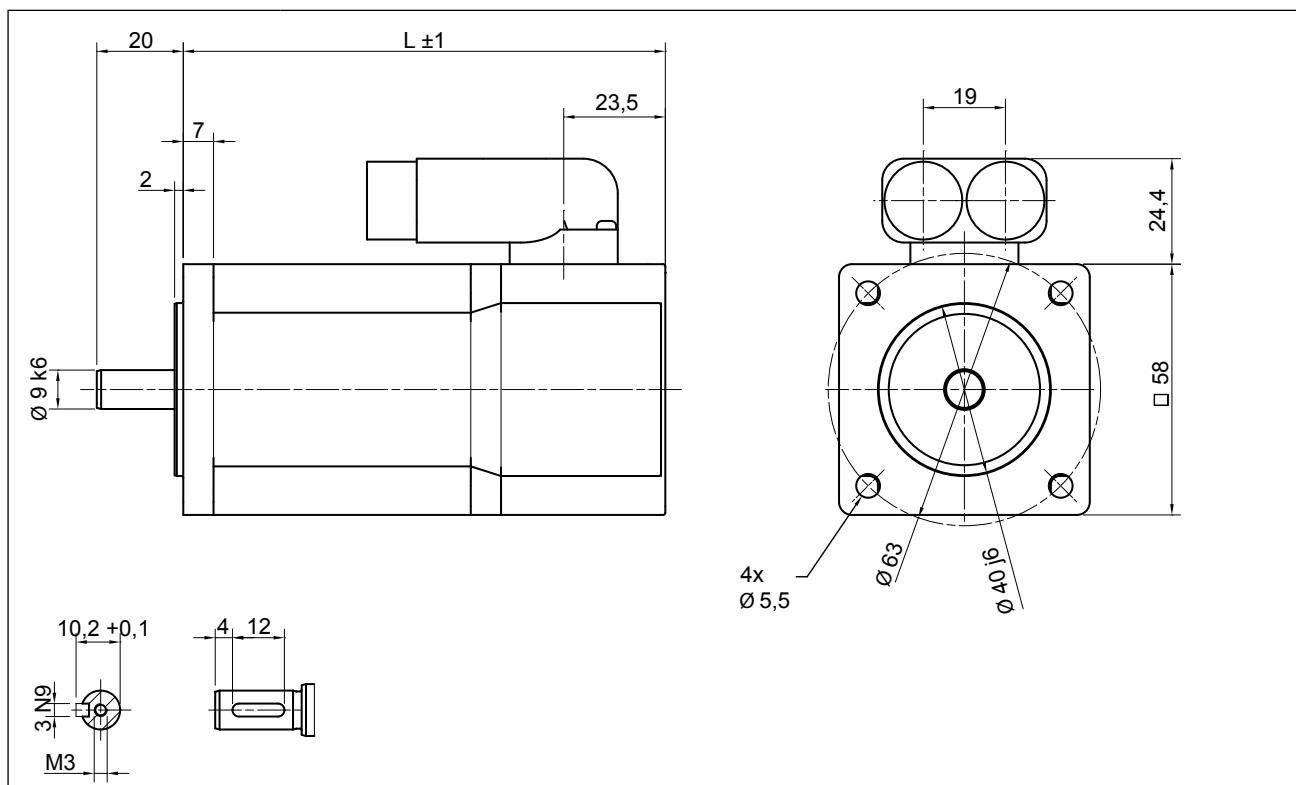

Motor type \ Brake	L without holding brake	L with holding brake
A1	111.5	146
A2	133.5	168
A3	155.5	190

All dimensions in mm.

Figure 14: Dimensions servo motors AxSMHFx-xxxx

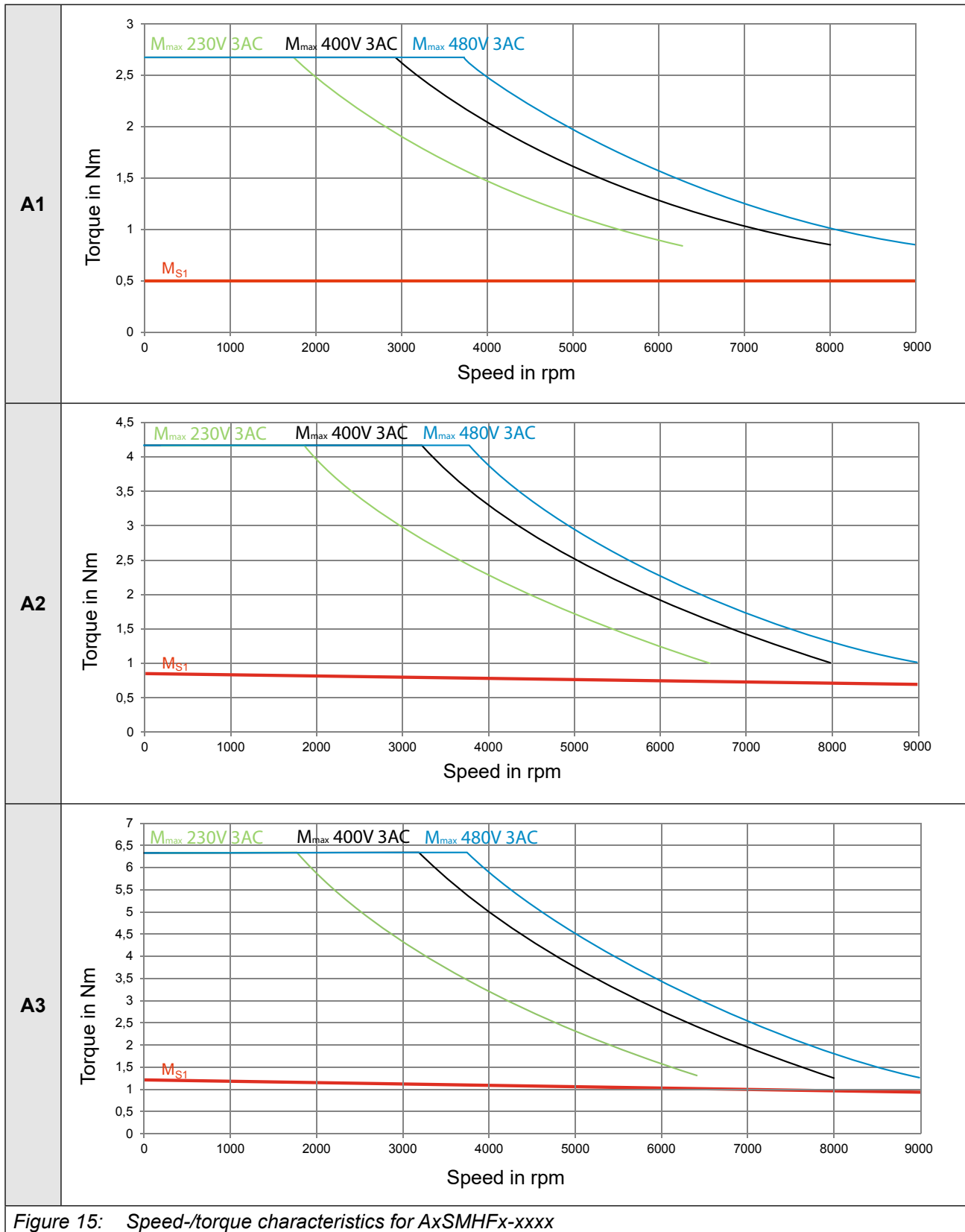

Figure 15: Speed-torque characteristics for AxSMHFx-xxxx

5.5 Technical data servo motors BxSMHFx-xxxx

Motor type		B1	B2	B3
Stall torque	M_0 / Nm	1.38	2.37	3.22
Current at stall torque	I_0 / A	1.95	2.95	4.1
Rated current	I_N / A	1.9	2.75	3.6
Max. torque	M_{max} / Nm	6.07	11.6	17.71
Max. current	I_{max} / A	10.7	17.2	24.6
Max. speed <i>Mech</i>	n_{max} / rpm	10000		
Winding resistance	¹⁾ R_{U-V} / Ω	12.6	6.5	3.9
Winding inductance	¹⁾ L_{U-V} / mH	41.8	28.5	18.8
Voltage constant	¹⁾ $k_e / \text{V}_{pk}/1000 \text{ rpm}$	70.71	79.20	80.61
Inertia	²⁾ J_L / kgcm^2	0.46	0.84	1.22
Mass	²⁾ m / kg	1.8	2.4	3.0
Number of pole pairs	p	4		

Table 13: Technical data servo motors BxSMHFx-xxxx

- ¹⁾ From phase to phase at 20°C.
- ²⁾ With encoder connection, without holding brake.

Motor type		B1	B2	B3
Rated voltage	U_N / V	230		
Rated speed	n_N / rpm	3300	3200	
Rated motor frequency	f / Hz	220	213	
Rated torque	M_N / Nm	1.36	2.28	3
Rated power	P_N / kW	0.47	0.76	1.0
Rated voltage	U_N / V	400		
Rated speed	n_N / rpm	6000		
Rated motor frequency	f / Hz	400		
Rated torque	M_N / Nm	1.33	2.2	2.7
Rated power	P_N / kW	0.84	1.38	1.7
Rated voltage	U_N / V	480		
Rated speed	n_N / rpm	6800		
Rated motor frequency	f / Hz	453		
Rated torque	M_N / Nm	1.32	2.1	2.6
Rated power	P_N / kW	0.94	1.50	1.85

Table 14: Rated voltage-dependent technical data servo motors BxSMHFx-xxxx

5.5.1 Technical data of the holding brake 03P1320-1177 and 05P1320-1077

Holding brake		03P1320-1177		05P1320-1077
Motor type		B1	B2	B3
Holding torque at 120°C	M_{Br} / Nm	2.0	2.0	3.5
Rated voltage	U_{Br_dc} / V	24		
Power input at 24V	P_{Br} / W	11	11	12
Brake release time	t_1 / ms	25		35
Brake closing time	t_2 / ms	8		15
Inertia	¹⁾ J_{Br} / kgcm^2	0.54	0.92	1.46
Mass	¹⁾ m / kg	2.2	2.8	3.6

Table 15: Technical data of the holding brake 03P1320-1177 and 05P1320-1077

¹⁾ For the motor and the holding brake.



The values for parameters co22 and co24 are provided with customer-specific data in the S6 series.

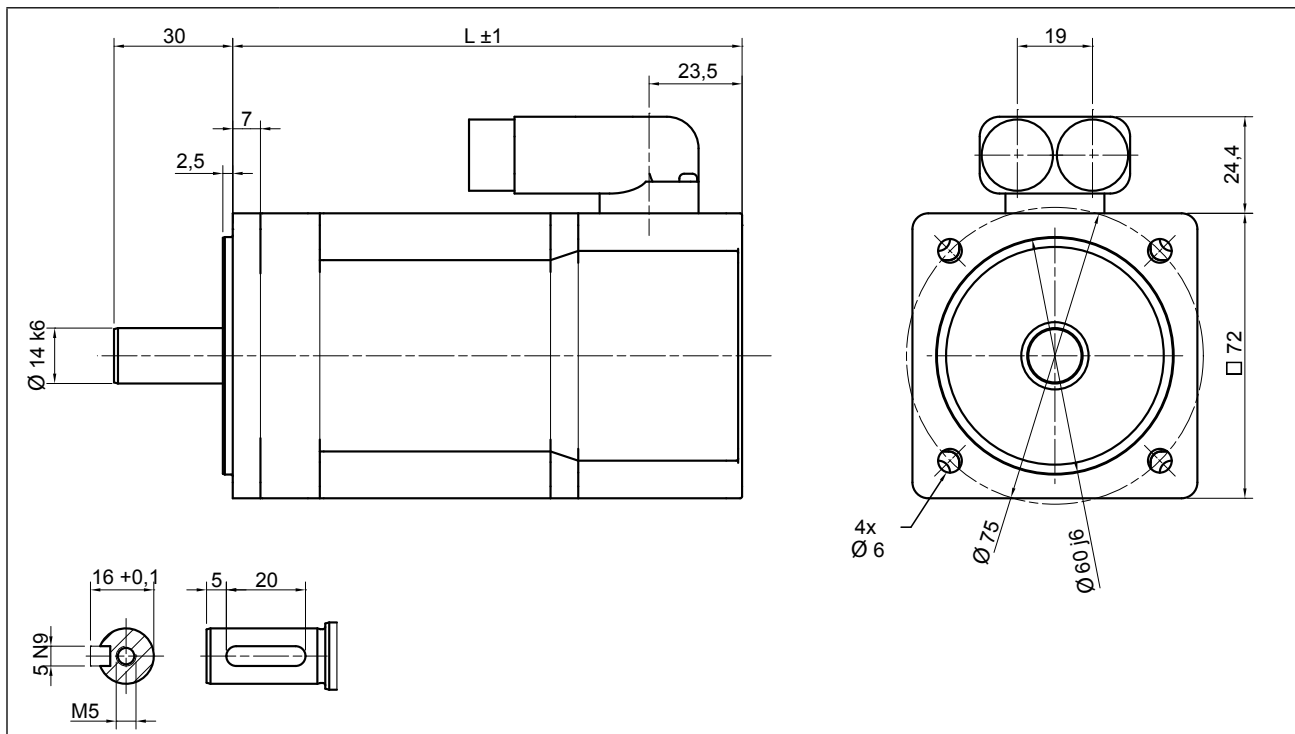

Motor type	Brake	L without holding brake	L with holding brake
	B1		129
B2		154	194
B3		180	229

All dimensions in mm.

Figure 16: Dimensions servo motors BxSMHFx-xxxx

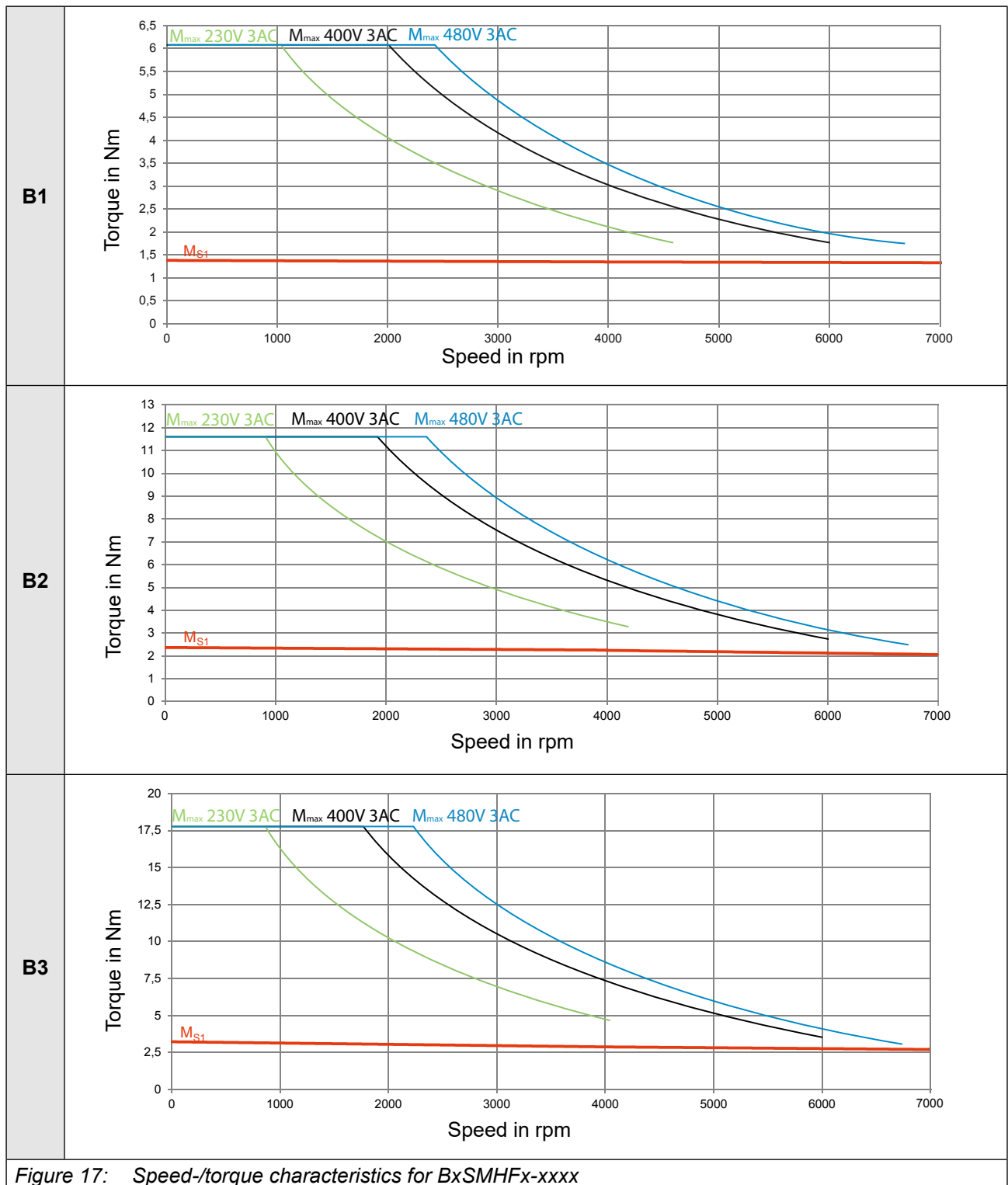

Figure 17: Speed-/torque characteristics for BxSMHFx-xxxx

5.6 Technical data servo motors CxSMHFx-xxxx

Motor type		C1	C2	C3
Stall torque	M_0 / Nm	2.45	4.1	5.65
Current at stall torque	I_0 / A	3.0	4.1	5.4
Rated current	I_N / A	2.9	3.8	4.75
Max. torque	M_{max} / Nm	9.14	18.90	29.25
Max. current	I_{max} / A	13.6	22.7	31.0
Max. speed _{Mech}	n_{max} / rpm	9000		
Winding resistance	¹⁾ R_{U-V} / Ω	6.1	3.7	2.4
Winding inductance	¹⁾ L_{U-V} / mH	29.5	22.2	15.8
Voltage constant	¹⁾ $k_e / \text{V}_{pk}/1000 \text{ rpm}$	79.20	96.17	103.24
Inertia	²⁾ J_L / kgcm^2	1.08	1.98	2.87
Mass	²⁾ m / kg	2.8	3.8	4.9
Number of pole pairs	p	4		

Table 16: Technical data servo motors CxSMHFx-xxxx

¹⁾ From phase to phase at 20°C.

²⁾ With encoder connection, without holding brake.

Motor type		C1	C2	C3
Rated voltage	U_N / V	230		
Rated speed	n_N / rpm	3000	2800	2700
Rated motor frequency	f / Hz	200	187	180
Rated torque	M_N / Nm	2.39	3.9	5.3
Rated power	P_N / kW	0.75	1.14	1.50
Rated voltage	U_N / V	400		
Rated speed	n_N / rpm	6000	5000	
Rated motor frequency	f / Hz	400	333	
Rated torque	M_N / Nm	2.31	3.7	4.9
Rated power	P_N / kW	1.45	1.94	2.57
Rated voltage	U_N / V	480		
Rated speed	n_N / rpm	6800	5700	
Rated motor frequency	f / Hz	253	380	
Rated torque	M_N / Nm	2.27	3.64	4.88
Rated power	P_N / kW	1.62	2.17	2.91

Table 17: Rated voltage-dependent technical data servo motors CxSMHFx-xxxx

5.6.1 Technical data of the holding brake 06P1320-1247

Holding brake		06P1320-1247		
Motor type		C1	C2	C3
Holding torque at 120°C	M_{Br} / Nm		9.0	
Rated voltage	U_{Br_dc} / V		24	
Power input at 24V	P_{Br} / W		18	
Brake release time	t_1 / ms		40	
Brake closing time	t_2 / ms		20	
Inertia	¹⁾ J_{Br} / kgcm^2	1.74	2.63	3.52
Mass	¹⁾ m / kg	3.6	4.7	5.8

Table 18: Technical data of the holding brake 06P1320-1247

¹⁾ For the motor and the holding brake.



The values for parameters co22 and co24 are provided with customer-specific data in the S6 series.

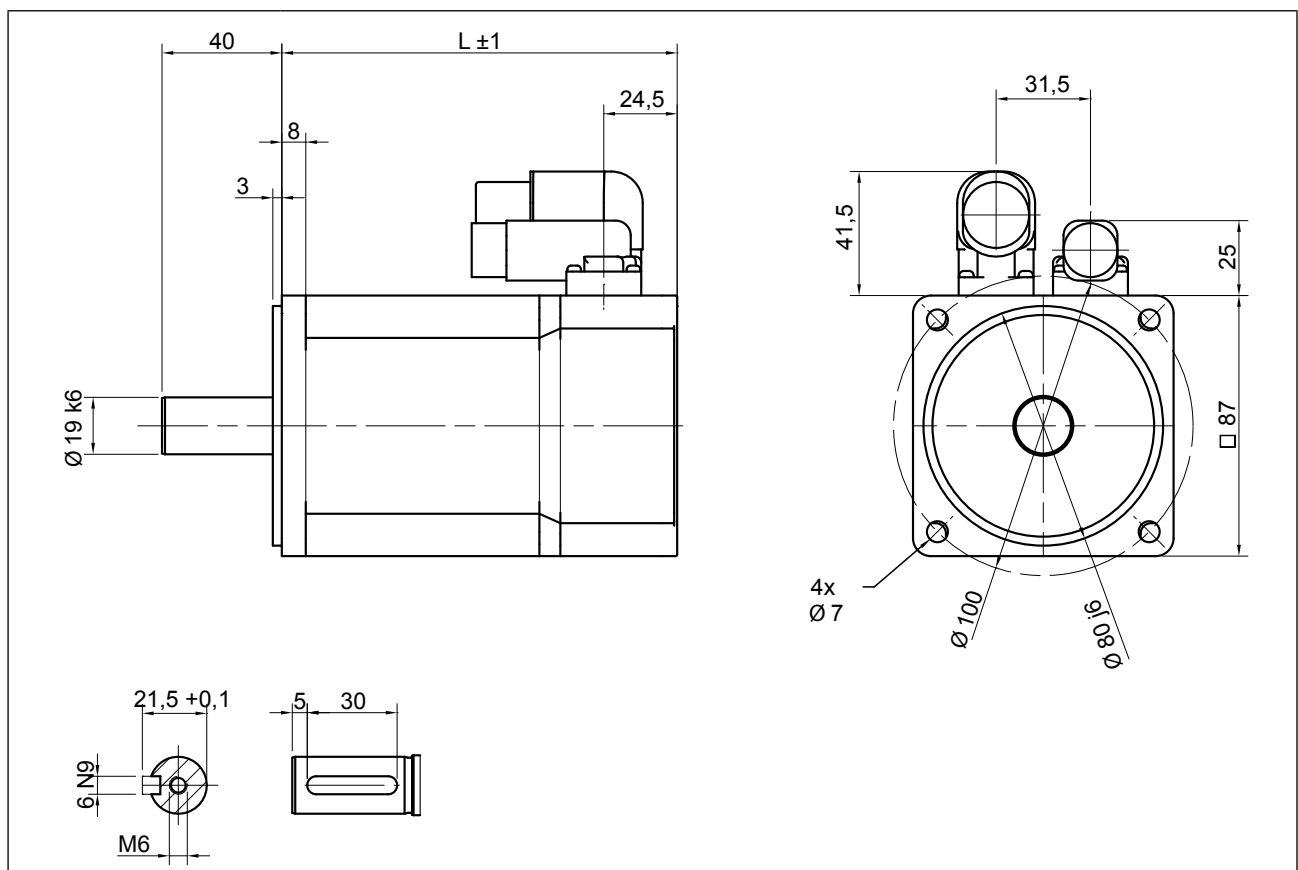

Motor type	Brake	L without holding brake	L with holding brake
	C1		132
C2		162	209.5
C3		192	239.5

All dimensions in mm.

Figure 18: Dimensions servo motors CxSMHFx-xxxx

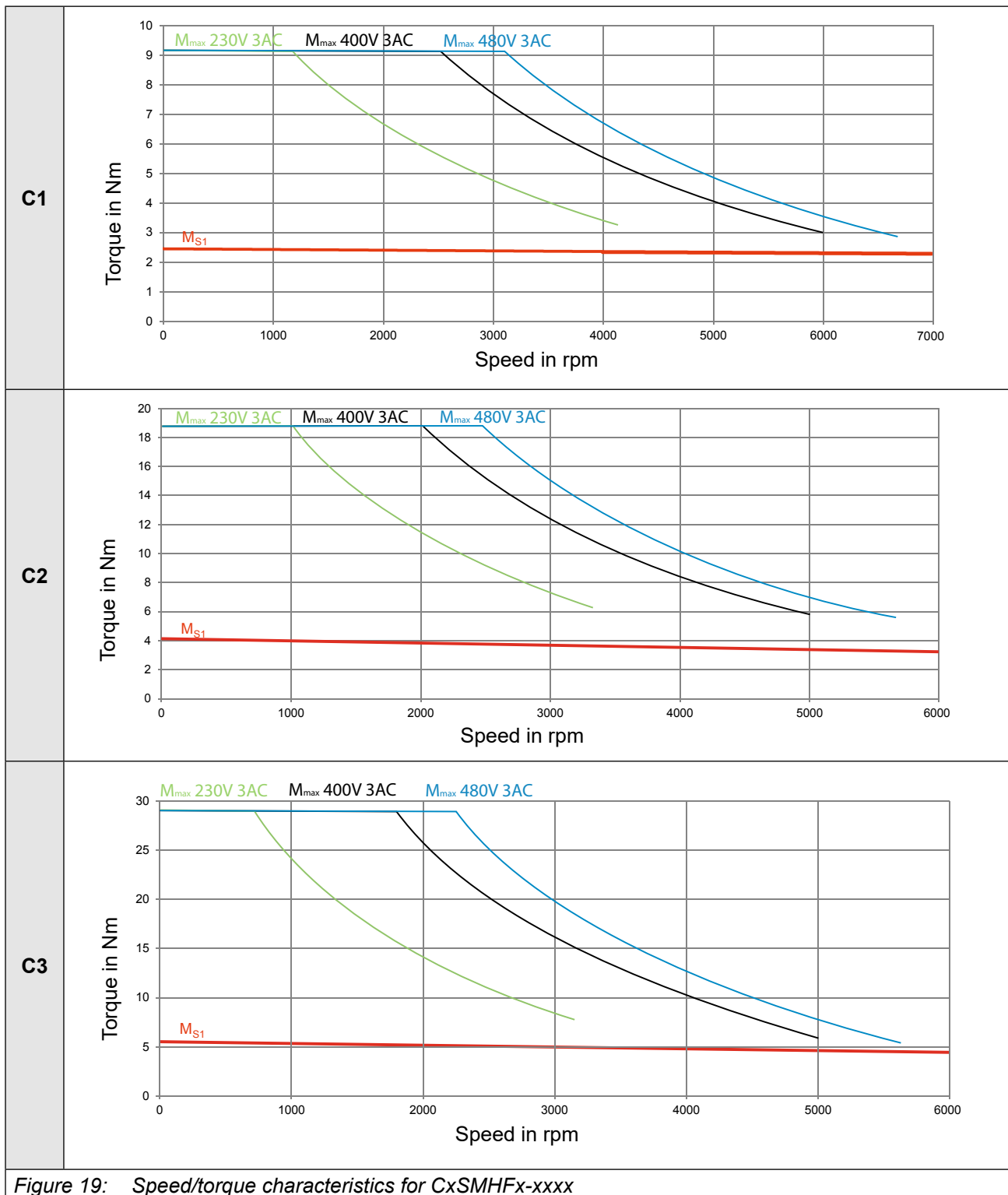

Figure 19: Speed/torque characteristics for CxSMHFx-xxxx

5.7 Technical data servo motors DxSMHFx-xxxx

Motor type		D1	D2	D3
Stall torque	M_0 / Nm	4.9	8.2	11.4
Current at stall torque	I_0 / A	4.75	6.3	8.8
Rated current	I_N / A	4.2	5.2	6.3
Max. torque	M_{max} / Nm	17.76	35.34	53.13
Max. current	I_{max} / A	20.9	33.6	50.9
Max. speed <i>Mech</i>	n_{max} / rpm	9000		
Winding resistance	¹⁾ R_{u-v} / Ω	3.6	2.3	1.4
Winding inductance	¹⁾ L_{u-v} / mH	18.8	14.1	8.8
Voltage constant	¹⁾ $k_e / \text{Vpk}/1000 \text{ rpm}$	103.24	125.87	125.87
Inertia	²⁾ J_L / kgcm^2	2.23	4.06	5.88
Mass	²⁾ m / kg	4.1	5.7	7.4
Number of pole pairs	p	4		

Table 19: Technical data servo motors DxSMHFx-xxxx

- ¹⁾ From phase to phase at 20°C.
- ²⁾ With encoder connection, without holding brake.

Motor type		D1	D2	D3
Rated voltage	U_N / V	230		
Rated speed	n_N / rpm	2700	2200	
Rated motor frequency	f / Hz	180	145	
Rated torque	M_N / Nm	4.65	7.5	9.9
Rated power	P_N / kW	1.32	1.73	2.28
Rated voltage	U_N / V	400		
Rated speed	n_N / rpm	5000	4000	
Rated motor frequency	f / Hz	333	267	
Rated torque	M_N / Nm	4.4	6.9	8.35
Rated power	P_N / kW	2.3	2.89	3.5
Rated voltage	U_N / V	480		
Rated speed	n_N / rpm	5700	4500	
Rated motor frequency	f / Hz	380	300	
Rated torque	M_N / Nm	4.3	6.7	7.85
Rated power	P_N / kW	2.57	3.16	3.70

Table 20: Rated voltage-dependent technical data servo motors DxSMHFx-xxxx

5.7.1 Technical data of the holding brake 06P1320-1247 and 06P1320-1257

Holding brake		06P1320-1247		06P1320-1257
Motor type		D1	D2	D3
Holding torque at 120°C	M_{Br} / Nm	9		13
Rated voltage	U_{Br_dc} / V	24		
Power input at 24V	P_{Br} / W	18		17
Brake release time	t_1 / ms	40		45
Brake closing time	t_2 / ms	20		20
Inertia	¹⁾ J_{Br} / kgcm^2	2.89	4.72	7
Mass	¹⁾ m / kg	4.9	6.6	8.4

Table 21: Technical data of the holding brake 06P1320-1247 and 06P1320-1257

¹⁾ For the motor and the holding brake.



The values for parameters co22 and co24 are provided with customer-specific data in the S6 series.

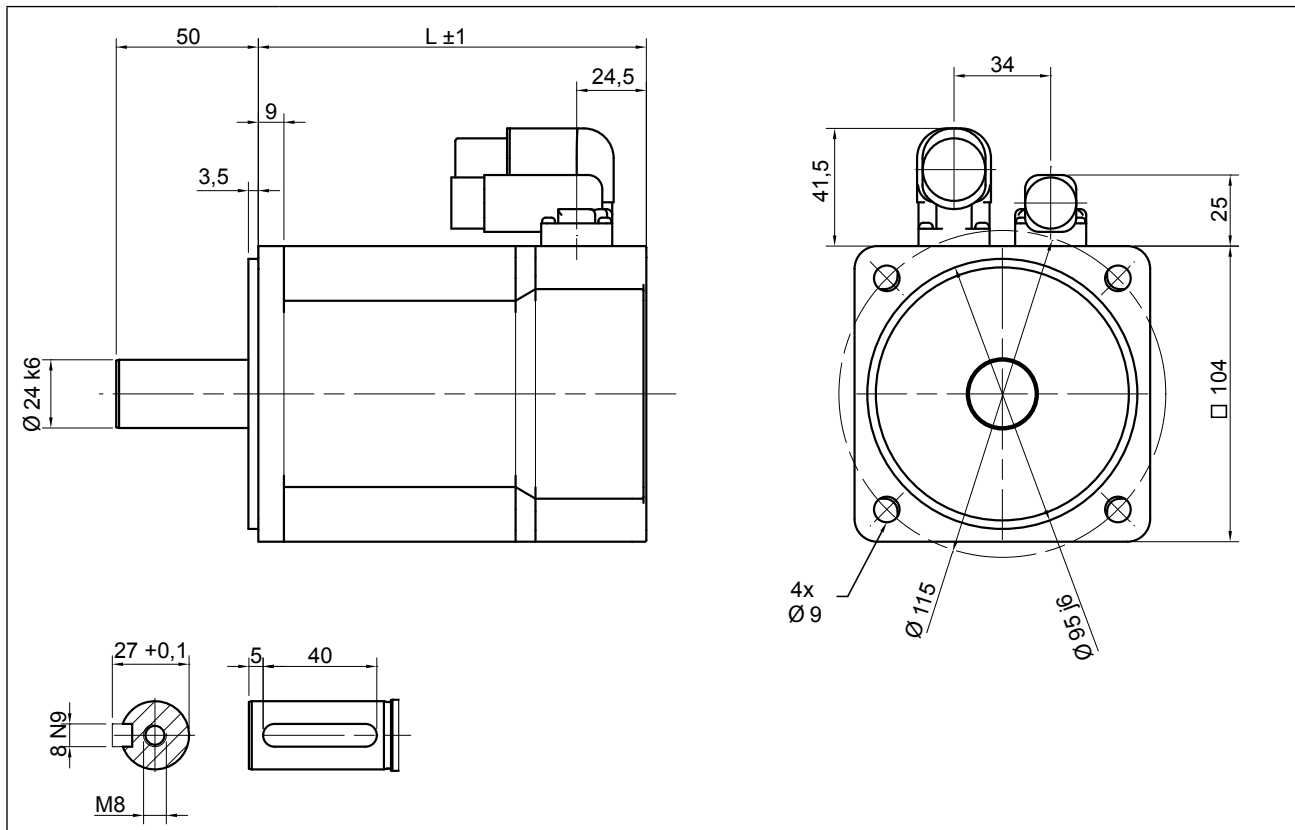

Motor type	Brake	L without holding brake	L with holding brake
	D1		136.5
D2		169.5	216.5
D3		202.5	251.5

All dimensions in mm.

Figure 20: Dimensions servo motors DxSMHFx-xxxx

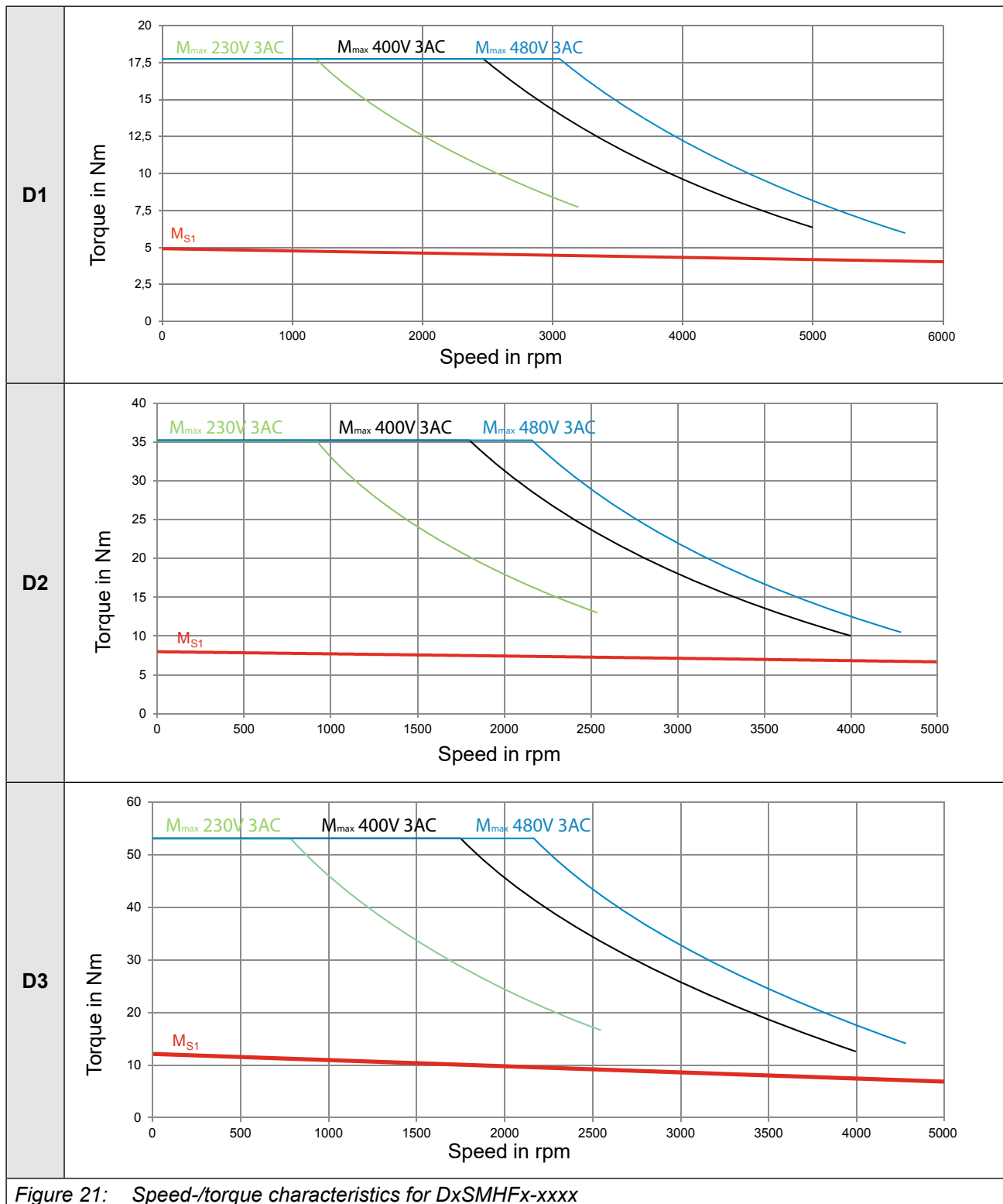

5.8 Technical data servo motors ExSMHFx-xxxx

Motor type		E1	E2	E3
Stall torque	M_0 / Nm	12.8	21.1	29
Current at stall torque	I_0 / A	7.8	12.4	17.2
Rated current	I_N / A	6.8	9.4	8.1
Max. torque	M_{max} / Nm	37.08	74.16	110.84
Max. current	I_{max} / A	27	54	80.9
Max. speed <i>Mech</i>	n_{max} / rpm	6000		
Winding resistance	¹⁾ R_{U-V} / Ω	1.9	0.75	0.45
Winding inductance	¹⁾ L_{U-V} / mH	13.9	6.6	4.2
Voltage constant	¹⁾ $k_e / \text{Vpk}/1000\text{rpm}$	162.6	165.46	164.05
Inertia	²⁾ J_L / kgcm^2	11.1	20	29
Mass	²⁾ m / kg	9.8	13.6	17.4
Number of pole pairs	p	5		

Table 22: Technical data servo motors ExSMHFx-xxxx

¹⁾ From phase to phase at 20°C.

²⁾ With encoder connection, without holding brake.

Motor type		E1	E2	E3
Rated voltage	U_N / V	230		
Rated speed	n_N / rpm	1600	1700	
Rated motor frequency	f / Hz	133	142	
Rated torque	M_N / Nm	12	18.2	21.1
Rated power	P_N / kW	2.01	3.24	3.76
Rated voltage	U_N / V	400		
Rated speed	n_N / rpm	3000		
Rated motor frequency	f / Hz	250		
Rated torque	M_N / Nm	11	15.2	13.2
Rated power	P_N / kW	3.46	4.78	4.15
Rated voltage	U_N / V	480		
Rated speed	n_N / rpm	3400		
Rated motor frequency	f / Hz	283		
Rated torque	M_N / Nm	10.4	13.9	11
Rated power	P_N / kW	3.7	4.95	3.91

Table 23: Rated voltage-dependent technical data servo motors ExSMHFx-xxxx

5.8.1 Technical data of the holding brake 07P1320-1147 and 08P1320-1097

Holding brake		07P1320-1147		08P1320-1097
Motor type		E1	E2	E3
Holding torque at 120°C	M_{Br} / Nm	20		36
Rated voltage	U_{Br_dc} / V	24		
Power input at 24V	P_{Br} / W	24		26
Brake release time	t_1 / ms	60		120
Brake closing time	t_2 / ms	40		45
Inertia	¹⁾ J_{Br} / kgcm^2	13.4	22.3	34.9
Mass	¹⁾ m / kg	11.6	15.4	20.1

Table 24: Technical data of the holding brake 07P1320-1147 and 08P1320-1097

¹⁾ For the motor and the holding brake.



The values for parameters co22 and co24 are provided with customer-specific data in the S6 series.

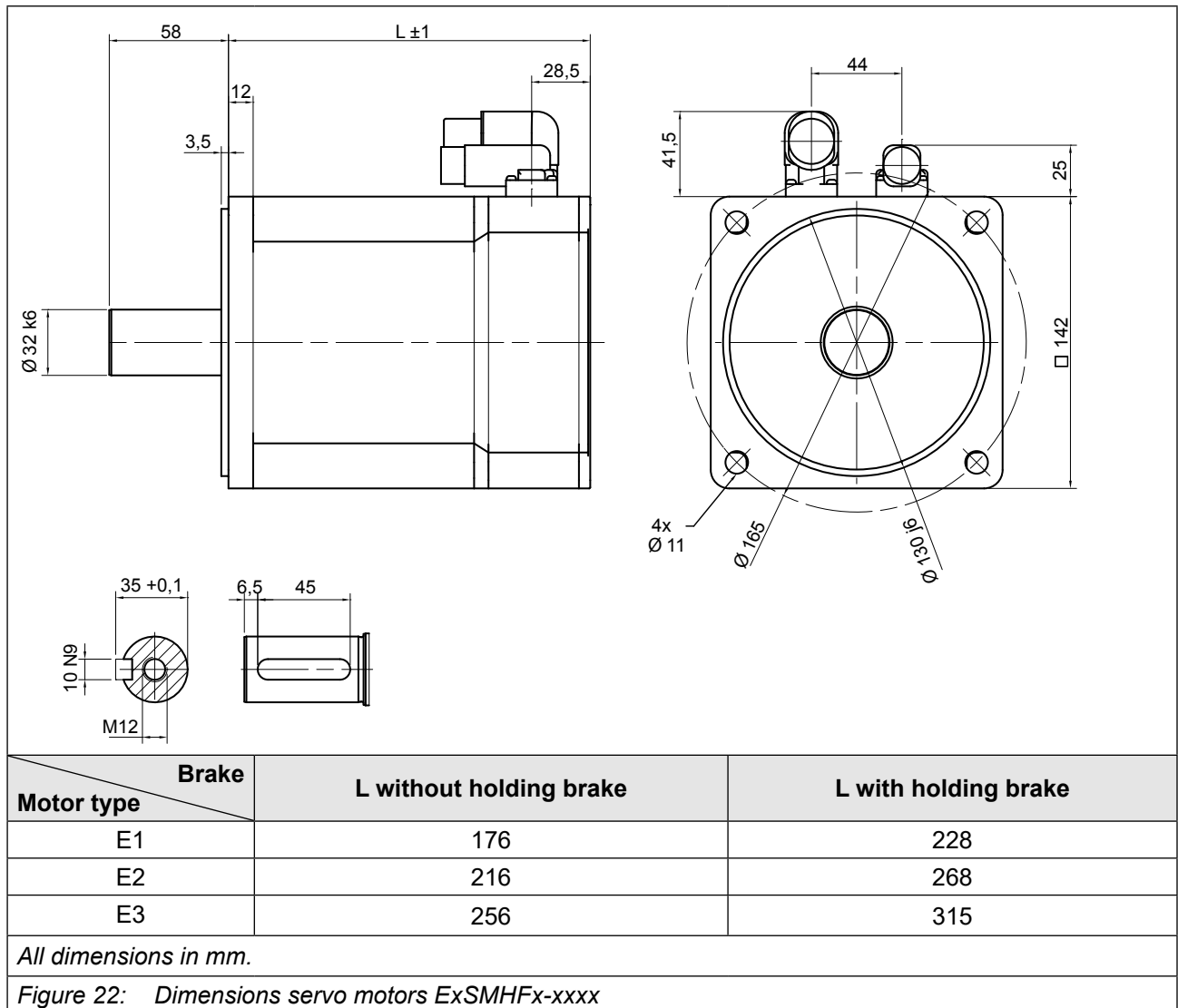

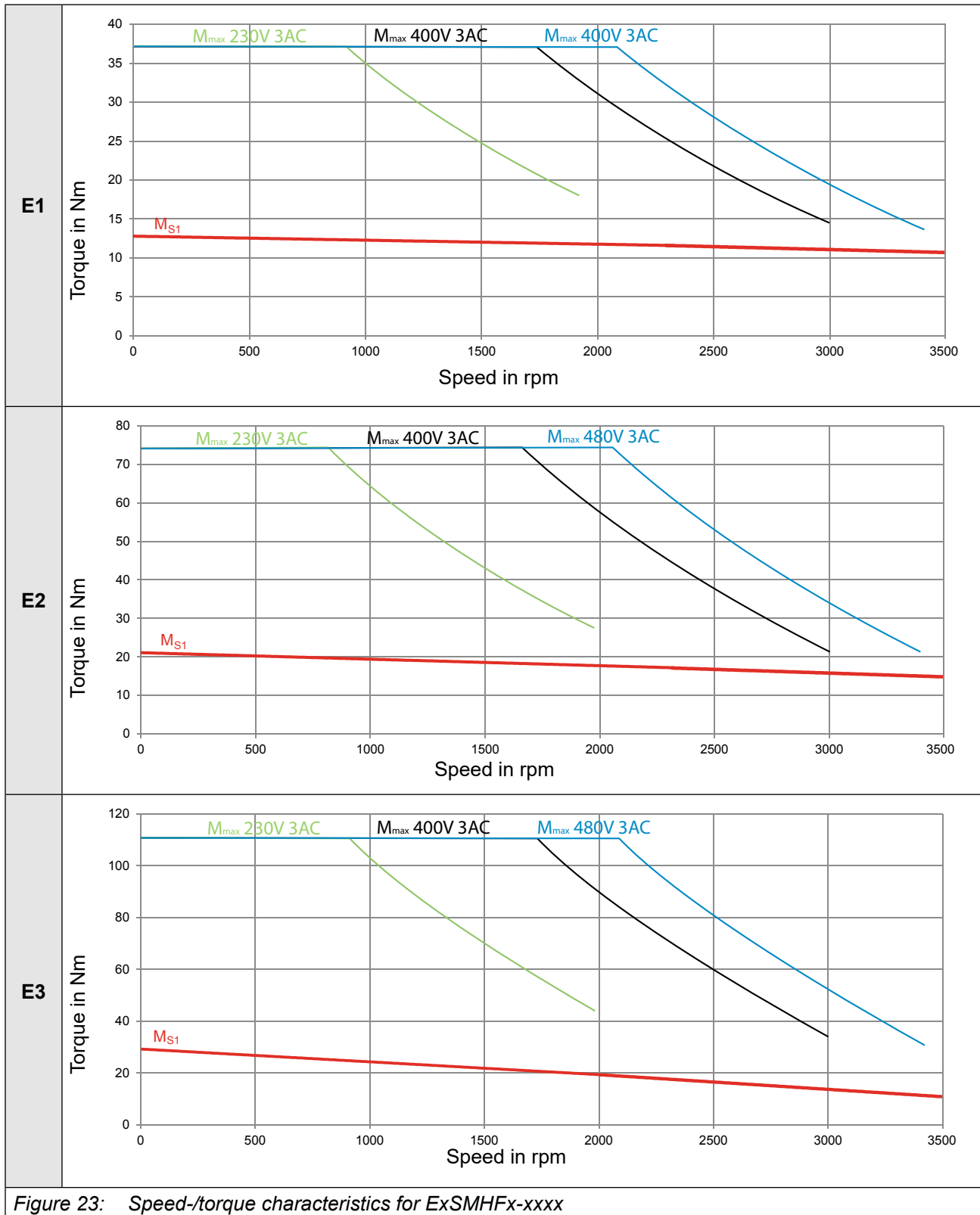

5.9 Technical data servo motors FxSMHFx-xxxx

Motor type		F1	F2	F3
Stall torque	M_0 / Nm	31.8	54.6	72.6
Current at stall torque	I_0 / A	17.8	20.6	27.9
Rated current	I_N / A	11.6	15.3	15.8
Max. torque	M_{max} / Nm	79.81	172.49	275.32
Max. current	I_{max} / A	49	66.1	97.4
Max. speed <i>Mech</i>	n_{max} / rpm	5000		
Winding resistance	¹⁾ R_{u-v} / Ω	0.45	0.39	0.25
Winding inductance	¹⁾ L_{u-v} / mH	7.8	7.7	4.9
Voltage constant	¹⁾ k_e / V _{pk} /1000rpm	172.53	254.56	258.8
Inertia	²⁾ J_L / kgcm ²	49.6	92.3	134.9
Mass	²⁾ m / kg	23.8	33.2	44.8
Number of pole pairs	p	5		

Table 25: Technical data servo motors FxSMHFx-xxxx

¹⁾ From phase to phase at 20°C.

²⁾ With encoder connection, without holding brake.

Motor type		F1	F2	F3
Rated voltage	U_N / V	230		
Rated speed	n_N / rpm	1500	1000	
Rated motor frequency	f / Hz	125	83	
Rated torque	M_N / Nm	26.4	48.9	58.5
Rated power	P_N / kW	4.15	5.12	6,3
Rated voltage	U_N / V	400		
Rated speed	n_N / rpm	3000	2000	
Rated motor frequency	f / Hz	250	167	
Rated torque	M_N / Nm	19.5	38.2	38.8
Rated power	P_N / kW	6.13	8	8.13
Rated voltage	U_N / V	480		
Rated speed	n_N / rpm	3300	2200	
Rated motor frequency	f / Hz	275	183	
Rated torque	M_N / Nm	18.2	35.9	35.4
Rated power	P_N / kW	6.29	8.27	8.16

Table 26: Rated voltage-dependent technical data servo motors FxSMHFx-xxxx

5.9.1 Technical data of the holding brake 09P1320-0617

Holding brake		09P1320-0617		
Motor type		F1	F2	F3
Holding torque at 120°C	M_{Br} / Nm	70		
Rated voltage	U_{Br_dc} / V	24		
Power input at 24V	P_{Br} / W	40		
Brake release time	t_1 / ms	200		
Brake closing time	t_2 / ms	50		
Inertia	¹⁾ J_{Br} / kgcm^2	68.3	110.9	153.6
Mass	¹⁾ m / kg	29.3	38.7	50.3

Table 27: Technical data of the holding brake 09P1320-0617

¹⁾ For the motor and the holding brake.



The values for parameters co22 and co24 are provided with customer-specific data in the S6 series.

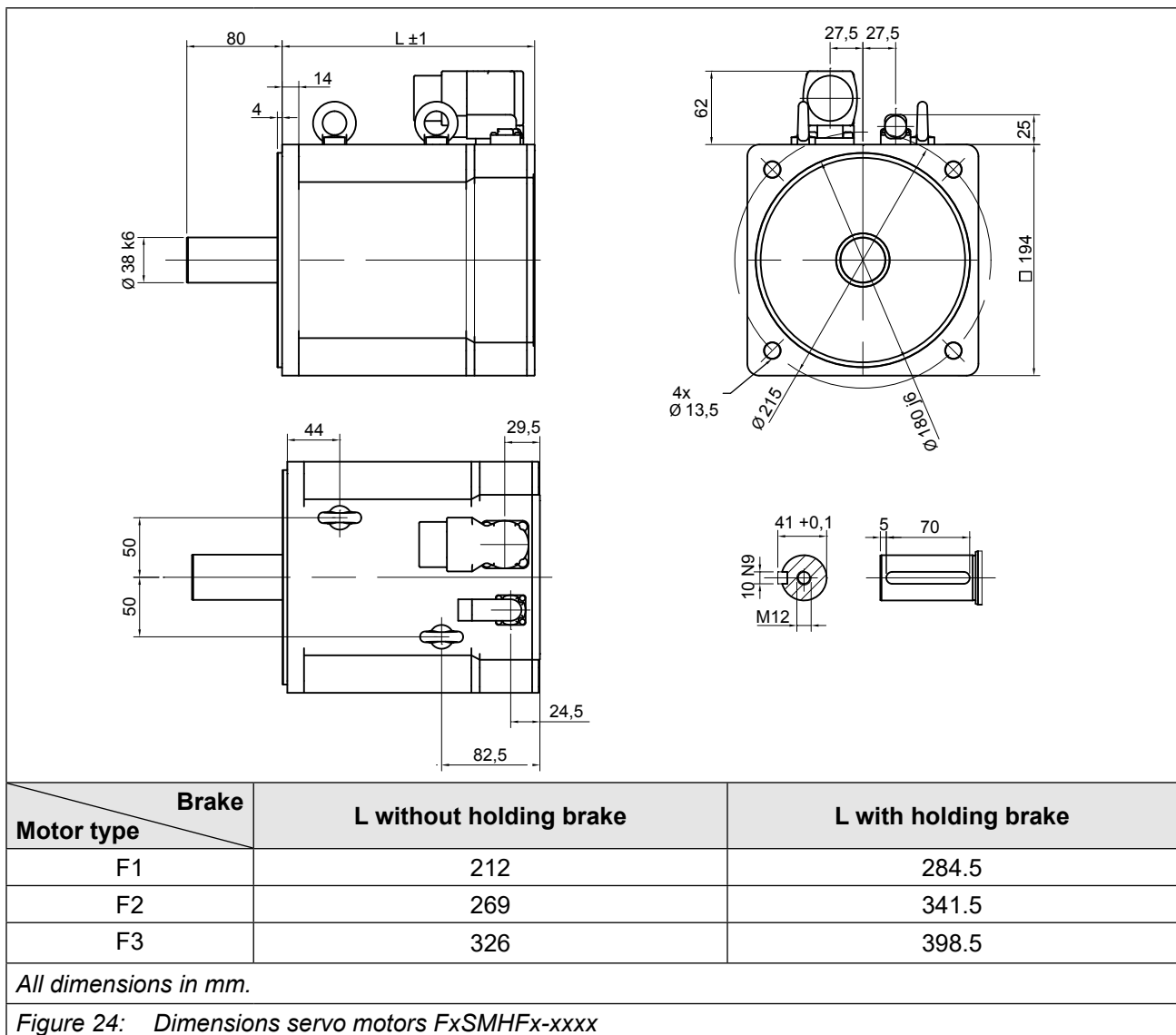

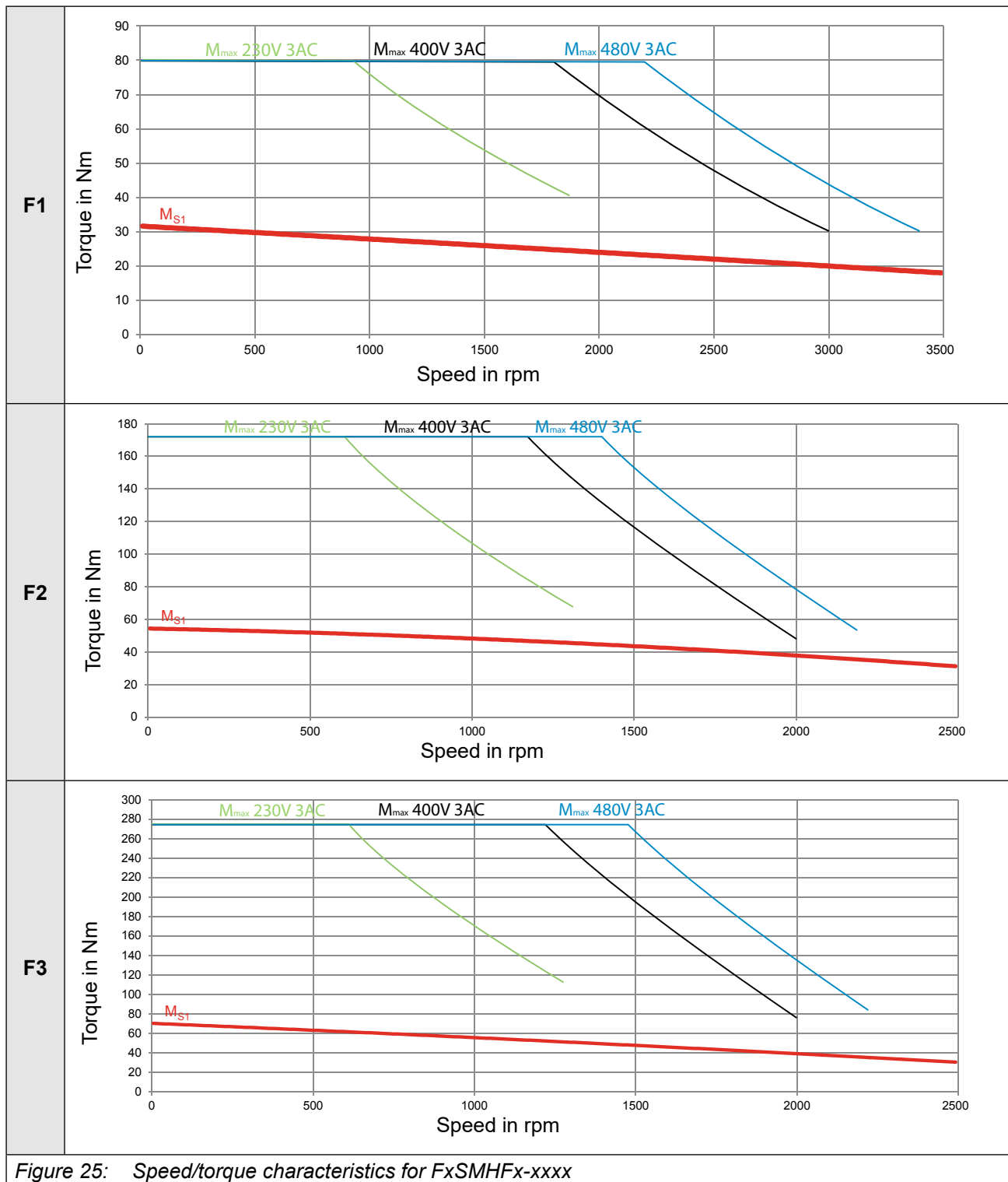

Figure 25: Speed/torque characteristics for FxSMHFx-xxxx

6 Certification

6.1 Certification

6.1.1 CE-Marking

CE marked servo motors were developed and manufactured to comply with the regulations of the Low-Voltage Directive and the EMC Directive. The harmonized standards of the series *EN 61800-5-1* and *EN 61800-3* were used.

This is a product of limited availability in accordance with *EN 61800-3*. This product may cause radio interference in residential areas. In this case the operator may need to take corresponding measures.

6.1.2 UL certification

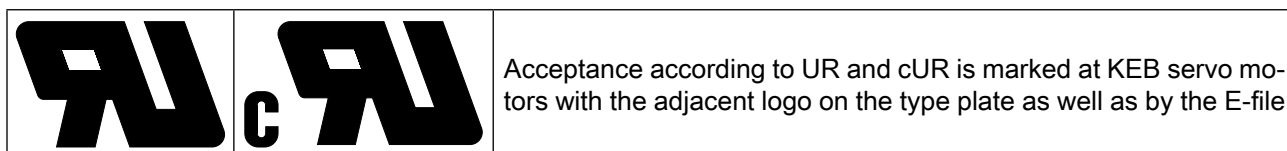

6.2 Further information and documentation

Supplementary manuals and information to the download can be found at www.keb.de/de/service/downloads

General manuals

- EMC and safety instructions
- Manuals for additional control boards, safety modules, fieldbus modules, etc.

Manuals for construction and development

- Input fuses in accordance with UL
- Programming manual for control and power unit
- Motor configurator, to select the correct drive controller and to create downloads for parameterizing the drive controller

Approvals and approbations

- CE declaration of conformity
- TÜV certificate
- FS certification

Other

- COMBIVIS, the software for comfortable parameterization of drive controllers via a PC (available for download)
- EPLAN drawings

Austria | KEB Automation GmbH
Ritzstraße 8 4614 Marchtrenk Austria
Tel: +43 7243 53586-0 Fax: +43 7243 53586-21
E-Mail: info@keb.at Internet: www.keb.at

Benelux | KEB Automation KG
Dreef 4 - box 4 1703 Dilbeek Belgium
Tel: +32 2 447 8580
E-Mail: info.benelux@keb.de Internet: www.keb.de

Brazil | KEB South America - Regional Manager
Rua Dr. Omar Pacheco Souza Riberio, 70
CEP 13569-430 Portal do Sol, São Carlos Brazil
Tel: +55 16 31161294 E-Mail: roberto.arias@keb.de

Czech Republic | KEB Automation GmbH
Videnska 188/119d 61900 Brno Czech Republic
Tel: +420 544 212 008
E-Mail: info@keb.cz Internet: www.keb.cz

France | Société Française KEB SASU
Z.I. de la Croix St. Nicolas 14, rue Gustave Eiffel
94510 La Queue en Brie France
Tel: +33 149620101 Fax: +33 145767495
E-Mail: info@keb.fr Internet: www.keb.fr

Germany | Gearing Motors
KEB Antriebstechnik GmbH
Wildbacher Straße 5 08289 Schneeberg Germany
Telefon +49 3772 67-0 Telefax +49 3772 67-281
Internet: www.keb-drive.de E-Mail: info@keb-drive.de

Italy | KEB Italia S.r.l. Unipersonale
Via Newton, 2 20019 Settimo Milanese (Milano) Italia
Tel: +39 02 3353531 Fax: +39 02 33500790
E-Mail: info@keb.it Internet: www.keb.it

Japan | KEB Japan Ltd.
15 - 16, 2 - Chome, Takanawa Minato-ku Tokyo 108 - 0074 Japan
Tel: +81 33 445-8515 Fax: +81 33 445-8215
E-Mail: info@keb.jp Internet: www.keb.jp

P. R. China | KEB Power Transmission Technology (Shanghai) Co. Ltd.
No. 435 QianPu Road Chedun Town Songjiang District
201611 Shanghai P.R. China
Tel: +86 21 37746688 Fax: +86 21 37746600
E-Mail: info@keb.cn Internet: www.keb.cn

Poland | KEB Automation KG
Tel: +48 60407727
E-Mail: roman.trinczek@keb.de Internet: www.keb.de

Republic of Korea | KEB Automation KG
Deoksan-Besttel 1132 ho Sangnam-ro 37
Seongsan-gu Changwon-si Gyeongsangnam-do Republic of Korea
Tel: +82 55 601 5505 Fax: +82 55 601 5506
E-Mail: jaeok.kim@keb.de Internet: www.keb.de

Russian Federation | KEB RUS Ltd.
Lesnaya str, house 30 Dzerzhinsky MO
140091 Moscow region Russian Federation
Tel: +7 495 6320217 Fax: +7 495 6320217
E-Mail: info@keb.ru Internet: www.keb.ru

Spain | KEB Automation KG
c / Mitjer, Nave 8 - Pol. Ind. LA MASIA
08798 Sant Cugat Sesgarrigues (Barcelona) Spain
Tel: +34 93 8970268 Fax: +34 93 8992035 E-Mail: vb.espana@keb.de

Switzerland | KEB Automation AG
Witzbergstrasse 24 8330 Pfaeffikon/ZH Switzerland
Tel: +41 43 2886060 Fax: +41 43 2886088
E-Mail: info@keb.ch Internet: www.keb.ch

United Kingdom | KEB (UK) Ltd.
5 Morris Close Park Farm Industrial Estate
Wellingborough, Northants, NN8 6 XF United Kingdom
Tel: +44 1933 402220 Fax: +44 1933 400724
E-Mail: info@keb.co.uk Internet: www.keb.co.uk

United States | KEB America, Inc
5100 Valley Industrial Blvd. South
Shakopee, MN 55379 United States
Tel: +1 952 2241400 Fax: +1 952 2241499
E-Mail: info@kebamerica.com Internet: www.kebamerica.com



MORE KEB PARTNERS WORLDWIDE:

... www.keb.co.uk/contact/contact-worldwide



Automation with Drive

www.keb.de

KEB Automation KG Suedstrasse 38 32683 Barntrup Tel. +49 5263 401-0 E-Mail: info@keb.de