

# COMBIVERT F6

INSTRUCTIONS FOR USE | **INSTALLATION F6 HOUSING 9**  
**HIGH SPEED DRIVE**

Translation of the original manual  
Document 20319504 EN 04



# Preface

The hardware and software described in this document are products of KEB. The information contained in this document is valid at the time of publishing. KEB reserves the right to update this document in response to misprints, mistakes or technical changes.

## Signal words and symbols

Certain procedures within this document can cause safety hazards during the installation or operation of the device. Refer to the safety warnings in this document when performing these procedures. Safety signs are also located on the device where applicable. A safety warning is marked by one of the following warning signs:

<b>DANGER</b>	Dangerous situation, which will cause death or serious injury if this safety warning is ignored.
<b>WARNING</b>	Dangerous situation, which may cause death or serious injury if this safety warning is ignored.
<b>CAUTION</b>	Dangerous situation, which may cause minor injury if this safety warning is ignored.
<b>NOTICE</b>	Situation, which can cause damage to property if this safety warning is ignored.

### RESTRICTION

Used when the following statements depend on certain conditions or are only valid for certain ranges of values.



Used for informational messages or recommended procedures.

## More symbols

- ▶ This arrow starts an action step.
- / - Enumerations are marked with dots or indents.
- => Cross reference to another chapter or another page.



Note to further documentation.  
<https://www.keb-automation.com/search>



## Laws and guidelines

KEB Automation KG confirms with the EC declaration of conformity and the CE mark on the device nameplate that it complies with the essential safety requirements.

The EC declaration of conformity can be downloaded on demand via our website.

## Warranty and liability

The warranty and liability on design, material or workmanship for the acquired device is given in the general sales conditions.



Here you will find our general sales conditions.  
<https://www.keb-automation.com/terms-conditions>



Further agreements or specifications require a written confirmation.

## Support

Although multiple applications are referenced, not every case has been taking into account. If you require further information or if problems occur which are not referenced in the documentation, you can request the necessary information via the local KEB agency.

**The use of our units in the target products is outside of our control and therefore lies exclusively in the area of responsibility of the customer.**

The information contained in the technical documentation, as well as any user-specific advice in spoken and written and through tests, are made to best of our knowledge and information about the intended use. However, they are regarded as being only informal and changes are expressly reserved, in particular due to technical changes. This also applies to any violation of industrial property rights of a third-party. Selection of our units in view of their suitability for the intended use must be done generally by the user.

**Tests can only be done within the intended end use of the product (application) by the customer. They must be repeated, even if only parts of hardware, software or the unit adjustment are modified.**

## Copyright

The customer may use the instructions for use as well as further documents or parts from it for internal purposes. Copyrights are with KEB and remain valid in its entirety.

This KEB product or parts thereof may contain third-party software, including free and/or open source software. If applicable, the license terms of this software are contained in the instructions for use. The instructions for use are already available to you, can be downloaded free of charge from the KEB website or can be requested from the respective KEB contact person.

Other wordmarks or/and logos are trademarks (™) or registered trademarks (®) of their respective owners.

# Table of Contents

<b>Preface</b> .....	<b>3</b>
Signal words and symbols .....	3
More symbols.....	3
Laws and guidelines.....	4
Warranty and liability.....	4
Support .....	4
Copyright.....	4
<b>Table of Contents</b> .....	<b>5</b>
<b>List of Figures</b> .....	<b>9</b>
<b>List of Tables</b> .....	<b>10</b>
<b>Glossary</b> .....	<b>11</b>
<b>Standards for drive controllers</b> .....	<b>13</b>
Product standards that apply directly to the drive controller .....	13
Basic standards to which drive controller standards refer directly .....	13
Standards that are used in the environment of the drive controller.....	14
<b>1 Basic Safety Instructions</b> .....	<b>15</b>
<b>1.1 Target group</b> .....	<b>15</b>
<b>1.2 Transport, storage and proper use</b> .....	<b>15</b>
<b>1.3 Installation</b> .....	<b>16</b>
<b>1.4 Electrical connection</b> .....	<b>17</b>
1.4.1 EMC-compatible installation.....	18
1.4.2 Voltage test.....	18
1.4.3 Insulation measurement.....	18
<b>1.5 Start-up and operation</b> .....	<b>19</b>
<b>1.6 Maintenance</b> .....	<b>20</b>
<b>1.8 Repair</b> .....	<b>21</b>
<b>1.7 Disposal</b> .....	<b>21</b>
<b>2 Product Description</b> .....	<b>22</b>
<b>2.1 Specified application</b> .....	<b>22</b>
2.1.1 Residual risks .....	22
<b>2.2 Unintended use</b> .....	<b>22</b>
<b>2.3 Product features</b> .....	<b>23</b>
<b>2.4 Part code</b> .....	<b>24</b>
<b>2.5 Nameplate</b> .....	<b>26</b>
2.5.1 Configurable options .....	27
<b>3 Technical data</b> .....	<b>28</b>
<b>3.1 Operating conditions</b> .....	<b>28</b>
3.1.1 Climatic environmental conditions.....	28
3.1.2 Mechanical environmental conditions .....	29

3.1.3	Chemical / mechanical active substances.....	29
3.1.4	Electrical operating conditions.....	30
3.1.4.1	Device classification .....	30
3.1.4.2	Electromagnetic compatibility.....	30
<b>3.2</b>	<b>Device data of the High Speed Drive devices.....</b>	<b>31</b>
3.2.1	Overview of the High Speed Drive device data.....	31
3.2.2	Voltage and frequencies for 400V devices.....	32
3.2.2.1	Example of the calculation of the possible motor voltage: .....	33
3.2.3	Input and output currents / overload.....	33
3.2.3.1	Overload characteristic (OL) .....	34
3.2.3.2	Frequency-dependent maximum current (OL2).....	36
3.2.4	Power dissipation at rated operation.....	40
3.2.5	Fusing of the HSD devices.....	40
<b>3.3</b>	<b>General electrical data .....</b>	<b>41</b>
3.3.1	Switching frequency and temperature.....	41
3.3.1.1	Switching frequencies and temperatures for fluid coolers (water).....	41
3.3.2	DC link / braking transistor.....	42
3.3.2.1	DC link / braking transistor function.....	43
3.3.3	Sub-mounted braking resistors .....	43
3.3.4	Fan .....	44
3.3.4.1	Switching behaviour of the fans .....	45
3.3.4.2	Switching points of the fans.....	45
<b>4</b>	<b>Installation.....</b>	<b>46</b>
<b>4.1</b>	<b>Dimensions and weights .....</b>	<b>46</b>
4.1.1	Built-in version fluid cooler (water) High-Performance with aluminium heat sink.....	46
4.1.2	Push-through version fluid cooler (water) High-Performance with aluminium heat sink IP20, IP54-ready .....	47
<b>4.2</b>	<b>Control cabinet installation .....</b>	<b>48</b>
4.2.1	Control cabinet installation .....	48
4.2.1.1	Devices with transport bracket .....	48
4.2.2	Mounting instructions .....	49
4.2.3	Mounting distances .....	50
4.2.4	Installation of IP54-ready devices .....	51
4.2.5	Control cabinet ventilation.....	52
4.2.6	Airflow of the drive converter .....	52
<b>5</b>	<b>Installation and connection .....</b>	<b>53</b>
<b>5.1</b>	<b>Overview of the COMBIVERT F6.....</b>	<b>53</b>
<b>5.2</b>	<b>Connection of the power unit.....</b>	<b>56</b>
5.2.1	Connection of the voltage supply .....	56
5.2.1.1	Terminal block X1A for 400V devices .....	57
5.2.2	Protective earth and functional earth.....	58

5.2.2.1 Protective earth .....	58
5.2.2.2 Functional earthing.....	58
5.2.3 AC mains connection.....	59
5.2.3.1 AC supply 3-phase .....	59
5.2.3.2 Supply cable.....	59
5.2.4 DC connection.....	60
5.2.4.1 Terminal block X1A DC connection .....	60
5.2.5 Connection of the motor .....	61
5.2.5.1 Wiring of the motor .....	61
5.2.5.2 Terminal block X1A motor connection .....	62
5.2.5.3 Selection of the motor line.....	63
5.2.5.4 Motor cable length and conducted interferences at AC supply .....	63
5.2.5.5 Motor cable length for parallel operation of motors .....	64
5.2.5.6 Motor cable cross-section .....	64
5.2.5.7 Interconnection of the motor.....	64
5.2.5.8 Connection of the temperature monitoring and brake control (X1C).....	65
5.2.6 Connection and use of a braking resistor.....	67
5.2.6.1 Terminal block X1A connection braking resistor.....	68
5.2.6.2 Use of non-intrinsically safe braking resistors .....	69
<b>5.3 Accessories .....</b>	<b>70</b>
5.3.1 Filters and chokes .....	70
5.3.2 Seal for IP54-ready devices .....	70
5.3.3 Side-mounted braking resistors.....	70
<b>6 Operation of Liquid-Cooled Devices.....</b>	<b>71</b>
<b>6.1 Water-cooled devices.....</b>	<b>71</b>
6.1.1 Heat sink and operating pressure .....	71
6.1.2 Materials in the cooling circuit .....	71
6.1.3 Requirements for the coolant .....	72
6.1.4 Connection of the cooling system .....	74
6.1.5 Coolant temperature and moisture condensation .....	75
6.1.5.1 Condensation .....	75
6.1.5.2 Supply of temper coolant.....	75
6.1.6 Permissible volume flow with water cooling .....	76
6.1.7 Coolant heating .....	77
6.1.7.1 Coolant heating .....	77
6.1.8 Typical pressure drop of the heat sink.....	78

<b>7 Certification.....</b>	<b>79</b>
7.1 CE marking.....	79
7.2 UL certification .....	80
7.3 Further informations and documentation.....	82
<b>8 Revision history.....</b>	<b>83</b>



## List of Figures

Figure 1:	Nameplate.....	26
Figure 2:	Configurable options .....	27
Figure 3:	Switch-off time $t$ depending on the overload I/IN (OL).....	35
Figure 4:	Typical overload characteristic in the lower output frequencies (OL2) Example 30 device.....	37
Figure 5:	Block diagram of the energy flow.....	42
Figure 6:	Switching behaviour of the fans example interior fan .....	45
Figure 7:	Dimensions built-in version fluid cooler (water) High-Performance .....	46
Figure 8:	Dimensions push-through version fluid cooler (water) High-Performance IP20, IP54-ready .....	47
Figure 9:	Example of an F6 in housing 8 with M10 ring bolts .....	48
Figure 10:	Example of an F6 housing 7 with transport brackets .....	48
Figure 11:	Mounting distances .....	50
Figure 12:	Installation of IP54-ready devices .....	51
Figure 13:	Control cabinet ventilation.....	52
Figure 14:	Airflow of the drive converter .....	52
Figure 15:	F6 housing 9 top view .....	53
Figure 16:	F6 housing 9 front view.....	54
Figure 17:	F6 housing 9 rear view with control board APPLICATION.....	55
Figure 18:	Input circuit.....	56
Figure 19:	Terminal block X1A for 400V devices .....	57
Figure 20:	Connection for protective earth.....	58
Figure 21:	Connection of the mains supply 3-phase.....	59
Figure 22:	Terminal block X1A DC connection.....	60
Figure 23:	Wiring of the motor.....	61
Figure 24:	Terminal block X1A motor connection.....	62
Figure 25:	Symmetrical motor line .....	63
Figure 26:	Terminal block X1C for control board APPLICATION and COMPACT.....	65
Figure 27:	Terminal block X1C for control board PRO .....	65
Figure 28:	Connection of the brake control.....	66
Figure 29:	Connection of a KTY sensor .....	66
Figure 30:	Terminal block X1A connection braking resistor .....	68
Figure 31:	Open pipe ends for the connection of the cooling system .....	74
Figure 32:	Volume flow depending on the total power dissipation $P_{D\_tot}$ and temperature difference with water-glycol mixture.....	77
Figure 33:	Typical pressure drop depending on the volume flow.....	78

## List of Tables

Table 1:	Part code.....	25
Table 2:	Climatic environmental conditions .....	28
Table 3:	Mechanical environmental conditions .....	29
Table 4:	Chemical / mechanical active substances .....	29
Table 5:	Device classification.....	30
Table 6:	Electromagnetic compatibility .....	30
Table 7:	Overview of the HSD device data .....	32
Table 8:	Input voltages and frequencies of the 400V devices .....	32
Table 9:	DC link voltage for 400V devices .....	32
Table 10:	Output voltages and frequencies of the 400V devices .....	33
Table 11:	Example of the calculation of the possible motor voltage:.....	33
Table 12:	Input currents of the HSD devices .....	33
Table 13:	Output currents and overload of the HSD devices.....	33
Table 14:	Frequency-dependent maximum current for device size 30 HSD (fluid cooler water).....	38
Table 15:	Frequency-dependent maximum current for device size 31 HSD (fluid cooler water).....	38
Table 16:	Frequency-dependent maximum current for device size 32 HSD (fluid cooler water).....	39
Table 17:	Frequency-dependent maximum current for device size 33 HSD (fluid cooler water).....	39
Table 18:	Power dissipation of the HSD devices .....	40
Table 19:	Fusing of the HSD devices .....	40
Table 20:	Switching frequency and temperature for HSD devices .....	41
Table 21:	DC link / braking transistor function of the HSD devices .....	43
Table 22:	Sub-mounted braking resistors .....	43
Table 23:	Fan.....	44
Table 24:	Switching points of the fans .....	45
Table 25:	Mounting instructions for built-in version.....	49
Table 26:	Mounting instructions for push-through version .....	49
Table 27:	Filters and chokes.....	70
Table 28:	Seal for IP54-ready devices.....	70
Table 29:	Electrochemical series / standard potentials against hydrogen.....	72
Table 30:	Requirements for the coolant.....	72
Table 31:	Special requirements for open and half-open cooling systems .....	73
Table 32:	Dew point table .....	75
Table 33:	Permissible volume flow with water cooling.....	76

## Glossary

0V	Earth-potential-free common point	Endat	Bidirectional encoder interface of the company Heidenhain
1ph	1-phase mains	EtherCAT	Real-time Ethernet bus system of the company Beckhoff
3ph	3-phase mains	Ethernet	Real-time bus system - defines protocols, plugs, types of cables
AC	AC current or voltage	FE	Functional earth
AFE	From 07/2019 AIC replaces the previous name AFE	FSoE	Functional Safety over Ethernet
AFE filter	From 07/2019 AIC filter replaces the previous name AFE filter	FU	Drive controller
AIC	Active Infeed Converter	GND	Reference potential, ground
AIC filter	Filter for Active Infeed Converter	GTR7	Braking transistor
Application	The application is the intended use of the KEB product	HF filter	High frequency filter to the mains
ASCL	Asynchronous sensorless closed loop	Hiperface	Bidirectional encoder interface of the company Sick-Stegmann
Auto motor ident.	Automatically motor identification; calibration of resistance and inductance	HMI	Human machine interface (touch screen)
AWG	American wire gauge	HSP5	Fast, serial protocol
B2B	Business-to-business	HTL	Incremental signal with an output voltage (up to 30V) -> TTL
BiSS	Open source real-time interface for sensors and actuators (DIN 5008)	IEC	International standard
CAN	Fieldbus system	IP xx	Degree of protection (xx for level)
c.d.f.	Cyclic duration factor	KEB product	The KEB product is subject of this manual
CDM	Complete drive module including auxiliary equipment (control cabinet)	KTY	Silicium temperature sensor (polarized)
COMBIVERT	KEB drive controller	Manufacturer	The manufacturer is KEB, unless otherwise specified (e.g. as manufacturer of machines, engines, vehicles or adhesives)
COMBIVIS	KEB start-up and parameterizing software	MCM	American unit for large wire cross sections
Customer	The customer has purchased a KEB product from KEB and integrates the KEB product into his product (customer product) or resells the KEB product (dealer)	Modulation	Means in drive technology that the power semiconductors are controlled
DC	DC current or voltage	MTTF	Mean service life to failure
DI	Demineralized water, also referred to as deionized (DI) water	NN	Sea level
DIN	German Institut for standardization	OC	Overcurrent
DS 402	CiA DS 402 - CAN device profile for drives	OH	Overheat
EMC	Electromagnetic compatibility	OL	Overload
Emergency stop	Shutdown of a drive in emergency case (not de-energized)	OSSD	Output signal swithcing device; - an output signal that is checked in regular intervals on its shutdown. (safety technology)
Emergency switching off	Switching off the voltage supply in emergency case	PDS	Power drive system incl. motor and measuring probe
EMS	Energy Management System	PE	Protective earth
EN	European standard	PELV	Protective Extra Low Voltage
Encoder emulation	Software-generated encoder output	PFD	Term used in the safety technology (EN 61508-1...7) for the size of error probability
End customer	The end customer is the user of the customer product		

## GLOSSARY

PFH	Term used in the safety technology (EN 61508-1...7) for the size of error probability per hour
PLC	Programmable logic controller
Pt100	Temperature sensor with $R_0=100\Omega$
Pt1000	Temperature sensor with $R_0=1000\Omega$
PTC	PTC-resistor for temperature detection
PWM	Pulse width modulation
RJ45	Modular connector with 8 lines
SCL	Synchronous sensorless closed loop
SELV	Safety Extra Low Voltage (<60V)
SIL	The safety integrity level is a measure for quantifying the risk reduction. Term used in the safety technology (EN 61508 -1...7)
SS1	Safety function „Safe stop 1“ in accordance with IEC 61800-5-2
SSI	Synchronous serial interface for encoder
STO	Safety function „Safe Torque Off“ in accordance with IEC 61800-5-2
TTL	Incremental signal with an output voltage up to 5V
USB	Universal serial bus
VARAN	Real-time Ethernet bus system

## Standards for drive controllers

### Product standards that apply directly to the drive controller

EN61800-2	Adjustable speed electrical power drive systems - Part 2: General requirements - Rating specifications for low voltage adjustable frequency a.c. power drive systems (VDE 0160-102, IEC 61800-2)
EN61800-3	Speed-adjustable electrical drives. Part 3: EMC requirements and specific test methods (VDE 0160-103, IEC 61800-3)
EN61800-5-1	Adjustable speed electrical power drive systems - Part 5-1: Safety requirements - Electrical, thermal and energy (IEC 61800-5-1); German version EN 61800-5-1
EN61800-5-2	Adjustable speed electrical power drive systems - Part 5-2: Safety Requirements - Functional (IEC 22G/264/CD)
UL61800-5-1	American version of the EN61800-5-1 with „National Deviations“

### Basic standards to which drive controller standards refer directly

EN 55011	Industrial, scientific and medical equipment - Radio frequency disturbance characteristics - Limits and methods of measurement (CISPR 11); German version EN 55011
EN 55021	Interference to mobile radiocommunications in the presence of impulse noise - Methods of judging degradation and measures to improve performance (IEC/ CISPR/D/230/FDIS); German version prEN 55021
EN 60529	Degrees of protection provided by enclosures (IP Code) (IEC 60529)
EN 60664-1	Insulation coordination for equipment within low-voltage systems Part 1: Principles, requirements and tests (IEC 60664-1)
EN 60721-3-1	Classification of environmental conditions - Part 3-1: Classification of groups of environmental parameters and their severities - Section 1: Storage (IEC 60721-3-1); German version EN 60721-3-1
EN 60721-3-2	Classification of environmental conditions - Part 3: Classification of groups of environmental parameters and their severities - Section 2: Transportation and handling (IEC 104/670/CD)
EN 60721-3-3	Classification of environmental conditions - Part 3: Classification of groups of environmental parameters and their severities; section 3: Stationary use at weatherprotected locations; Amendment A2 (IEC 60721-3-3); German version EN 60721-3-3   1994)
EN 61000-2-1	Electromagnetic compatibility (EMC) - Part 2: Environment - Section 1: Description of the environment - Electromagnetic environment for low-frequency conducted disturbances and signalling in public power supply systems
EN 61000-2-4	Electromagnetic compatibility (EMC) - Part 2-4: Environment; Compatibility levels in industrial plants for low-frequency conducted disturbances (IEC 61000-2-4); German version EN 61000-2-4
EN 61000-4-2	Electromagnetic compatibility (EMC) - Part 4-2: Testing and measurement techniques - Electrostatic discharge immunity test (IEC 61000-4-2); German version EN 61000-4-2
EN 61000-4-3	Electromagnetic compatibility (EMC) - Part 4-3: Testing and measurement techniques - Radiated, radio-frequency, electromagnetic field immunity test (IEC 61000-4-3); German version EN 61000-4-3
EN 61000-4-4	Electromagnetic compatibility (EMC) - Part 4-4: Testing and measurement techniques - Electrical fast transient/burst immunity test (IEC 61000-4-4); German version EN 61000-4-4

## STANDARDS FOR DRIVE CONTROLLERS

EN61000-4-5	Electromagnetic compatibility (EMC) - Part 4-5: Testing and measurement techniques - Surge immunity test (IEC 61000-4-5); German version EN 61000-4-5
EN61000-4-6	Electromagnetic compatibility (EMC) - Part 4-6: Testing and measurement techniques - Immunity to conducted disturbances, induced by radio-frequency fields (IEC 61000-4-6); German version EN 61000-4-6
EN61000-4-34	Electromagnetic compatibility (EMC) - Part 4-34: Testing and measurement techniques - Voltage dips, short interruptions and voltage variations immunity tests for equipment with mains current more than 16 A per phase (IEC 61000-4-34); German version EN 61000-4-34
EN61508-1...7	Functional safety of electrical/electronic/programmable electronic safety-related systems – Part 1...7 (VDE 0803-1...7, IEC 61508-1...7)
EN62061	Safety of machinery - functional safety of electrical, electronic and programmable electronic safety-related systems (VDE 0113-50, IEC 62061)
EN ISO 13849-1	Safety of machinery - safety-related parts of control systems - Part 1: General principles for design (ISO 13849-1); German version EN ISO 13849-1

### Standards that are used in the environment of the drive controller

DGUV regulation 3	Electrical installations and equipment
DIN IEC 60364-5-54	Low-voltage electrical installations - Part 5-54: Selection and erection of electrical equipment - Earthing arrangements, protective conductors and protective bonding conductors (IEC 64/1610/CD)
DIN VDE 0100-729	Low-voltage electrical installations - Part 7-729: Requirements for special installations or locations - Operating or maintenance gangways (IEC 60364-7-729:2007, modified); German implementation HD 60364-7-729:2009
DNVGL-CG-0339	Environmental test specification for electrical, electronic and programmable equipment and systems
EN 1037	Safety of machinery - Prevention of unexpected start-up; German version EN 1037
EN 12502-1...5	Protection of metallic materials against corrosion - Part 1...5
EN 60204-1	Safety of machinery - electrical equipment of machines Part 1: General requirements (VDE 0113-1, IEC 44/709/CDV)
EN 60439-1	Low-voltage switchgear and controlgear assemblies - Part 1: Type-tested and partially type-tested assemblies (IEC 60439-1); German version EN 60439-1
EN 60947-7-1	Low-voltage switchgear and controlgear - Part 7-1: Ancillary equipment - Terminal blocks for copper conductors (IEC 60947-7-1:2009); German version EN 60947-7-1:2009
EN 60947-8	Low-voltage switchgear and controlgear - Part 8: Control units for built-in thermal protection (PTC) for rotating electrical machines (IEC 60947-8:2003 + A1:2006 + A2:2011)
EN 61373	Railway applications - Rolling stock equipment - Shock and vibration tests (IEC 61373); German version EN 61373
EN 61439-1	Low-voltage switchgear and controlgear assemblies - Part 1: General rules (IEC 121B/40/CDV); German version FprEN 61439-1
VGB S 455 P	Water treatment and use of materials in cooling systems
DIN EN 60939-1	Passive filter units for electromagnetic interference suppression - Part 1: Generic specification (IEC 60939-1:2010); German version EN 60939-1:2010

# 1 Basic Safety Instructions

The products are designed and constructed in accordance with state-of-the-art technology and the recognized safety rules and regulations. However, the use of such devices may cause functional hazards for life and limb of the user or third parties, or damages to the system and other material property.

The following safety instructions have been created by the manufacturer for the area of electric drive technology. They can be supplemented by local, country- or application-specific safety instructions. This list is not exhaustive. Violation of the safety instructions by the customer, user or other third party leads to the loss of all resulting claims against the manufacturer.

## NOTICE



### Hazards and risks through ignorance!

- ▶ Read the instructions for use!
- ▶ Observe the safety and warning instructions!
- ▶ If anything is unclear, please contact KEB Automation KG!

## 1.1 Target group

This instruction manual is determined exclusively for electrical personnel. Electrical personnel for the purpose of this instruction manual must have the following qualifications:

- Knowledge and understanding of the safety instructions.
- Skills for installation and assembly.
- Start-up and operation of the product.
- Understanding of the function in the used machine.
- Detection of hazards and risks of the electrical drive technology.
- Knowledge of *DIN IEC 60364-5-54*.
- Knowledge of national safety regulations.

## 1.2 Transport, storage and proper use

The transport is carried out by qualified persons in accordance with the environmental conditions specified in this manual. Drive controller shall be protected against excessive strains.



### Transport of drive controllers with an edge length >75 cm

The transport by forklift without suitable tools can cause a deflection of the heat sink. This leads to premature aging or destruction of internal components.

- ▶ Transport of drive controllers on suitable pallets.
- ▶ Do not stack drive controllers or burden them with other heavy objects.

## NOTICE

### Damage to the coolant connections

#### Bending of the tubes!

- ▶ Never place the device on the coolant connections



---

**Drive controllers contain electrostatic sensitive components.**

- ▶ Avoid contact.
  - ▶ Wear ESD-protective clothing.
- 

Do not store drive controllers

- in the environment of aggressive and/or conductive liquids or gases.
- with direct sunlight.
- outside the specified environmental conditions.

### 1.3 Installation

**⚠ DANGER**



---

**Do not operate in an explosive environment!**

- ▶ The product is not intended for the use in potentially explosive environment.
- 

**⚠ CAUTION**



---

**Design-related edges and high weight!**

**Contusions and bruises!**

- ▶ Never stand under suspended loads.
  - ▶ Wear safety shoes.
  - ▶ Secure drive controller accordingly when using lifting gear.
- 

To prevent damages to the device:

- Make sure that no components are bent and/or isolation distances are changed.
- The device must not be put into operation in case of mechanical defects.
- Do not allow moisture or mist to penetrate the unit.
- Avoid dust permeating the device. Allow for sufficient heat dissipation if installed in a dust-proof housing.
- Note installation position and minimum distances to surrounding elements. Do not cover the ventilation openings.
- Mount the drive controller according to the specified degree of protection.
- Make sure that no small parts fall into the COMBIVERT during assembly and wiring (drilling chips, screws etc.). This also applies to mechanical components, which can lose small parts during operation.
- Check the reliable fit of the device connections in order to avoid contact resistances and sparking.
- Do not walk-on drive controller.
- Follow all safety instructions!



## 1.4 Electrical connection

### DANGER

#### Voltage at the terminals and in the device!

##### Danger to life due to electric shock !

- ▶ Never work on the open device or never touch exposed parts.
- ▶ For any work on the unit switch off the supply voltage, secure it against switching on and check absence of voltage by measuring at the input terminals.
- ▶ Wait until all drives has been stopped in order that no regenerative energy can be generated.
- ▶ Await capacitor discharge time (5 minutes). Check absence of voltage by measuring at the DC terminals.
- ▶ If personal protection is required, install suitable protective devices for drive converters.
- ▶ Never bridge upstream protective devices (even for testing purposes).
- ▶ Connect the protective earth conductor always to drive converter and motor.
- ▶ Install all required covers and protective devices for operation.
- ▶ The control cabinet shall be kept closed during operation.
- ▶ Residual current: This product may cause a dc current in the protective earth conductor. When a residual current protective device (RCD) or a residual current monitoring device (RCM) is used for the protection against direct or indirect contact, only a RCD or RCM type B is permitted on the power supply side of this product.
- ▶ Drive converters with a leakage current  $> 3.5\text{ mA AC}$  current (10 mA DC current) are intended for a stationary connection. Protective earth conductors must be designed in accordance with the local regulations for equipment with high leakage currents according to *EN 61800-5-1*, *EN 60204-1* or *DIN IEC 60364-5-54*.



If personnel protection is required during installation of the system, suitable protective devices must be used for drive controllers.

[www.keb.de/fileadmin/media/Techinfo/dr/tn/ti\\_dr\\_tn-rcd-00008\\_en.pdf](http://www.keb.de/fileadmin/media/Techinfo/dr/tn/ti_dr_tn-rcd-00008_en.pdf)



Installations which include drive controller shall be equipped with additional control and protective devices in accordance with the relevant applicable safety requirements, e.g. act respecting technical equipment, accident prevention rules etc. They must always be complied with, also for drive controller bearing a CE marking.

For a trouble-free and safe operation, please pay attention to the following instructions:

- The electrical installation shall be carried out in accordance with the relevant requirements.
- Cable cross-sections and fuses must be dimensioned by the user according to the specified minimum/maximum values for the application.
- The wiring must be made with flexible copper cable for a temperature > 75°C.
- Connection of the drive converter is only permissible on symmetrical networks with a maximum line voltage (L1, L2, L3) with respect to earth (N/PE) of max. 300V, USA UL: 480 / 277V. An isolating transformer must be used for supply networks which exceed this value! In case of non-compliance the control is not longer considered to be a PELV circuit.
- With existing or newly wired circuits the person installing the units or machines must ensure that the PELV requirements are met.
- For drive converters that are not isolated from the supply circuit (in accordance with [EN 60721-3-2](#)) all control lines must be included in other protective measures (e.g. double insulation or shielded, earthed and insulated).
- When using components without isolated inputs/outputs, it is necessary that equipotential bonding exists between the components to be connected (e.g. by the equipotential line). Disregard can cause destruction of the components by equalizing currents.

### 1.4.1 EMC-compatible installation

Observance of the limit values required by EMC law is the responsibility of the customer.



Notes on EMC-compatible installation can be found here.  
[www.keb.de/fileadmin/media/Manuals/dr/emv/0000neb0000.pdf](http://www.keb.de/fileadmin/media/Manuals/dr/emv/0000neb0000.pdf)



### 1.4.2 Voltage test

Testing with AC voltage (in accordance with [EN 60204-1](#) chapter 18.4) may not be executed, since there is danger for the power semiconductors in the drive controller.



Due to the radio interference suppression capacitors, the test generator will switch off immediately with a current fault.



According to [EN 60204-1](#) it is permissible to disconnect already tested components. Drive controllers of the KEB Automation KG are delivered ex works voltage tested to 100% according to product standard.

### 1.4.3 Insulation measurement

An insulation measurement (in accordance with [EN 60204-1](#) chapter 18.3) with DC 500V is permissible, if all power unit connections (grid-connected potential) and all control connections are bridged with PE. The insulation resistance of the respective device can be found in the technical data.

## 1.5 Start-up and operation

The start-up (i.e. for the specified application) is forbidden until it is determined that the installation complies with the machine directive; account is to be taken of [EN 60204-1](#).

### ⚠ WARNING

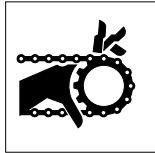

#### Software protection and programming!

##### Hazards caused by unintentional behavior of the drive!

- ▶ Check especially during initial start-up or replacement of the drive controller if parameterization is compatible to application.
- ▶ Securing a unit solely with software-supported functions is not sufficient. It is imperative to install external protective measures (e.g. limit switch) that are independent of the drive controller.
- ▶ Secure motors against automatic restart.

### ⚠ CAUTION



#### High temperatures at heat sink and coolant!

##### Burning of the skin!

- ▶ Cover hot surfaces safe-to-touch.
- ▶ If necessary, attach warning signs on the system.
- ▶ Before touching, check the surface and coolant lines.
- ▶ Before working let the unit cool down.

- During operation, all covers and doors shall be kept closed.
- Use only approved accessories for this device.
- Never touch terminals, busbars or cable ends.



If a drive controller with electrolytic capacitors in a DC link has not been in operation for more than one year, observe the following instructions.

[www.keb.de/fileadmin/media/Techinfo/dr/tn/ti\\_dr\\_tn-format-capacitors-00009\\_en.pdf](http://www.keb.de/fileadmin/media/Techinfo/dr/tn/ti_dr_tn-format-capacitors-00009_en.pdf)



### ⚠ CAUTION



#### High sound level during operation!

##### Hearing damage possible!

- ▶ Wear hearing protection!

### NOTICE

#### Continuous operation (S1) with load > 60% or from a rated motor power of 55 kW!

##### Premature ageing of the electrolytic capacitors!

- ▶ Mains choke with  $U_k = 4\%$  absolutely necessary.

### **Switching at the output**

Switching between motor and drive controller is prohibited for single drives during operation as this may trigger the protection gear of the device. Function ‚speed search‘ must be activated if switching can not be avoided. Speed search may only be triggered after closing the motor contactor (e.g. by switching the control release).

Connecting and disconnecting is permissible with multiple motor drives if at least 1 motor is running during the switch-over process. The drive controller must be dimensioned to the occurring starting currents.

The ‚speed search‘ function must be activated if the motor is still running during a restart of the drive controller (mains on) (e.g. due to large rotating masses).

### **Switching at the input**

For applications that require cyclic switching off and on of the drive controller, maintain an off-time of at least 5 min after the last switch on. If you require shorter cycle times please contact KEB Automation KG.

### **Short-circuit resistance**

The drive converters are conditional short-circuit proof. After resetting the internal protection devices, the function as directed is guaranteed.

Exceptions:

- If an earth-leakage fault or short-circuit often occurs at the output, this can lead to a defect in the unit.
- If a short-circuit occurs during regenerative operation (2nd or 4th quadrant, regeneration into the DC link), this can lead to a defect in the unit.

## **1.6 Maintenance**

The following maintenance work has to be carried out when required, but at least once per year by authorized and trained personnel. Check unit for loose screws and plugs and tighten if necessary.

- ▶ Check system for loose screws and plugs and tighten if necessary.
- ▶ Clean drive controller from dirt and dust deposits. Pay attention especially to cooling fins and protective grid of the fans.
- ▶ Examine and clean extracted air filter and cooling air filter of the control cabinet.
- ▶ Check the function of the fans of the drive controller. The fan must be replaced in case of audible vibrations or squeak.
- ▶ In the case of liquid-cooled drive controllers a visual test of the cooling circuit for leaks and corrosion must be carried out. The cooling circuit must be completely empty if a unit shall be switched off for a longer period. The cooling circuit must be blown out additionally with compressed air at temperatures below 0°C.

## 1.8 Repair

In case of malfunction, unusual noises or smells inform a person in charge!

### DANGER



#### Unauthorized exchange, repair and modifications!

##### Unpredictable malfunctions!

- ▶ The function of the drive controller is dependent on its parameterization. Never replace without knowledge of the application.
- ▶ Modification or repair is permitted only by KEB Automation KG authorized personnel.
- ▶ Only use original manufacturer parts.
- ▶ Infringement will annul the liability for resulting consequences.

In case of failure, please contact the machine manufacturer. Only the machine manufacturer knows the parameterisation of the used drive controller and can provide an appropriate replacement or induce the maintenance.

## 1.7 Disposal

Electronic devices of the KEB Automation KG are exclusively professional devices for further industrial processing (so-called B2B devices).

Manufacturers of B2B devices are obliged to take back and recycle devices manufactured after 14.08.2018. These devices may not be disposed at the collection centres of public sector disposal organisations.

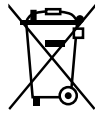

If no deviating agreement has been made between the customer and KEB or no deviating mandatory legal regulation exists, KEB products marked in this way can be returned. Company and keyword to the return point can be taken from the list below. Shipping costs are paid by the customer. Thereupon the devices will be professionally recycled and disposed.

The entry numbers are listed country-specific in the following table. The corresponding KEB return addresses can be found on our website.

Withdrawal by	WEEE-Reg.-No.	Keyword
<b>Austria</b>		
KEB Automation GmbH	ERA: 51976	Stichwort „Rücknahme WEEE“
<b>France</b>		
RÉCYLUM - Recycle point	ADEME: FR021806	Mots clés „KEB DEEE“
<b>Germany</b>		
KEB Automation KG	EAR: DE12653519	Stichwort „Rücknahme WEEE“
<b>Italy</b>		
COBAT	AEE: (IT) 1903000011216	Parola chiave „Ritiro RAEE“
<b>Spain</b>		
KEB Automation KG	RII-AEE 7427	Palabra clave „Retirada RAEE“
<b>Česko</b>		
KEB Automation KG	RETELA 09281/20 ECZ	Klíčové slovo: Zpětný odběr OEEZ
<b>Slowakei</b>		
KEB Automation KG	ASEKOL: RV22EEZ0000421	Klíčové slovo: "Spätný odběr OEEZ"

The packaging must be feed to paper and cardboard recycling.

## 2 Product Description

The device series COMBIVERT F6 concerns to drive controllers, which are optimized for operation at synchronous and asynchronous motors.

The COMBIVERT can be extended with a safety module for the use in safety-oriented applications. The COMBIVERT F6 series are drive converters with functional safety, optimized for operation at synchronous and asynchronous motors.

Various safety functions are available for different applications. It can be operated with a fieldbus module at different fieldbus systems. The control board has a system comprehensive operating concept.

The COMBIVERT complies with the requirements of the Machinery Directive. The possible functions are certified via a type test.

The COMBIVERT is a product of limited availability in accordance with [EN 61800-3](#). This product may cause radio interference in residential areas. In this case the operator may need to take corresponding measures.

The Machinery Directive, EMC Directive, Low Voltage Directive and other directives and regulations must be observed

### 2.1 Specified application

The COMBIVERT serves exclusively for the control and regulation of three-phase motors. It is intended for the installation into electrical systems or machines.

Technical data and information for connection conditions shall be taken from the nameplate and from the instructions for use and must be strictly observed.

The used semiconductors and components of the KEB Automation KG are developed and dimensioned for the use in industrial products.

#### **Restriction**

If the product is used in machines, which work under exceptional conditions or if essential functions, life-supporting measures or an extraordinary safety step must be fulfilled, the necessary reliability and security must be ensured by the machine builder.

#### 2.1.1 Residual risks

Despite intended use, the drive converter can reach unexpected operating conditions in case of error, with wrong parameterization, by faulty connection or unprofessional interventions and repairs. This can be:

- wrong direction of rotation
- motor speed too high
- motor is running into limitation
- motor can be under voltage even in standstill
- automatic start

### 2.2 Unintended use

The operation of other electric consumers is prohibited and can lead to the destruction of the devices. The operation of our products outside the indicated limit values of the technical data leads to the loss of any liability claims.

## 2.3 Product features

These instructions for use describe the power units of the following devices:

Device type:	Drive controller
Series:	COMBIVERT F6
Power range:	315...450 kW / 400 V
Housing:	9 High Speed Drive

The COMBIVERT F6 is characterized by the following features:

- Operation of three-phase asynchronous motors and three-phase synchronous motors, in operating modes open-loop or closed-loop with and without speed feedback
- Following fieldbus systems are supported:  
EtherCAT, VARAN, PROFINET, POWERLINK or CAN
- System-overlapping operating concept
- Wide operating temperature range
- Low switching losses by IGBT power unit
- Low noise development due to high switching frequencies
- Different heat sink concepts
- Temperature-controlled fan, easily replaceable
- Torque limits and s-curves are adjustable to protect gearboxes
- General protection functions of the COMBIVERT series against overcurrent, overvoltage, ground fault and overtemperature
- Analog inputs and outputs, digital inputs and outputs, relay output (potential-free), brake control and -supply, motor protection by I<sup>2</sup>t, KTY- or PTC input, two encoder interfaces, diagnostic interface, fieldbus interface (depending on the control board)
- Integrated safety function according to [EN 61800-5-2](#)

2.4 Part code

xx F6 xx-x-xx-xx

Heat sink version

1:	Air-cooler, mounted version
2:	Liquid cooler (water), mounted version
3:	Air-cooler, through-mount version IP54-ready
4:	Liquid cooler (water), through-mount version IP54-ready
5:	Air-cooler, through-mount version IP20
6:	Liquid cooler (water), trough-mount version IP54-ready, sub-mounted braking resistors
7:	Liquid cooler (oil), through-mount version IP54-ready
9:	Liquid cooler (water), mounted version, sub-mounted braking resistors
A:	Liquid cooler (water), mounted version, High Performance, sub-mounted braking resistors
B:	Liquid cooler (water), through-mount version, IP54-ready, High Performance, sub-mounted braking resistors
C:	Air-cooler, mounted version, Version 2
D:	Air-cooler, mounted version, High-Performance
E:	Liquid cooler (water), mounted version, High-Performance
F:	Air-cooler, through-mount version IP54-ready, High-Performance
G:	Liquid cooler (water), trough-mount version IP54-ready, High-Performance
H:	Air-cooler,, Convektion, trough-mount version IP54-ready

Control board variant

<b>APPLIKATION</b>	
1:	Multi Encoder Interface, CAN <sup>® 2)</sup> , Real-Time Ethernet-busmodule <sup>3)</sup>
B	Multi Encoder Interface, CAN <sup>® 2)</sup> , Real-Time Ethernet-busmodule <sup>3)</sup> , Alternative connector
<b>KOMPAKT</b>	
1:	Multi Encoder Interface, CAN <sup>® 2)</sup> , STO, EtherCAT <sup>® 1)</sup>
2:	Multi Encoder Interface, CAN <sup>® 2)</sup> , STO, VARAN
<b>PRO</b>	
0:	No Encoder, CAN <sup>® 2)</sup> , Real-Time Ethernetinterface <sup>3)</sup>
1:	Multi Encoder Interface, CAN <sup>® 2)</sup> , Real-Time Ethernet interface <sup>3)</sup>
3:	Multi Encoder Interface, CAN <sup>® 2)</sup> , Real-Time Ethernet interface <sup>3)</sup> , RS485-potential free
4:	No Encoder, CAN <sup>® 2)</sup> , Real-Time Ethernetinterface <sup>3)</sup> , safe relay
5:	Multi Encoder Interface, CAN <sup>® 2)</sup> , Real-Time Ethernet interface <sup>3)</sup> , safety relay
B:	Multi Encoder Interface, CAN <sup>® 2)</sup> , Real-Time Ethernet interface <sup>3)</sup> , alternative connector

*continued on the next page*



<b>x x</b>	<b>F 6</b>	<b>x</b>	<b>x</b>	<b>x</b>	<b>-x</b>	<b>x</b>	<b>x</b>	<b>x</b>
Switching frequency, Software current limit, Turn-off current						0: 2 kHz / 125% / 150%	8: 2 kHz / 180% / 216%	
						1: 4 kHz / 125% / 150%	9: 4 kHz / 180% / 216%	
						2: 8 kHz / 125% / 150%	A: 8 kHz / 180% / 216%	
						3: 16 kHz / 125% / 150%	B: 8 kHz / HSD	
						4: 2 kHz / 150% / 180%	C: 6 kHz / HSD	
						5: 4 kHz / 150% / 180%	Non standard switching	
						6: 8 kHz / 150% / 180%	D: frequency / Overload characteristic	
						7: 16 kHz / 150% / 180%	E: Special Device	
Voltage / Connection type						1: 3ph 230 V AC/DC with braking transistor		
						2: 3ph 230 V AC/DC without braking transistor		
						3: 3ph 400 V AC/DC with braking transistor		
						4: 3ph 400 V AC/DC without braking transistor		
						A: 3ph 400 V AC/DC incl. GTR7 / max. rectifier / max. pre-charging		
Housing						B: 3ph 400 V AC/DC without GTR7 / max. rectifier / max. pre-charging		
						C: 3ph 400 V AC/DC. GTR7-variant 2		
						D: 3ph 400 V AC/DC GTR7-variant 2 / max. rectifier / max. pre-charging		
						2...9		
Equipment						1: Safety module type 1 /STO at control type K		
						3: Safety module type 3		
						4: Safety module type 4		
						5: Safety module type 5		
Control type						A: APPLICATION		
						K: COMPACT		
						P: PRO		
Series						COMBIVERT F6		
Inverter size						10...33		

Table 1: Part code

- 1) EtherCAT® is registered trademark and patented technology, licensed by Beckhoff Automation GmbH, Germany
- 2) CANopen® is registered trademark of CAN in AUTOMATION - International Users and Manufacturers Group e.V.
- 3) The Real-Time Ethernetbusmodul / Real-Time Ethernet interface contains various fieldbus control types which can be adjusted by software (parameter fb68)



The part code may not be used as order code, but only for identification!

## 2.5 Nameplate

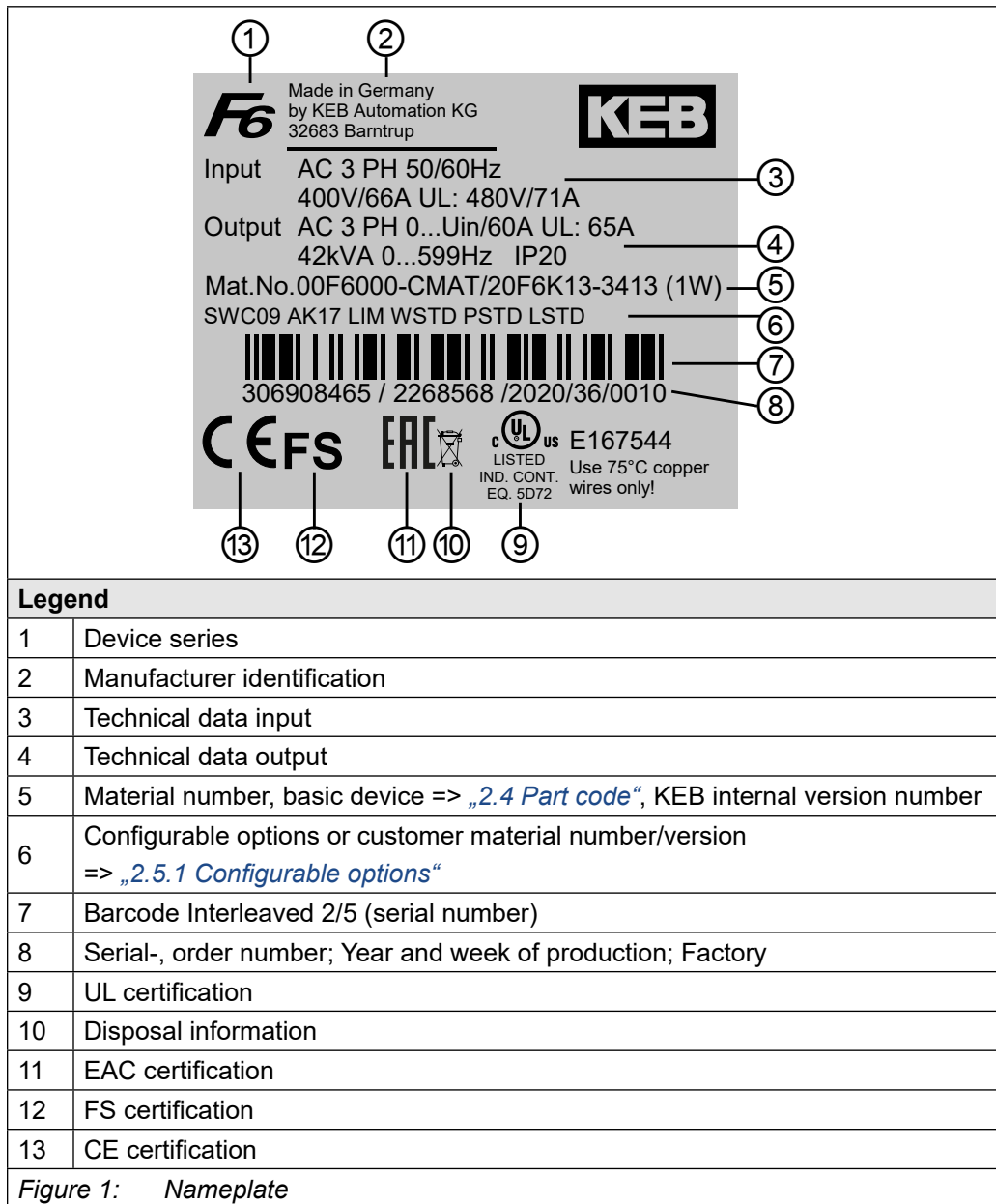

2.5.1 Configurable options

Features	Feature values	Description
Software	SWxxx <sup>1)</sup>	Software status of the drive converter
Accessories	Axxx <sup>1)</sup>	Selected accessories
	NAK	No accessories
Output frequency activation	LIM	Limitation to 599 Hz
	ULO	> 599 Hz activated
Warranty	WSTD	Warranty - Standard
	Wxxx <sup>1)</sup>	Warranty extension
Parameterization	PSTD	Parameterization - Standard
	Pxxx <sup>1)</sup>	Parameterization - Customer-specific
Nameplate logo	LSTD	Logo - Standard
	Lxxx <sup>1)</sup>	Logo - Customer-specific
<i>Figure 2: Configurable options</i>		

<sup>1)</sup> „x“ indicates a variable value

### 3 Technical data

Unless otherwise indicated, all electrical data in the following chapter refer to a 3-phase AC mains.

#### 3.1 Operating conditions

##### 3.1.1 Climatic environmental conditions

Storage		Standard	Class	Descriptions
Ambient temperature		EN 60721-3-1	1K4	-25...55 °C
Relative humidity		EN 60721-3-1	1K3	5...95 % (without condensation)
Storage height		–	–	Max. 3000 m above sea level
Transport		Standard	Class	Descriptions
Ambient temperature		EN 60721-3-2	2K3	-25...70 °C
Relative humidity		EN 60721-3-2	2K3	95 % at 40 °C (without condensation)
Operation		Standard	Class	Descriptions
Ambient temperature		EN 60721-3-3	3K3	5...40 °C (extended to -10...50 °C)
Coolant inlet temperature	Water <sup>1)</sup>	–	–	5...55 °C
Relative humidity		EN 60721-3-3	3K3	5...85 % (without condensation)
Version and degree of protection		EN 60529	IP20	Protection against foreign material > ø12.5 mm No protection against water Non-conductive pollution, occasional condensation when PDS is out of service. Drive controller generally, except power connections and fan unit (IPxxA)
Site altitude		–	–	Max. 2000 m above sea level • With site altitudes over 1000 m a derating of 1 % per 100 m must be taken into consideration. • With site altitudes over 2000 m, the control board to the mains has only basic isolation. Additional measures must be taken when wiring the control.

Table 2: Climatic environmental conditions

<sup>1)</sup> Observe the notes on the coolant => „6.1.3 Requirements for the coolant“

**3.1.2 Mechanical environmental conditions**

Storage		Standard	Class	Descriptions
Vibration limits		<a href="#">EN 60721-3-1</a>	1M2	Vibration amplitude 1.5 mm (2...9 Hz) Acceleration amplitude 5 m/s <sup>2</sup> (9...200 Hz)
Shock limit values		<a href="#">EN 60721-3-1</a>	1M2	40 m/s <sup>2</sup> ; 22 ms
Transport		Standard	Class	Descriptions
Vibration limits		<a href="#">EN 60721-3-2</a>	2M1	Vibration amplitude 3.5 mm (2...9 Hz) Acceleration amplitude 10 m/s <sup>2</sup> (9...200 Hz) (Acceleration amplitude 15 m/s <sup>2</sup> (200...500 Hz)) <sup>1)</sup>
Shock limit values		<a href="#">EN 60721-3-2</a>	2M1	100 m/s <sup>2</sup> ; 11 ms
Operation		Standard	Class	Descriptions
Vibration limits		<a href="#">EN 60721-3-3</a>	3M4	Vibration amplitude 3.0 mm (2...9 Hz) Acceleration amplitude 10 m/s <sup>2</sup> (9...200 Hz)
		<a href="#">EN 61800-5-1</a>	–	Vibration amplitude 0.075 mm (10...57 Hz) Acceleration amplitude 10 m/s <sup>2</sup> (57...150 Hz)
Shock limit values		<a href="#">EN 60721-3-3</a>	3M4	100 m/s <sup>2</sup> ; 11 ms
Pressure in the water cooler		–	–	Rated operating pressure: 10 bar Max. operating pressure: 10 bar

Table 3: Mechanical environmental conditions

<sup>1)</sup> Not tested.

**3.1.3 Chemical / mechanical active substances**

Storage		Standard	Class	Descriptions
Contamination	Gases	<a href="#">EN 60721-3-1</a>	1C2	–
	Solids		1S2	–
Transport		Standard	Class	Descriptions
Contamination	Gases	<a href="#">EN 60721-3-2</a>	2C2	–
	Solids		2S2	–
Operation		Standard	Class	Descriptions
Contamination	Gases	<a href="#">EN 60721-3-3</a>	3C2	–
	Solids		3S2	–

Table 4: Chemical / mechanical active substances

**3.1.4 Electrical operating conditions**

3.1.4.1 Device classification

Requirement	Standard	Class	Descriptions
Overtoltage category	<a href="#">EN 61800-5-1</a>	III	–
Pollution degree	<a href="#">EN 60664-1</a>	2	Non-conductive pollution, occasional condensation when PDS is out of service

Table 5: Device classification

3.1.4.2 Electromagnetic compatibility

For devices without an internal filter, an external filter is required to comply with the following limits.

EMC emitted interference	Standard	Class	Descriptions
Conducted interference emission	<a href="#">EN 61800-3</a>	C2 / C3	The specified value is only maintained in conjunction with a filter. Information on interference suppression (max. switching frequency, cable length) can be found in the corresponding filter instructions
Radiated emitted interference	<a href="#">EN 61800-3</a>	C2	–
Immunity	Standard	Level	Descriptions
Static discharges	<a href="#">EN 61000-4-2</a>	8 kV 4 kV	AD (air discharge) CD (contact discharge)
Burst - Ports for process measurement control lines and signal interfaces	<a href="#">EN 61000-4-4</a>	2 kV	–
Burst - AC - Power ports	<a href="#">EN 61000-4-4</a>	4 kV	–
Surge - Power ports	<a href="#">EN 61000-4-5</a>	1 kV 2 kV	Phase-phase Phase-ground
Conducted immunity, induced by high-frequency fields	<a href="#">EN 61000-4-6</a>	10 V	0.15...80 MHz
Electromagnetic fields	<a href="#">EN 61000-4-3</a>	10 V/m 3 V/m 1 V/m	80 MHz...1 GHz 1.4...2 GHz 2...2.7 GHz
Voltage fluctuations/ voltage dips	<a href="#">EN 61000-2-1</a> <a href="#">EN 61000-4-34</a>	–	-15 %...+10 % Class 3
Frequency changes	<a href="#">EN 61000-2-4</a>	–	≤ 2 %
Voltage deviations	<a href="#">EN 61000-2-4</a>	–	±10 %
Voltage unbalances	<a href="#">EN 61000-2-4</a>	–	≤ 3 %

Table 6: Electromagnetic compatibility

## 3.2 Device data of the High Speed Drive devices

### 3.2.1 Overview of the High Speed Drive device data

The technical data are for 2/4-pole standard motors. With other pole numbers the drive controller must be dimensioned onto the rated motor current. Contact KEB for special or medium frequency motors.

Device size		30	31	32	33
Housing		9			
Device type		High Speed Drive			
Rated apparent output power	$S_{out}$ / kVA	395	436	492	554
Max. rated motor power	<sup>1)</sup> $P_{mot}$ / kW	315	355	400	450
Rated input voltage	$U_N$ / V	400 (UL: 480)			
Input voltage range	$U_{in}$ / V	280...550			
Mains phases		3			
Mains frequency	$f_N$ / Hz	50 / 60 ±2			
Rated input current @ $U_N = 400V$	$I_{in}$ / A	600	660	746	840
Rated input current @ $U_N = 480V$	$I_{in\_UL}$ / A	513	575	646	726
Insulation resistance @ $U_{dc} = 500V$	$R_{iso}$ / MΩ	> 15			
Output voltage	$U_{out}$ / V	0... $U_{in}$			
Output frequency	<sup>2)</sup> $f_{out}$ / Hz	0...599 (0...2000)			
Output phases		3			
Rated output current @ $U_N = 400V$	$I_N$ / A	570	630	710	800
Rated output current @ $U_N = 480V$	$I_{N\_UL}$ / A	495	545	615	692
Rated output overload (60s)	<sup>3) 4)</sup> $I_{60s}$ / %	125	125	125	125
Software current limit	<sup>3)</sup> $I_{lim}$ / %	125	125	125	125
Overcurrent	<sup>3)</sup> $I_{OC}$ / %	150	150	150	150
Rated switching frequency	$f_{SN}$ / kHz	8	8	8	8
Max. switching frequency	<sup>5)</sup> $f_{S\_max}$ / kHz	8	8	8	8
Power dissipation at rated operation	<sup>1)</sup> $P_D$ / kW	8.05	9	10.5	12
Overload current over time	<sup>3)</sup> $I_{OL}$ / %	„3.2.3.1 Overload characteristic (OL)“			
Maximum current 0Hz/100Hz at $f_s = 2$ kHz	$I_{out\_max}$ / %	110 / 150	110 / 150	105 / 150	100 / 150
Maximum current 0Hz/100Hz at $f_s = 4$ kHz	$I_{out\_max}$ / %	101 / 150	95 / 150	85 / 150	75 / 150
Maximum current 0Hz/100Hz at $f_s = 8$ kHz	$I_{out\_max}$ / %	53 / 150	48 / 150	42 / 142	34 / 126
<i>continued on the next page</i>					

Device size	30	31	32	33
<b>Housing</b>	<b>9</b>			
Max. braking current	$I_{B\_max} / A$		600	
Min. braking resistor value	$R_{B\_min} / \Omega$		1.3	
Braking transistor	6)			
Protective function for braking transistor	Max. cycle time: 120 s; Max c.d.f.: 25 %			
Protective function braking resistor (Error GTR7 always on)	7)			
Max. motor cable length shielded	8) $l / m$		100	

Table 7: Overview of the HSD device data

- 1) Rated operation corresponds to  $U_N = 400V$ , rated switching frequency, output frequency = 50 Hz (4-pole standard asynchronous motor).
- 2) The output frequency is to be limited in such a way that it does not exceed 1/10 of the switching frequency. Notice! Devices with a maximum output frequency higher than 599Hz are subject to export restrictions.
- 3) The values refer in % to the rated output current  $I_N$ .
- 4) Observe limitations => „3.2.3.1 Overload characteristic (OL)“.
- 5) A detailed description of the Derating => „3.3.1 Switching frequency and temperature“.
- 6) The cyclic duration factor is additionally limited by the used braking resistor.
- 7) The feedback signal evaluation monitors the functionality of the braking transistor. The power is switched off via the internal mains input bridge of the AC supply.
- 8) The maximum cable length depends on various factors. Further information can be found in the corresponding filter instructions.

**3.2.2 Voltage and frequencies for 400V devices**

Input voltages and frequencies		
Rated input voltage	$U_N / V$	400
Rated mains voltage (USA)	$U_{N\_UL} / V$	480
Input voltage range	$U_{IN} / V$	280...550
Input phases		3
Mains frequency	$f_N / Hz$	50/60
Mains frequency tolerance	$f_N / Hz$	± 2

Table 8: Input voltages and frequencies of the 400V devices

DC link voltage		
DC link rated voltage @ $U_N = 400V$	$U_{N\_dc} / V$	565
DC link rated voltage @ $U_{N\_UL} = 480V$	$U_{N\_UL\_dc} / V$	680
DC link voltage working voltage range	$U_{IN\_dc} / V$	390...780

Table 9: DC link voltage for 400V devices



Output voltages and frequencies		
Output voltage at AC supply	<sup>1)</sup> $U_{out} / V$	0... $U_{N\_ac}$
Output frequency	<sup>2)</sup> $f_{out} / Hz$	0...599 (0...2000)
Output phase		3

Table 10: Output voltages and frequencies of the 400V devices

- <sup>1)</sup> The voltage to the motor is dependent on the actual input voltage and the control method („3.2.2.1 Example of the calculation of the possible motor voltage:“).
- <sup>2)</sup> The output frequency is to be limited in such a way that it does not exceed 1/10 of the switching frequency. Devices with a maximum output frequency higher than 599Hz are restricted for export.

3.2.2.1 Example of the calculation of the possible motor voltage:

The motor voltage for dimensioning of the drive is depending on the used components. The motor voltage reduces according to the following table:

Component	Reduction / %	Example
Mains choke $U_k$	4	Open-loop drive converter with mains- and motor choke at non-rigid supply system: 400 V mains voltage (100%) - 36 V reduced voltage (11%) = 356 V motor voltage
Drive converter open-loop	4	
Drive converter closed-loop	8	
Motor choke $U_k$	1	
Non-rigid supply system	2	

Table 11: Example of the calculation of the possible motor voltage:

3.2.3 Input and output currents / overload

Device size		30	31	32	33
Rated input current @ $U_N = 400V$	<sup>1)</sup> $I_{in} / A$	600	660	746	840
Rated input current @ $U_{N\_UL} = 480V$	<sup>1)</sup> $I_{in\_UL} / A$	513	575	646	726

Table 12: Input currents of the HSD devices

- <sup>1)</sup> The values resulting from rated operation with B6 rectifier circuit and mains choke 4%  $U_k$ .

Device size		30	31	32	33
Rated output current @ $U_N = 400V$	$I_N / A$	570	630	710	800
Rated output current @ $U_{N\_UL} = 480V$	$I_{N\_UL} / A$	495	545	615	692
Rated output overload (60 s)	<sup>1)</sup> $I_{60s} / \%$	125	125	125	125
Overload current	<sup>1)</sup> $I_{OL} / \%$	=> „3.2.3.1 Overload characteristic (OL)“			
Software current limit	<sup>1)2)</sup> $I_{lim} / \%$	125	125	125	125
Overcurrent	<sup>1)</sup> $I_{oc} / \%$	150	150	150	150

Table 13: Output currents and overload of the HSD devices

- <sup>1)</sup> The values refer in % to the rated output current  $I_N$ .
- <sup>2)</sup> Limitation of the current setpoint in closed-loop operation. This setpoint limit is not active in v/f operation.

### 3.2.3.1 Overload characteristic (OL)

All drive controllers can be operated at rated switching frequency with an utilisation of 125 % for 60 s.

The OL overload function is a root mean square (RMS) function.

The greater the difference between the overload and underload phases, the greater the deviation of the RMS from the arithmetic mean value.

For extreme overloads (=> „*Figure 3: Switch-off time  $t$  depending on the overload  $I/I_N$  (OL)*“) the load is weighted more heavily. This means the load is provided with a factor for the calculation of the RMS value, by way that the overload protection function triggers, even if the RMS value does not reach 100%.

#### **Restrictions:**

- The thermal design of the heat sink is based on the rated operation. The following values are taken into account: Rated output current, ambient temperature, rated switching frequency, rated voltage.
- At high ambient temperatures and/or high heat sink temperatures (for example, by preceding utilisation nearby 100%) the drive controller can change to overtemperature error before triggering the protective function OL.
- At low output frequencies or switching frequencies higher than the rated switching frequency, the frequency-dependent maximum current can be exceeded before triggering the overload error OL and error OL2 can be triggered => „*3.2.3.2 Frequency-dependent maximum current (OL2)*“.

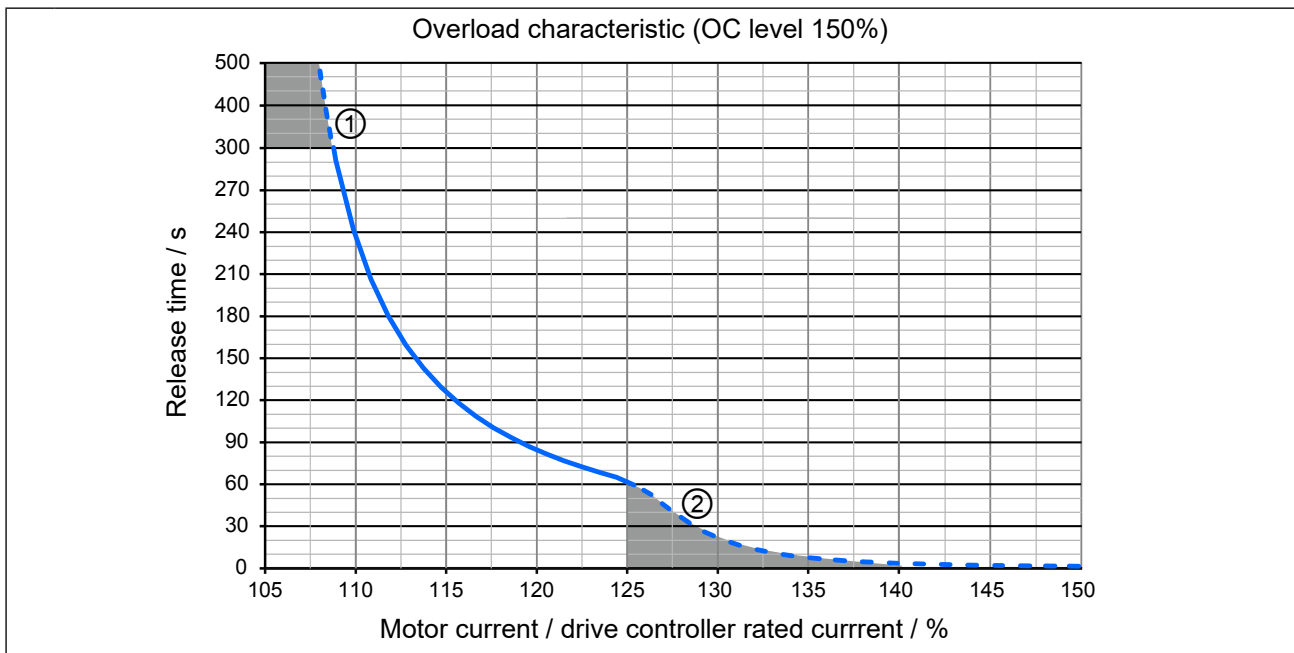

**Legend**

1	Thermal overload limit
2	Range for extreme overloads

Figure 3: Switch-off time  $t$  depending on the overload  $I/I_N$  (OL)

- On exceeding a load of 105 % the overload integrator starts.
- When falling below the integrator counts backwards.
- If the integrator reaches the overload characteristic "Error! Overload (OL)" is triggered.

After a cooling down period, the integrator can be reset now. The drive controller must remain switched on during the cooling down phase.

**Operation in the range of the thermal overload limit**

Due to the high steepness of the overload characteristic, the duration of a permissible overload in this range ① cannot be determined exactly. Therefore, the design of the drive controller should be assumed to have a maximum overload time of 300s.

3.2.3.2 Frequency-dependent maximum current (OL2)

The characteristics of the maximum currents for a switching frequency which are depending on the output frequency are different for each drive controller, but in general the following rule applies to housing 9:

- Lower maximum currents apply for switching frequencies > rated switching frequency.

If error (OL2) shall be triggered on exceeding the maximum currents or if the switching frequency is automatically reduced (derating) can be adjusted in the drive controller parameters.

The following characteristic curve indicates the permissible maximum current for the output frequency values 0 Hz, 6 Hz, 10 Hz, 25 Hz, 50 Hz and 100 Hz. Device size 30 HSD (fluid cooler) is represented exemplary.

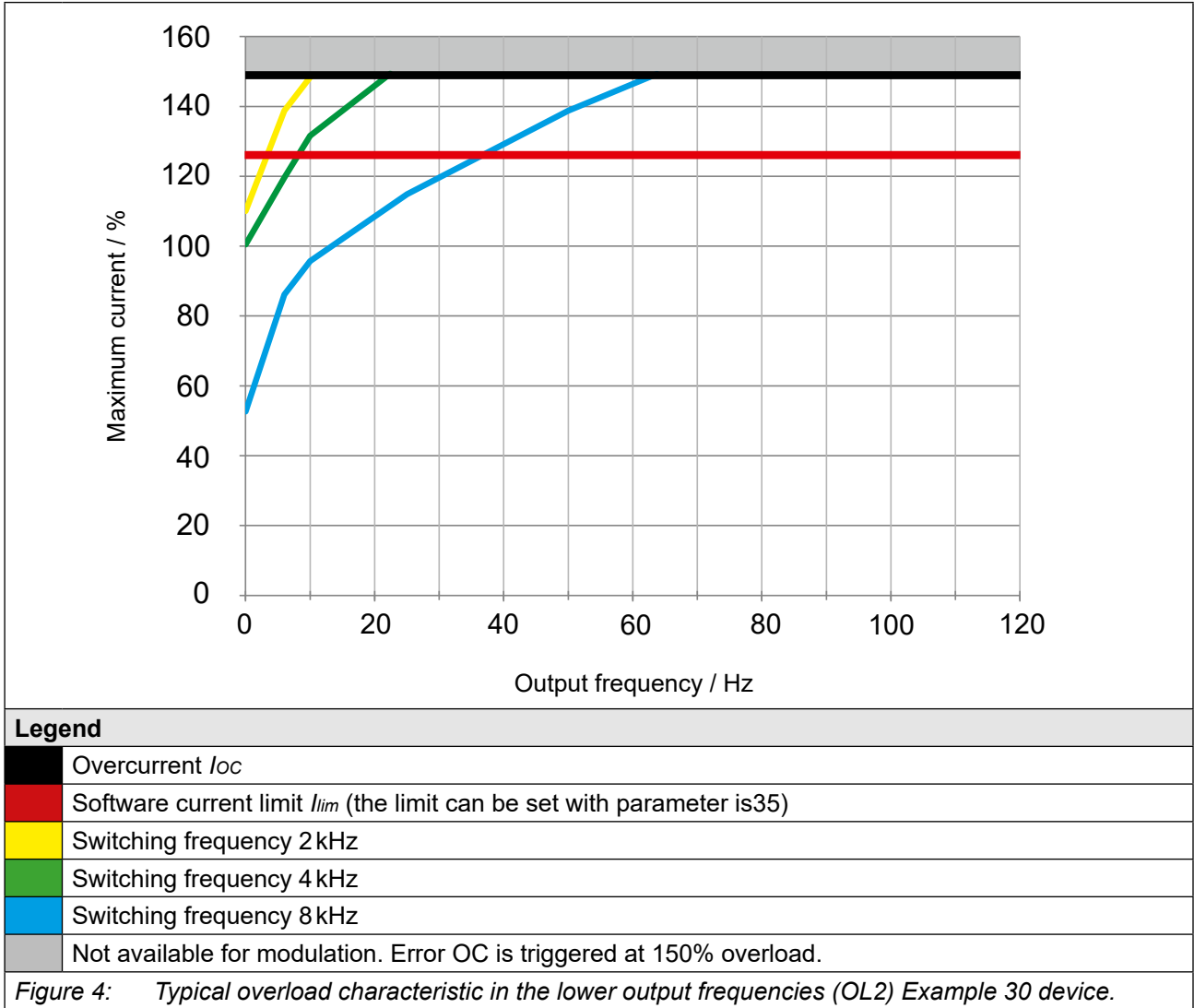

The frequency-dependent maximum current  $I_{out\_max}$  refers in % to the rated output current  $I_N$ .

The current remains constant from the last specified output frequency value.



The values for the respective device size are listed in the following tables.

**Frequency-dependent maximum current (fluid cooler water)**

Device size		30					
Rated switching frequency		8 kHz					
Output frequency	$f_{out}$ / Hz	0	6	10	25	50	100
Frequency-dependent maximum current @ $f_s$ Basic Time Period = 62.5 $\mu$ s (Parameter is22=0)	$i_{out\_max}$ %						
	2 kHz	110	139	148	150	150	150
	4 kHz	101	120	132	150	150	150
	8 kHz	53	86	96	115	139	150
Frequency-dependent maximum current @ $f_s$ Basic Time Period = 71.4 $\mu$ s (Parameter is22=1)	$i_{out\_max}$ %						
	1.75 kHz	110	139	148	150	150	150
	3.5 kHz	103	124	136	150	150	150
	7 kHz	65	95	105	124	150	150
Frequency-dependent maximum current @ $f_s$ Basic Time Period = 83.3 $\mu$ s (Parameter is22=2)	$i_{out\_max}$ %						
	1.5 kHz	110	139	148	150	150	150
	3 kHz	105	129	140	150	150	150
	6 kHz	77	103	114	134	150	150
Frequency-dependent maximum current @ $f_s$ Basic Time Period = 100 $\mu$ s (Parameter is22=3)	$i_{out\_max}$ %						
	1.25 kHz	110	139	148	150	150	150
	2.5 kHz	108	134	144	150	150	150
	5 kHz	89	111	123	144	150	150

Table 14: Frequency-dependent maximum current for device size 30 HSD (fluid cooler water)

Device size		31					
Rated switching frequency		8 kHz					
Output frequency	$f_{out}$ / Hz	0	6	10	25	50	100
Frequency-dependent maximum current @ $f_s$ Basic Time Period = 62.5 $\mu$ s (Parameter is22=0)	$i_{out\_max}$ %						
	2 kHz	110	130	139	150	150	150
	4 kHz	95	110	120	139	150	150
	8 kHz	48	78	87	104	126	150
Frequency-dependent maximum current @ $f_s$ Basic Time Period = 71.4 $\mu$ s (Parameter is22=1)	$i_{out\_max}$ %						
	1.75 kHz	110	130	139	150	150	150
	3.5 kHz	99	115	124	144	150	150
	7 kHz	60	86	95	113	135	150
Frequency-dependent maximum current @ $f_s$ Basic Time Period = 83.3 $\mu$ s (Parameter is22=2)	$i_{out\_max}$ %						
	1.5 kHz	110	130	139	150	150	150
	3 kHz	103	120	129	149	150	150
	6 kHz	71	94	103	121	145	150
Frequency-dependent maximum current @ $f_s$ Basic Time Period = 100 $\mu$ s (Parameter is22=3)	$i_{out\_max}$ %						
	1.25 kHz	110	130	139	150	150	150
	2.5 kHz	107	125	134	150	150	150
	5 kHz	83	102	111	130	150	150

Table 15: Frequency-dependent maximum current for device size 31 HSD (fluid cooler water)

Device size		32					
Rated switching frequency		8 kHz					
Output frequency	$f_{out}$ / Hz	0	6	10	25	50	100
<b>Frequency-dependent maximum current @ <math>f_s</math></b> <i>Basic Time Period = 62.5 <math>\mu</math>s (Parameter is22=0)</i>	$i_{out\_max}$ %						
	2 kHz	105	117	125	142	150	150
	4 kHz	85	98	106	123	146	150
<b>Frequency-dependent maximum current @ <math>f_s</math></b> <i>Basic Time Period = 71.4 <math>\mu</math>s (Parameter is22=1)</i>	$i_{out\_max}$ %						
	1.75 kHz	105	117	125	142	150	150
	3.5 kHz	90	103	110	128	148	150
<b>Frequency-dependent maximum current @ <math>f_s</math></b> <i>Basic Time Period = 83.3 <math>\mu</math>s (Parameter is22=2)</i>	$i_{out\_max}$ %						
	7 kHz	53	76	84	100	120	145
	1.5 kHz	105	117	125	142	150	150
<b>Frequency-dependent maximum current @ <math>f_s</math></b> <i>Basic Time Period = 100 <math>\mu</math>s (Parameter is22=3)</i>	$i_{out\_max}$ %						
	3 kHz	95	108	115	133	150	150
	6 kHz	63	84	91	108	129	148
<b>Frequency-dependent maximum current @ <math>f_s</math></b> <i>Basic Time Period = 100 <math>\mu</math>s (Parameter is22=3)</i>	$i_{out\_max}$ %						
	1.25 kHz	105	117	125	142	150	150
	2.5 kHz	100	112	120	137	150	150
	5 kHz	74	91	98	115	137	150

Table 16: Frequency-dependent maximum current for device size 32 HSD (fluid cooler water)

Device size		33					
Rated switching frequency		8 kHz					
Output frequency	$f_{out}$ / Hz	0	6	10	25	50	100
<b>Frequency-dependent maximum current @ <math>f_s</math></b> <i>Basic Time Period = 62.5 <math>\mu</math>s (Parameter is22=0)</i>	$i_{out\_max}$ %						
	2 kHz	100	109	114	130	147	150
	4 kHz	75	87	94	109	130	150
<b>Frequency-dependent maximum current @ <math>f_s</math></b> <i>Basic Time Period = 71.4 <math>\mu</math>s (Parameter is22=1)</i>	$i_{out\_max}$ %						
	8 kHz	34	61	68	82	99	126
	1.75 kHz	100	109	114	130	147	150
<b>Frequency-dependent maximum current @ <math>f_s</math></b> <i>Basic Time Period = 83.3 <math>\mu</math>s (Parameter is22=2)</i>	$i_{out\_max}$ %						
	3.5 kHz	81	93	99	114	134	150
	7 kHz	47	68	75	89	107	133
<b>Frequency-dependent maximum current @ <math>f_s</math></b> <i>Basic Time Period = 100 <math>\mu</math>s (Parameter is22=3)</i>	$i_{out\_max}$ %						
	1.5 kHz	100	109	114	130	147	150
	3 kHz	88	98	104	119	138	150
<b>Frequency-dependent maximum current @ <math>f_s</math></b> <i>Basic Time Period = 100 <math>\mu</math>s (Parameter is22=3)</i>	$i_{out\_max}$ %						
	6 kHz	56	74	81	96	114	140
	1.25 kHz	100	109	114	130	147	150
	2.5 kHz	94	104	109	124	142	150
	5 kHz	66	81	87	102	122	147

Table 17: Frequency-dependent maximum current for device size 33 HSD (fluid cooler water)

3.2.4 Power dissipation at rated operation

Device size		30	31	32	33
Rated switching frequency	$f_{SN}$ / kHz	8	8	8	8
Power dissipation at rated operation	<sup>1)</sup> $P_D$ / kW	8,05	9	10.5	12

Table 18: Power dissipation of the HSD devices

<sup>1)</sup> Rated operation corresponds to  $U_N = 400$  V;  $f_{SN}$ ;  $I_N$ ;  $f_N = 50$  Hz (typically value)

3.2.5 Fusing of the HSD devices

Device size	Max. size of the fuse / A				
	$U_N = 400$ V gG (IEC)	$U_N = 480$ V class "L"	$U_N = 480$ V class "L"	$U_N = 480$ V gR	
	SCCR 100 kA	SCCR 30 kA	SCCR 42 kA	SCCR 100 kA	Type <sup>1)</sup>
30	630	601	---	630	SIBA GMBH 206xy32.630
					COOPER BUSSMANN 170M5xy2
					LITTELFUSE PSR032xy0630
31	700 (2x350)	700	---	700	SIBA GMBH 206xy32.700
					COOPER BUSSMANN 170M5xy3
					LITTELFUSE PSR032xy0700
32	800 (2x400)	800	---	800	SIBA GMBH 206xy32.800
					COOPER BUSSMANN 170M5xy4
					LITTELFUSE PSR032xy0800
33	900 (2x450)	---	900	900	SIBA GMBH 206xy32.900
					COOPER BUSSMANN 170M5xy5
					LITTELFUSE PSR032xy0900

Table 19: Fusing of the HSD devices

<sup>1)</sup> "x" stands for various indicators. "y" stands for different connection variants.



**Short-circuit capacity**

After requests from [EN 60439-1](#) and [EN 61800-5-1](#) the following is valid for the connection to a network: The devices are suitable for use in a circuit capable of delivering not more than 100 kA eff. unaffected symmetrical short-circuit current.



### 3.3 General electrical data

#### 3.3.1 Switching frequency and temperature

The drive controller cooling is designed by way that the heat sink overtemperature threshold is not exceeded at rated conditions. A switching frequency higher than the rated switching frequency also produces higher losses and thus a higher heat sink heating. If the heat sink temperature reaches a critical threshold ( $T_{DR}$ ), the switching frequency can be reduced automatically step by step. This prevents that the drive controller switches off due to overheating of the heat sink. If the heat sink temperature falls below the threshold  $T_{UR}$ , the switching frequency is increased back to the setpoint. At temperature  $T_{EM}$  the switching frequency is immediately reduced to rated switching frequency. „Derating“ must be activated, for this function to work.

##### 3.3.1.1 Switching frequencies and temperatures for fluid coolers (water)

Device size		30	31	32	33
Rated switching frequency	<sup>1)</sup> $f_{SN}$ / kHz	8	8	8	8
Max. switching frequency	<sup>1)</sup> $f_{S\_max}$ / kHz	8	8	8	8
Min. switching frequency	<sup>1)</sup> $f_{S\_min}$ / kHz	2	2	2	2
Max. heat sink temperature 1	$T_{HS1}$ / °C	85	85	85	85
Max. heat sink temperature 2	$T_{HS2}$ / °C	65	65	65	65
Max. heat sink temperature 3	$T_{HS3}$ / °C	75	75	75	75
Max. interior temperature power unit 1	$T_{ID\_PU1}$ / °C	55	55	55	55
Max. interior temperature power unit 2	$T_{ID\_PU2}$ / °C	70	70	70	70
Max. interior temperature power unit 3	$T_{ID\_PU3}$ / °C	90	90	90	90
Temperature for derating the switching frequency	$T_{DR}$ / °C	75	75	75	75
Temperature for uprating the switching frequency	$T_{UR}$ / °C	70	70	70	70
Temperature for switching to rated switching frequency	$T_{EM}$ / °C	80	80	80	80

Table 20: Switching frequency and temperature for HSD devices

<sup>1)</sup> The output frequency is to be limited in such a way that it does not exceed 1/10 of the switching frequency.

3.3.2 DC link / braking transistor function



**Activation of the braking transistor function.**

In order to be able to use the braking transistor, the function must be activated with the parameter "is30 braking transistor function".

For more information => [Programming manual](#)

**NOTICE**

**Falling below the minimum braking resistance value!**

**Destruction of the drive controller**

- ▶ The minimum brake resistance value must not fall below!

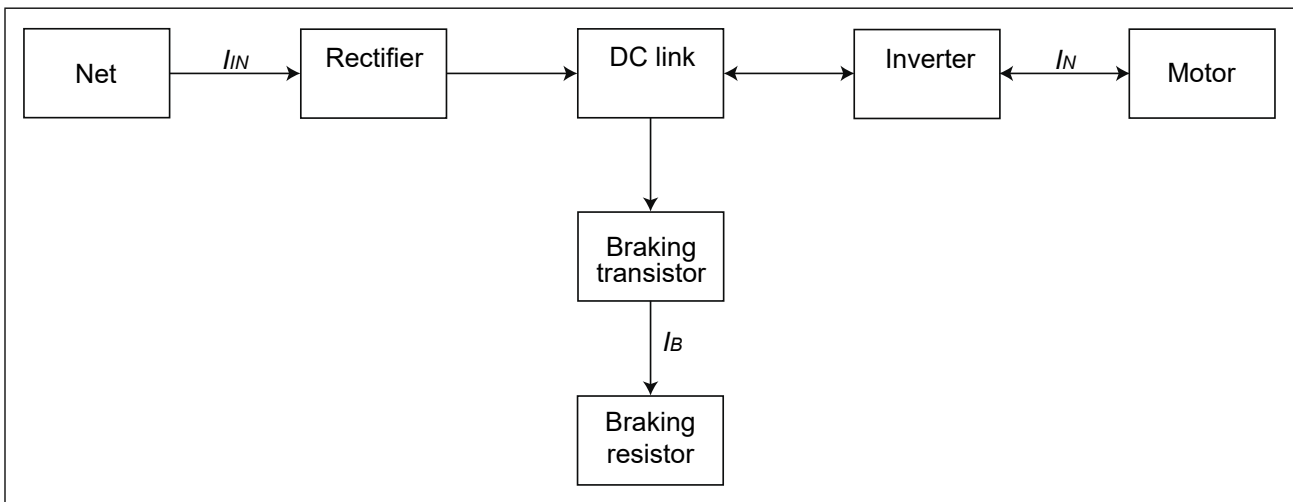

Figure 5: Block diagram of the energy flow

**NOTICE**

**Destruction of the drive controller!**

If the error "ERROR GTR7 always ON" occurs, the current consumption is switched off internally via the mains input bridge of the AC supply.

- ▶ The drive controller must be galvanically separated from the supply mains within 5 minutes!

## 3.3.2.1 DC link / braking transistor function

Device size		30	31	32	33
DC link rated voltage @ $U_N = 400V$	$U_{N\_dc} / V$	565			
DC link rated voltage @ $U_{N\_UL} = 480V$	$U_{N\_dc\_UL} / V$	680			
DC link voltage working voltage range	$U_{IN\_dc} / V$	390...780			
DC switch-off level "ERROR Underpotential" □	$U_{UP} / V$	240			
DC switch-off level "ERROR Overpotential" □	$U_{OP} / V$	840			
DC switch-off level braking resistor	<sup>1)</sup> $U_B / V$	780			
Max. braking current	$I_{B\_max} / A$	600			
Min. braking resistor value	$R_{B\_min} / \Omega$	1.3			
Braking transistor	<sup>2)</sup>	Max. cycle time: 120 s; Max c.d.f.: 25%			
Protective function for braking transistor		Short-circuit monitoring			
Protective function braking resistor (Error GTR7 always on)	<sup>3)</sup>	Feedback signal evaluation and current cut-off			
DC link capacity	$C / \mu F$	23400	23400	27900	27900

Table 21: DC link / braking transistor function of the HSD devices

- <sup>1)</sup> The DC switching level for the braking transistor is adjustable. The default value is the value specified in the table.
- <sup>2)</sup> The cyclic duration factor is additionally limited by the used braking resistor.
- <sup>3)</sup> The feedback signal evaluation monitors the functionality of the braking transistor. The power is switched off via the internal mains input bridge of the AC supply.

## 3.3.3 Sub-mounted braking resistors

Technical data of the sub-mounted braking resistors		
Braking resistor value	$R / \Omega$	1.5
Rated power	$P_D / W$	2200
Duty cycle referring to 120s @ $U_{N\_dc} = 780V$	duty cycle / s	0.6

Table 22: Sub-mounted braking resistors

**NOTICE****Observe the power dissipation of the sub-mounted braking resistors!**

In braking mode (with sub-mounted braking resistors), the power to be dissipated by the heat sink increases.

- Observe the power dissipation of the braking resistors when designing the cooling system.

## 3.3.4 Fan

Device size		30	31	32	33
Interior fan	Number	3	3	3	3
	Speed-variable	yes	yes	yes	yes

Table 23: Fan



The fans are speed-variable. They are automatically controlled to high or low speed depending on the setting of the temperature limits in the software.

**NOTICE****Destruction of the fan!**

- ▶ Take care that no foreign substances drop into the fan!

3.3.4.1 Switching behaviour of the fans

The temperature monitoring of the heat sinks controls the fans with different switch-on and switch-off points.

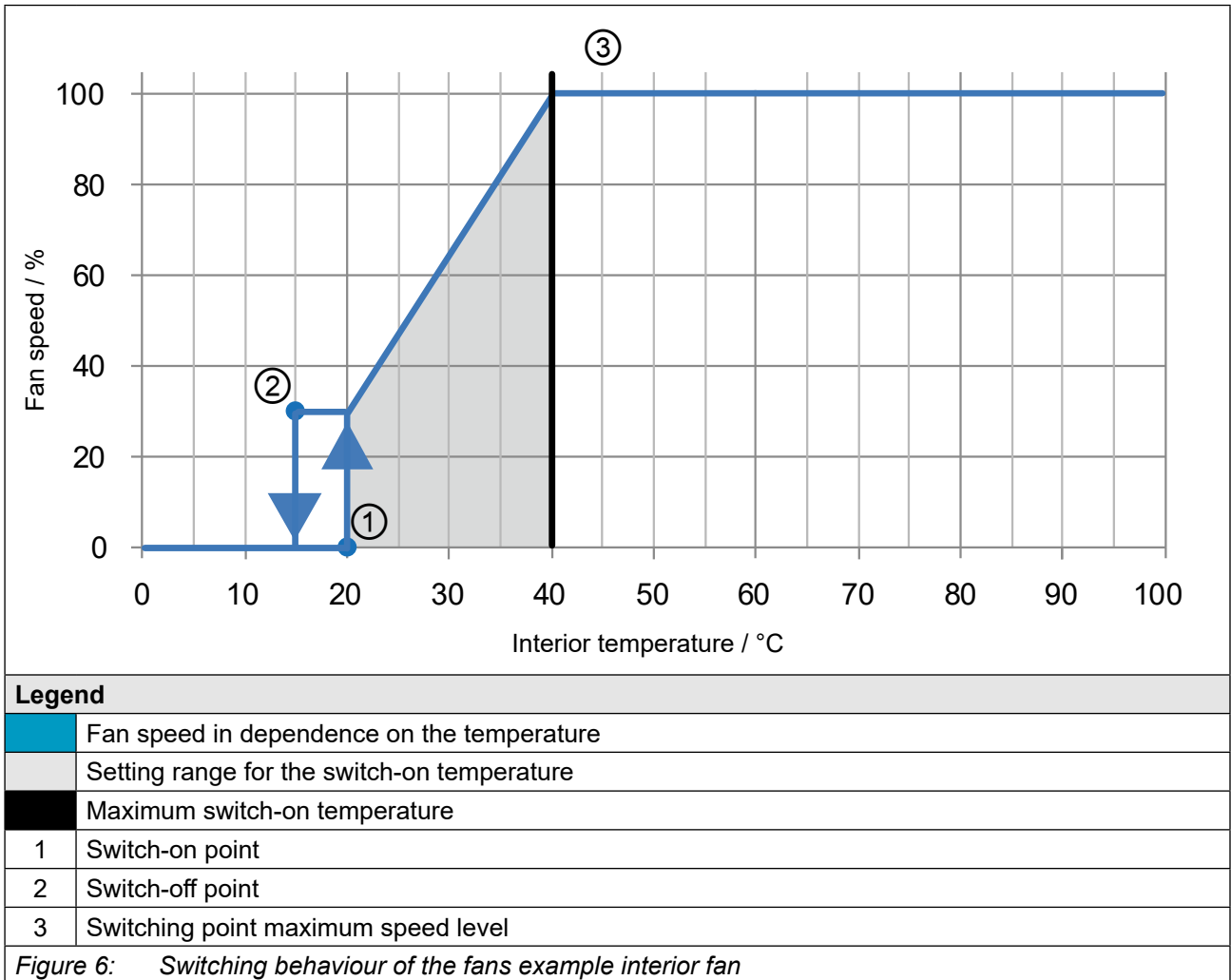

3.3.4.2 Switching points of the fans

The switching point for the switch-on temperature and the maximum speed level of the fans are adjustable. The following table shows the default values.

Fan		Interior
Switch-on temperature	$T / ^\circ\text{C}$	20
Maximum speed level	$T / ^\circ\text{C}$	40

Table 24: Switching points of the fans

## 4 Installation

### 4.1 Dimensions and weights

#### 4.1.1 Built-in version fluid cooler (water) High-Performance with aluminium heat sink

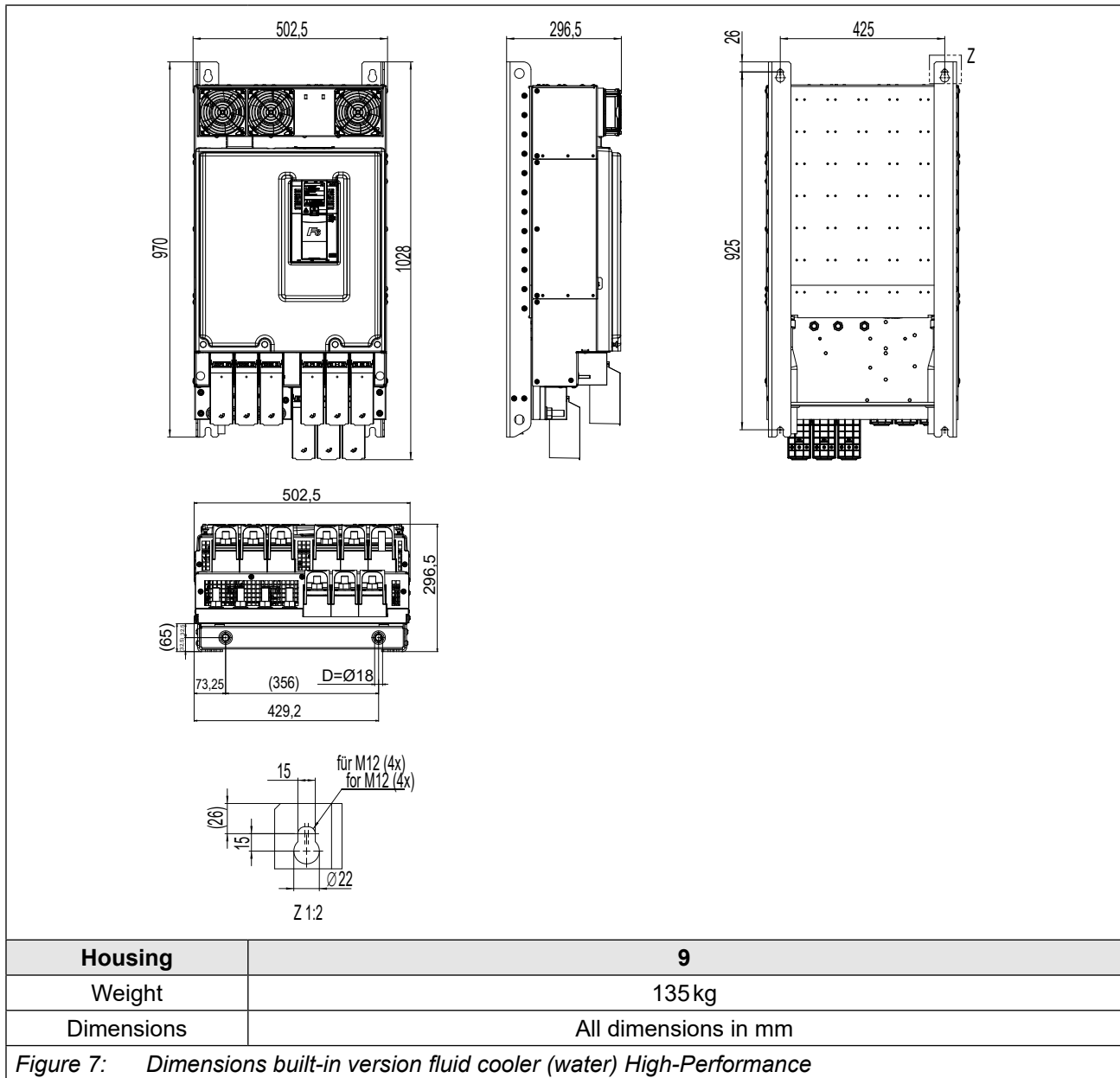

4.1.2 Push-through version fluid cooler (water) High-Performance with aluminium heat sink IP20, IP54-ready

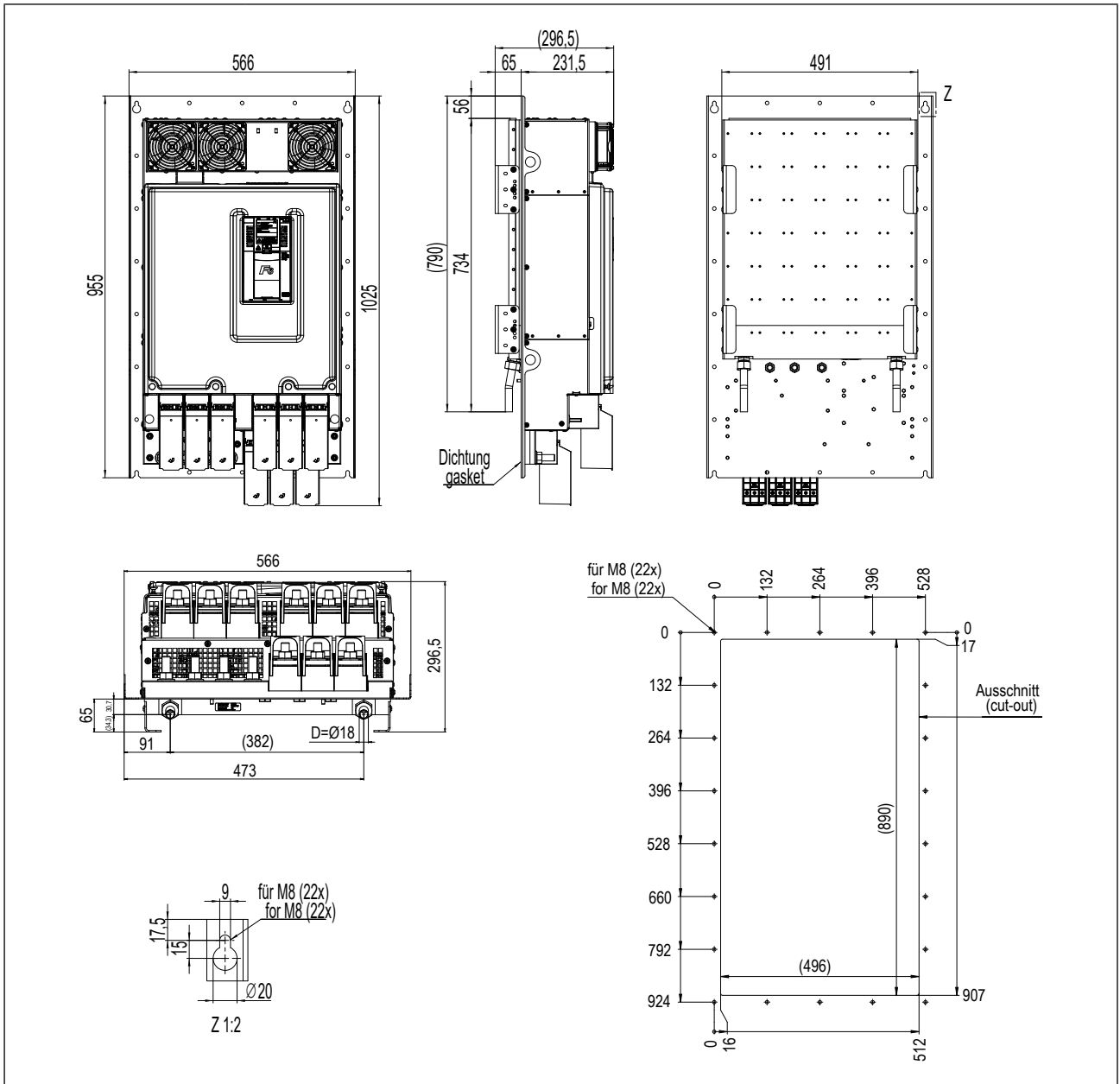

<b>Housing</b>	<b>9</b>
Weight	135 kg
Dimensions	All dimensions in mm

Figure 8: Dimensions push-through version fluid cooler (water) High-Performance IP20, IP54-ready

## 4.2 Control cabinet installation

### 4.2.1 Control cabinet installation

Drive controllers in housings 7, 8 and 9 have 2 threaded bushes for M10 ring bolts according to *DIN 580* on the top. These are used to accommodate appropriate lifting devices for transport.

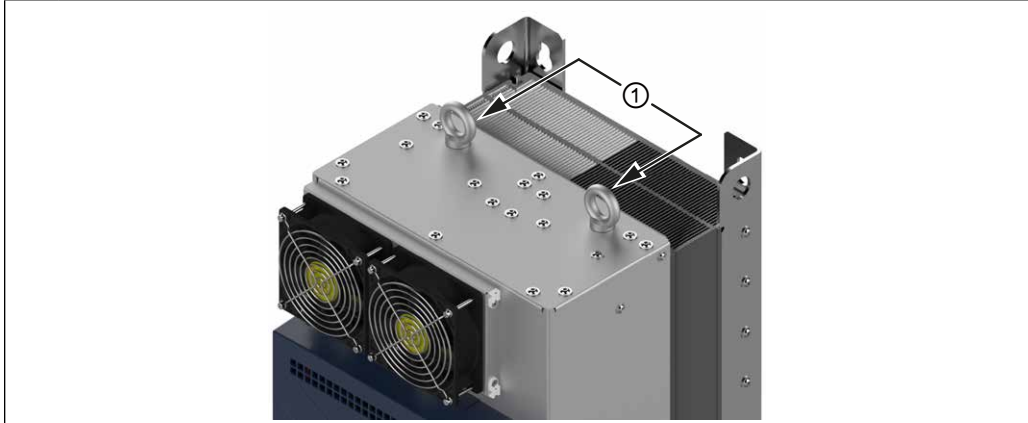

**Legend**

1 | M10 ring bolts

Figure 9: Example of an F6 in housing 8 with M10 ring bolts

#### 4.2.1.1 Devices with transport bracket

The transport bracket can be removed after mounting the drive converter. The transport brackets must be stored to make the drive converter transportable again in case of service.

**NOTICE**

**Damage caused by improper mounting**

► The transport brackets must not be used to fasten the drive converter!

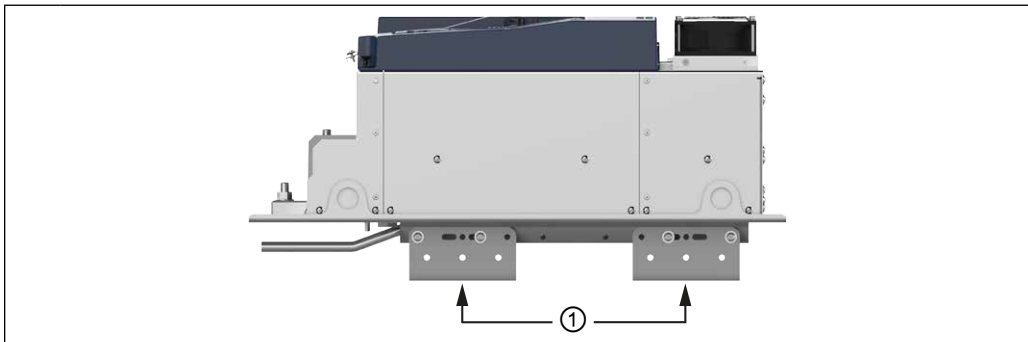

**Legend**

1 | Transport bracket

Figure 10: Example of an F6 housing 7 with transport brackets

**NOTICE**

**Damage to the water connections**

**Bending of the tubes!**

► Never set the device down or transport it without the transport brackets!



#### 4.2.2 Mounting instructions

For the mounting of the drive controllers the following mounting materials with the appropriate quality were tested by KEB.

Required material	Tightening torque
Hexagon-head screw ISO 4017 - M12 - 8.8	80 Nm 705 lb inch
Flat washer ISO 7090 - 12 - 200 HV	–
<i>Table 25: Mounting instructions for built-in version</i>	

Required material	Tightening torque
Hexagon-head screw ISO 4017 - M8 - 8.8	25 Nm 220 lb inch
Flat washer ISO 7090 - 8 - 200 HV	–
<i>Table 26: Mounting instructions for push-through version</i>	

### NOTICE

#### Use of other mounting material

- ▶ The alternatively selected fixing material must meet the above material characteristics (quality) and tightening torques!

The use of other fixing materials is beyond the control of KEB and is therefore the sole responsibility of the customer.

4.2.3 Mounting distances

Power dissipation for the control cabinet dimension => „3.2.4 Power dissipation at rated operation“. A lower value can be used here depending on the operating mode/load.



**Mounting of the drive controller**

For reliable operation, the drive controller must be mounted without any distance on a smooth, closed, metallicly bright mounting plate.

Mounting distances	Dimension	Distance in mm	Distance in inch
	A	150	6
	B	100	4
	C	30	1,2
	D	0	0
	E	0	0
	F <sup>1)</sup>	50	2
	<sup>1)</sup> Distance to preceding elements in the control cabinet door.		

Figure 11: Mounting distances

## 4.2.4 Installation of IP54-ready devices

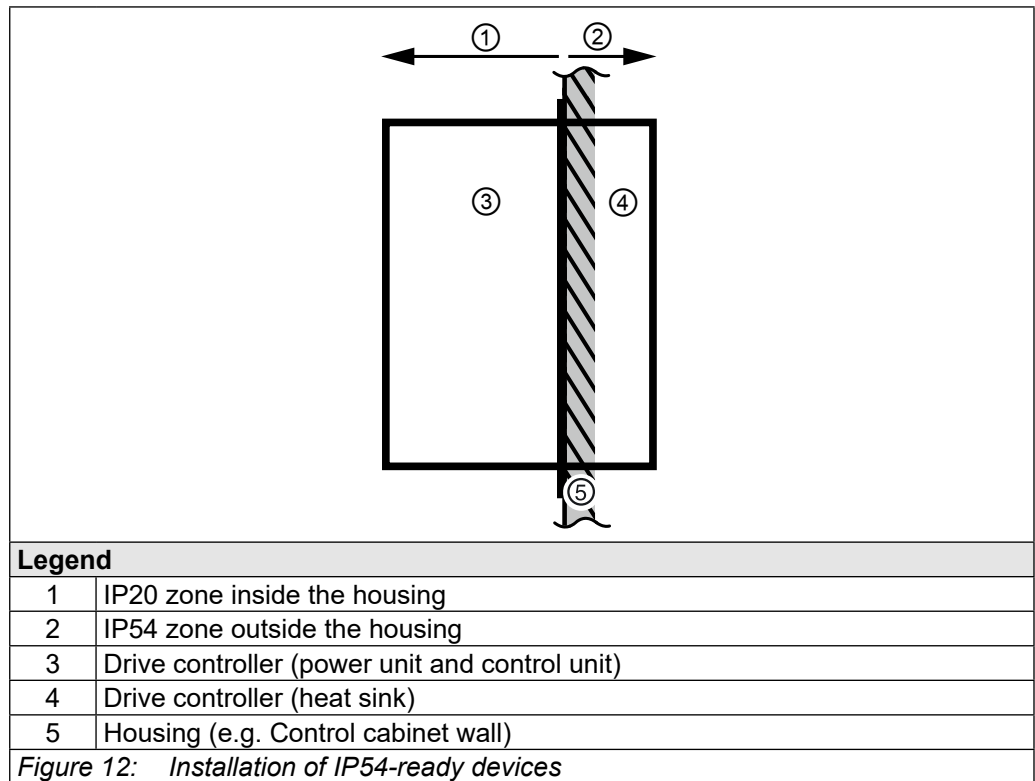
**IP54 zone: Heat sink outside the housing**

The protection class IP54 can only be achieved when the device is properly installed.

For proper installation, a suitable IP54 seal (=> „5.3.2 Seal for IP54-ready devices“) must be installed between heat sink and housing (e.g. control cabinet wall).

The tightness must be checked after the installation. If properly installed, the separation to the housing corresponds to degree of protection IP54.

In the case of fan-cooled units, the fans must be protected from negative environmental influences.

These include combustible, oily or dangerous fumes or gases, corrosive chemicals, coarse foreign bodies and excessive dust. This applies especially to the access of the heatsink from the top (air outlet). Icing is inadmissible.

UL: Device heat sink is classified as NEMA type 1

**IP20 zone: Device inside the housing**

This part is intended for the installation in a suitable housing for the required degree of protection (e.g. control cabinet).

The power connections are excluded => „3.1.1 Climatic environmental conditions“.

**NOTICE****Defect due to continuous splash water !**

- ▶ Never expose the device to continuous splashing water (e.g. direct exposure to rain)!

**4.2.5 Control cabinet ventilation**

If construction-conditioned the control cabinet cannot be without indoor ventilation, appropriate filters must avoid suction of foreign objects.

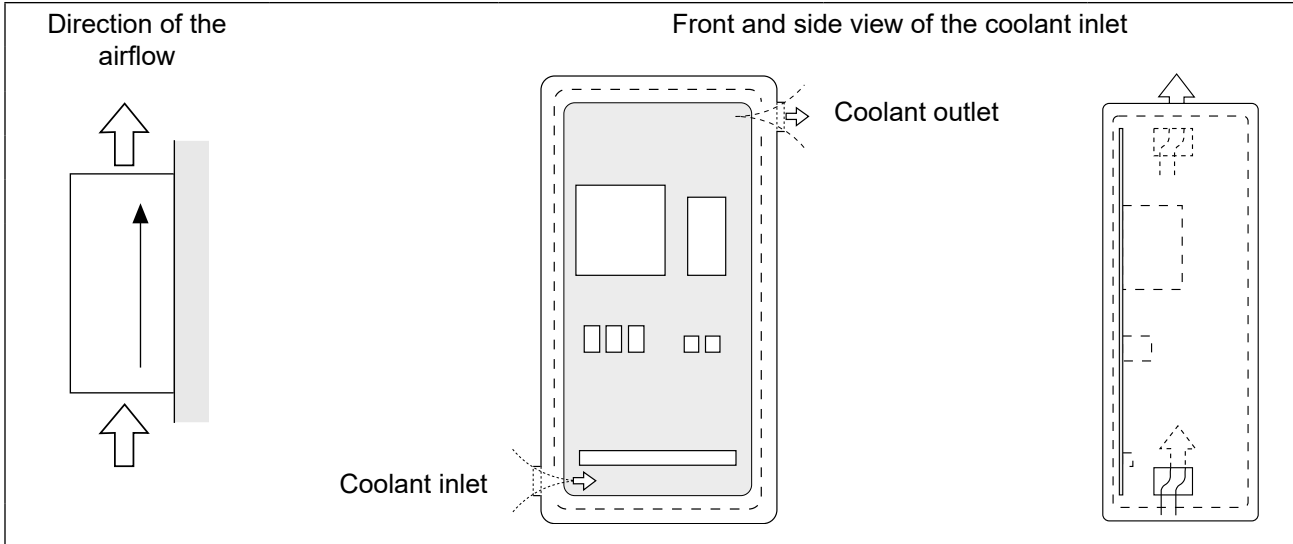
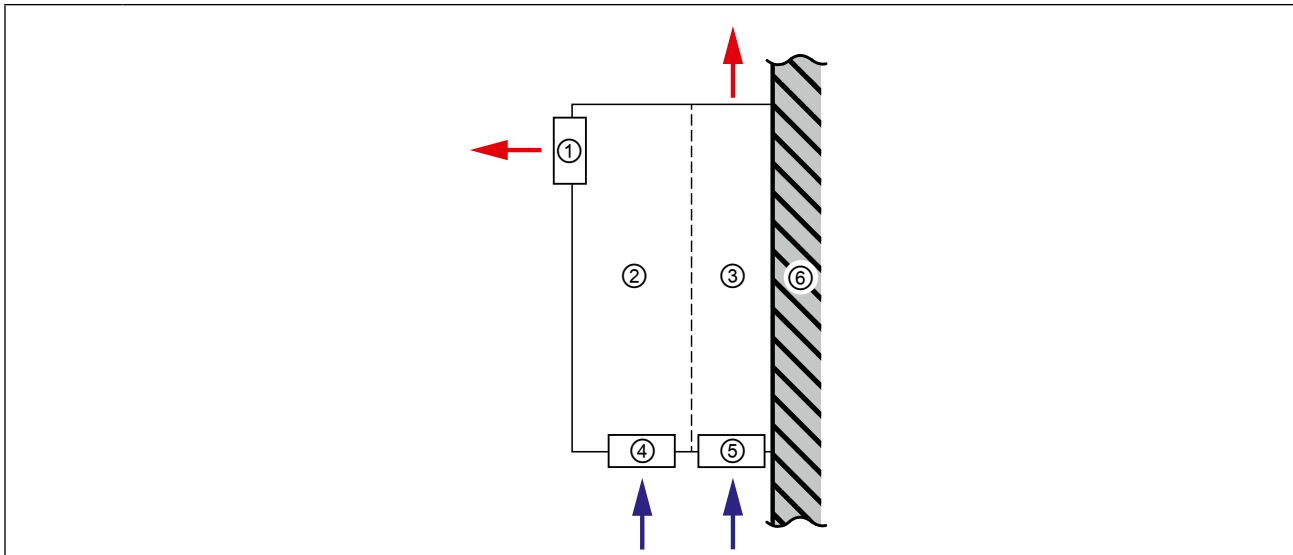

Figure 13: Control cabinet ventilation

**4.2.6 Airflow of the drive converter**



Legend	
	Airflow direction
1	Interior fan (from housing 4)
2	Drive converter (power unit and control)
3	Drive converter (heat sink)
4	Interior fan for (housing 2 and 3)
5	Heatsink fan
6	Housing (e.g. Control cabinet rear)

Figure 14: Airflow of the drive converter

## 5 Installation and connection

### 5.1 Overview of the COMBIVERT F6

Housing 9	No.	Name	Description
	1	---	Interior fan
	2 / 5	---	Shield clamps for shielded control cables
	3	---	Nameplate
	4	---	LEDs (see manual for control section chapter => "Overview") <ul style="list-style-type: none"> <li>• For control board COMPACT: FS without function.</li> <li>• For control card APPLICATION and PRO: Status indication of the safety module</li> </ul>
	6	X1A	Power circuit terminals for: <ul style="list-style-type: none"> <li>• Mains input</li> <li>• Braking resistor</li> <li>• DC voltage interface</li> <li>• Motor connection</li> </ul>
	7	PE	Protective earth; at connection to protective earth each terminal may be assigned only once

Figure 15: F6 housing 9 top view

Housing 9		No.	Name	Description
		1	---	Interior fan
		6	X1A	Power circuit terminals for: <ul style="list-style-type: none"> <li>• Mains input</li> <li>• Braking resistor</li> <li>• DC voltage interface</li> <li>• Motor connection</li> </ul>
		7	PE	Protective earth; at connection to protective earth each terminal may be assigned only once
		8	X1C	Terminal for: <ul style="list-style-type: none"> <li>• Motor temperature monitoring</li> <li>• Brake control</li> </ul>
		9	X3A	Encoder interface channel A
		10	X3B	Encoder interface channel B
<p>Figure 16: F6 housing 9 front view</p>				

Housing 9		No.	Name	Description
	1	---	Interior fan	
	2 / 5	---	Shield clamps for shielded control cables	
	11	S1	Rotary coding switch A	
	12	S2	Rotary coding switch B	
	13	X4C	Fieldbus interface (out)	
	14	X4B	Fieldbus interface (in)	
	15	X2B	Safety module	
	16	X2A	Control terminal block for <ul style="list-style-type: none"> <li>CAN bus</li> <li>Analog inputs and analog output</li> <li>Digital inputs and outputs</li> <li>24 V DC voltage supply</li> </ul>	
	17	---	Thread for screw eyes	

Figure 17: F6 housing 9 rear view with control board APPLICATION



Further information can be found in the respective control board manual.



Instructions for use COMBIVERT F6 control board APPLICATION  
[www.keb.de/fileadmin/media/Manuals/dr/ma\\_dr\\_f6-cu-a-inst-20118593\\_en.pdf](http://www.keb.de/fileadmin/media/Manuals/dr/ma_dr_f6-cu-a-inst-20118593_en.pdf)



Instructions for use COMBIVERT F6 control board COMPACT  
[www.keb.de/fileadmin/media/Manuals/dr/ma\\_dr\\_f6-cu-k-inst-20144795\\_en.pdf](http://www.keb.de/fileadmin/media/Manuals/dr/ma_dr_f6-cu-k-inst-20144795_en.pdf)



Instructions for use COMBIVERT F6 control board PRO  
[www.keb.de/fileadmin/media/Manuals/dr/ma\\_dr\\_f6-cu-p-inst-20182705\\_en.pdf](http://www.keb.de/fileadmin/media/Manuals/dr/ma_dr_f6-cu-p-inst-20182705_en.pdf)



## 5.2 Connection of the power unit

### NOTICE

#### Destruction of the drive controller!

- ▶ Never exchange mains input and motor output!

### 5.2.1 Connection of the voltage supply

The COMBIVERT F6 housing 9 can be supplied from the mains via the terminals L1, L2 and L3.

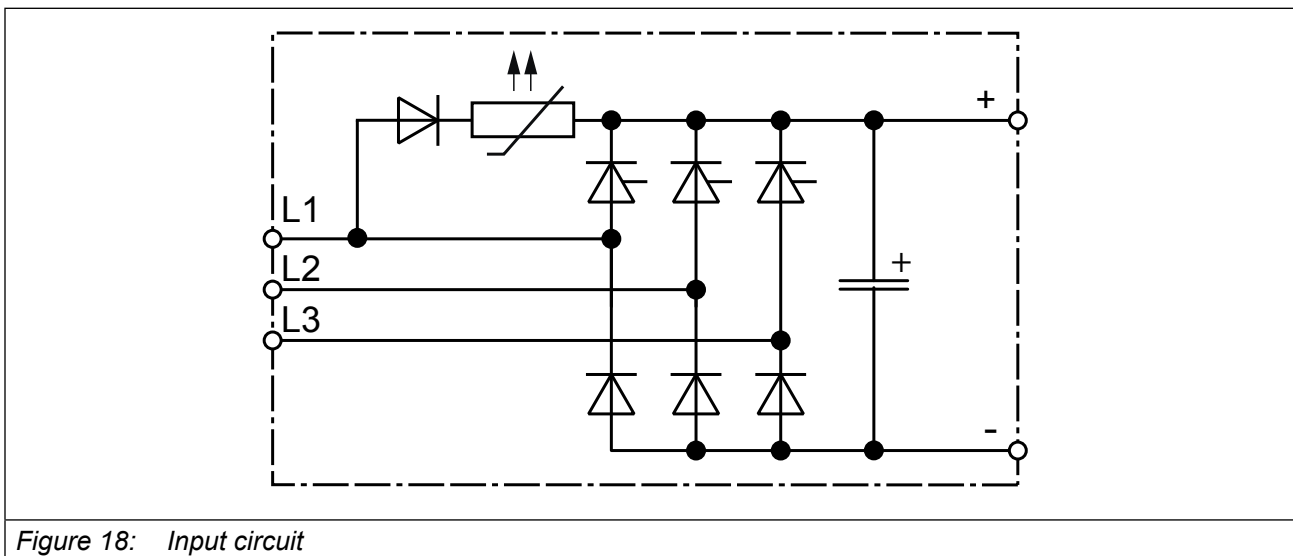

Figure 18: Input circuit



#### Minimum waiting period between two switch-on procedures 5 minutes!

Cyclic switching on and off of the device leads to temporary high resistance of the PTC resistor in the input. After the PTC has cooled down, recommissioning is possible without restriction.



5.2.1.1 Terminal block X1A for 400V devices



Name	Function	Terminal connection	Tightening torque	Max. number of conductors
L1	Mains connection 3-phase	16 mm stud for M16 crimp connector	35Nm 310lb inch	2
L2				
L3				
+	DC terminals			
-				
R	Connection for braking resistor (between + and R)			
U	Motor connection			
V				
W				

Figure 19: Terminal block X1A for 400V devices

5.2.2 Protective earth and functional earth



Protective and functional earth must not be connected to the same terminal.

5.2.2.1 Protective earth

The protective earth (PE) serves for electrical safety particularly personal protection in error case.



**Electric shock due to incorrect dimensioning!**

- ▶ Cross-section wire to ground should be selected according to *DIN IEC 60364-5-54!*

Name	Function	Terminal connection	Tightening torque	Max. number of conductors
PE,	Connection for protective earth	16 mm stud for M16 crimp connector	35 Nm 310 lb inch	1

Figure 20: Connection for protective earth



**Incorrect installation of the PE connection**

Only the M16 studs with nuts may be used to connect the protective earth!

5.2.2.2 Functional earthing

A functional earthing may also be necessary, if for EMC requirements additional potential equalization between devices or parts of the system must be available.



The use of the functional earth (FE) is not required if the frequency inverter is EMC-technically wired.

The functional earth may not be wired green/yellow!



Notes on EMC-compatible installation can be found here.  
[www.keb.de/fileadmin/media/Manuals/emv/0000neb0000.pdf](http://www.keb.de/fileadmin/media/Manuals/emv/0000neb0000.pdf)



5.2.3 AC mains connection

5.2.3.1 AC supply 3-phase

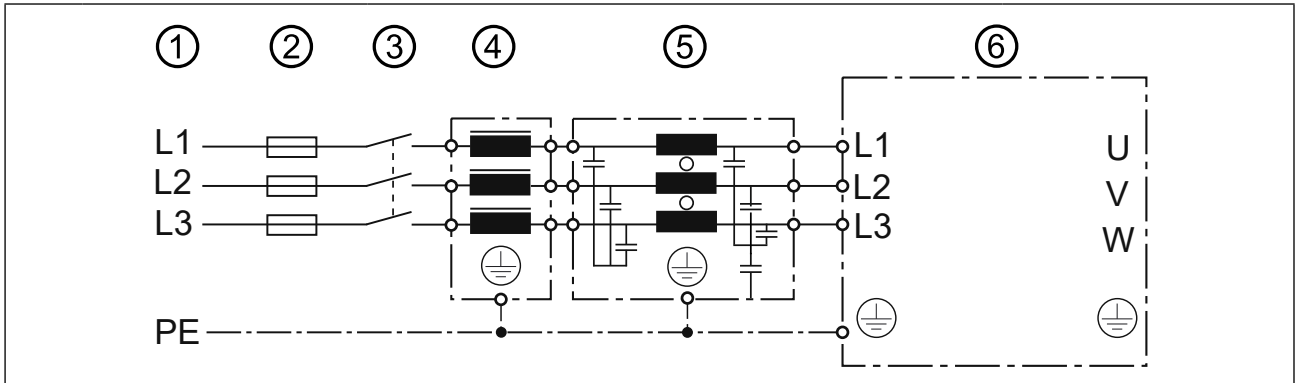

No.	Typ	Description	
1	Mains phase	3-phase	
	Mains form	TN, TT	IT
		The rated voltage between one phase conductor and earth potential (or the neutral point in the IT system) must not exceed 300V, USA UL: 480 / 277V. (For the IT system, a short-term disconnection must be ensured).	
Personal protection	RCMA with separator or RCD type B	Insulation monitors	
2	Mains fuses	see chapter "Protection of the drive controllers"	
3	Mains contactor	-	
4	Mains choke	see notes in chapter "Filters and chokes"	
5	HF filter for TN-, TT systems	Required for compliance with the limit values in accordance with <a href="#">EN 61800-3</a> .	
	HF filter for IT systems		
6	Drive controller	COMBIVERT F6	

Figure 21: Connection of the mains supply 3-phase

5.2.3.2 Supply cable

The conductor cross-section of the supply cable is determined by the following factors:

- Input current of the drive controller
- Used cable type
- Installation and ambient temperatures
- The locally valid electrical regulations



The application engineer is responsible for the design!

5.2.4 DC connection

**NOTICE**

**DC operation**

▶ DC operation is only permitted after consultation with KEB!

5.2.4.1 Terminal block X1A DC connection



Name	Function	Terminal connection	Tightening torque	Max. number of conductors
+	DC terminals	16 mm stud for M16 crimp connector	35Nm 310 lb inch	2
-				

Figure 22: Terminal block X1A DC connection

5.2.5 Connection of the motor

5.2.5.1 Wiring of the motor

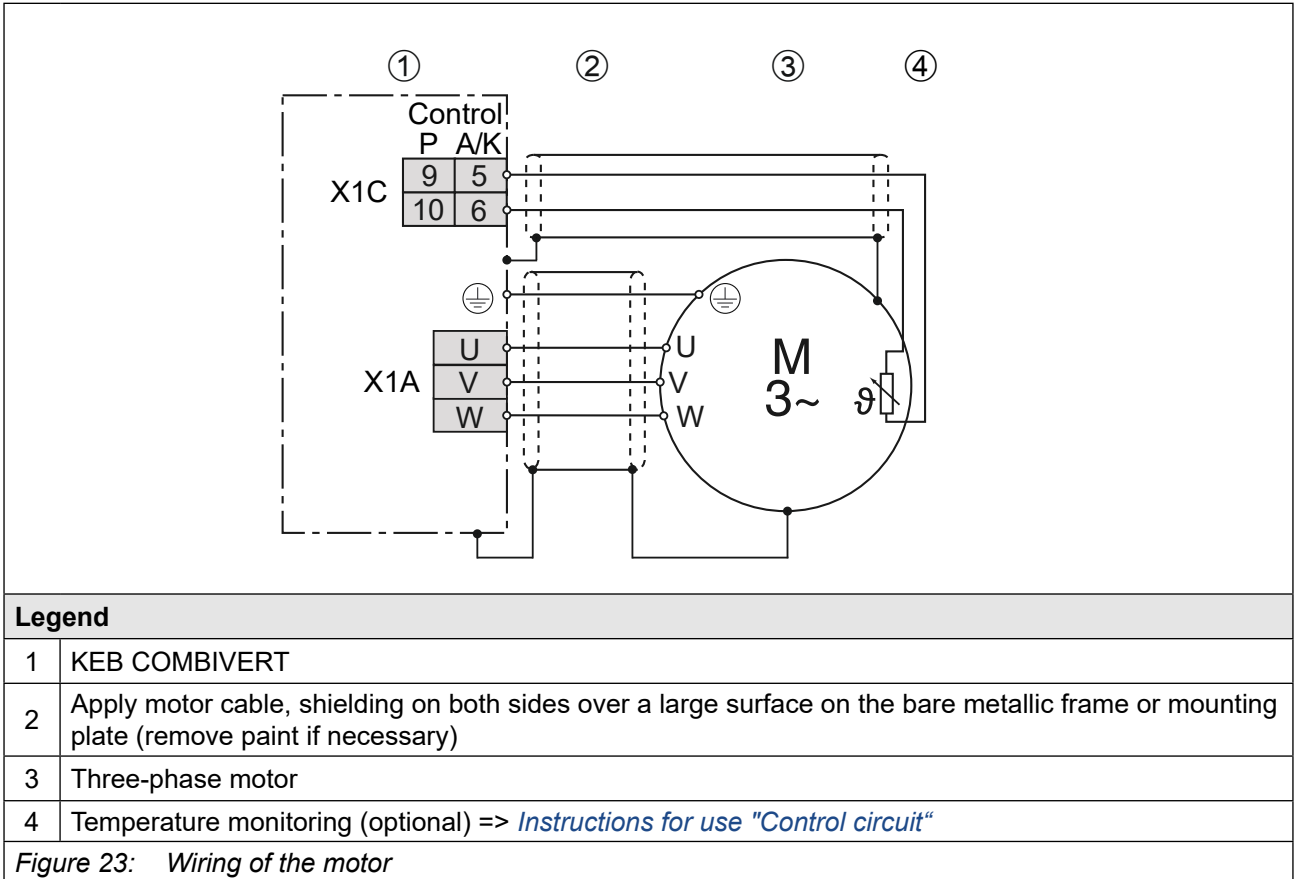

Figure 23: Wiring of the motor

## CONNECTION OF THE POWER UNIT

### 5.2.5.2 Terminal block X1A motor connection



Name	Function	Terminal connection	Tightening torque	Max. number of conductors
U	Motor connection	16 mm stud for M16 crimp connector	35 Nm 310lb inch	2
V				
W				

Figure 24: Terminal block X1A motor connection

5.2.5.3 Selection of the motor line

The correct cabling as well as the motor line itself play an important part in case of low power in connection with long motor line lengths. Low-capacitance line (phase/phase < 65 pF/m, phase/screen < 120 pF/m) at the inverter output have the following effects:

- allow major motor line lengths („5.2.5.4 Motor cable length and conducted interferences at AC supply“)
- better EMC properties (reduction of the common-mode output currents to earth)

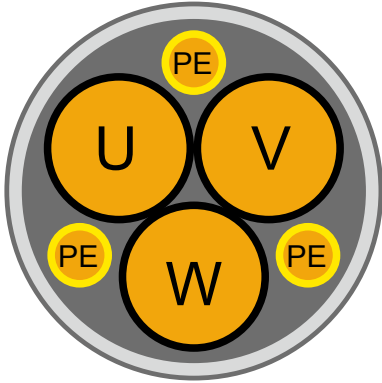
	<p>The use of shielded motor lines with symmetrical structure is required for higher motor power (from 30 kW). In these lines the protective earth conductor is tripartite and evenly arranged between the phase lines. A cable without protective earth conductor can be used if local regulations so permit. Then the protective earth conductor must be laid externally. Certain lines also permit the shield for the use as protective earth conductor. For this, observe the details of the line manufacturer!</p>
<p>Figure 25: Symmetrical motor line</p>	

5.2.5.4 Motor cable length and conducted interferences at AC supply

The maximum motor cable length is depending on the capacity of the motor cable as well as on the EMC emitted interference. External measures must be taken here (e.g. the use of a line filter).

- 

The cable length can be increased significantly by using motor chokes or motor filters. KEB recommends the use of motor chokes or filters for a cable length upto 25m.
- 

Further information on the motor cable length can be found in the corresponding filter instructions.

5.2.5.5 Motor cable length for parallel operation of motors

The resulting motor cable length for parallel operation of motors, or parallel installation with multiple cables arises from the following formula:

$$\text{resulting motor cable length} = \sum \text{single cable lengths} \times \sqrt{\text{Number of motor cables}}$$

5.2.5.6 Motor cable cross-section

The motor cable cross-section is dependent

- on the characteristic of the output current (e.g. harmonic content)
- on the real effective value of the motor current
- on the cable length
- on the type of the used cable
- on the ambient conditions such as bundling and temperature

5.2.5.7 Interconnection of the motor

**NOTICE**

**Incorrect behavior of the motor!**

- ▶ The connecting-up instructions of the motor manufacturer are always generally valid!

**NOTICE**

**Protect motor against voltage peaks!**

- ▶ Drive controllers switch at the output with high dv/dt. Voltage peaks that endanger the insulation system at the motor can occur especially in case of long motor cables (>15 m). A motor choke, a dv/dt-filter or sine-wave filter can be used to protect the motor with regard to the operating mode.



5.2.5.8 Connection of the temperature monitoring and brake control (X1C)

A switchable temperature evaluation is implemented in the COMBIVERT.

There are different types for the evaluation available. These are depending on the control board => *instruction manual „control board“*.

The desired operating mode can be adjusted via software (dr33). If the evaluation is not required, it must be deactivated via software (parameter pn12 = 7) => *Programming manual*

X1C	PIN	Name	Description
	1	BR+	Brake control / output +
	2	BR-	Brake control / output -
	3	reserved	–
	4	reserved	–
	5	TA1	Temperature detection / output +
	6	TA2	Temperature detection / output -

Figure 26: Terminal block X1C for control board APPLICATION and COMPACT

X1C	PIN	Name	Description
	1	BR+	Brake control / output +
	2	BR-	Brake control / output -
	3	0V	For supply of the checkback inputs
	4	24Vout	
	5	DIBR1	Checkback input 1 for brake and relay
	6	DIBR2	Checkback input 2 for brake and relay
	7	reserved	–
	8	reserved	–
	9	TA1	Temperature detection / output +
	10	TA2	Temperature detection / output -

Figure 27: Terminal block X1C for control board PRO

**NOTICE**

**Malfunctions due to incorrect line or laying!**

**Malfunctions of the control due to capacitive or inductive coupling.**

- ▶ Do not route cables from the motor temperature sensor (also shielded) together with control cables.
- ▶ Cables from the motor temperature sensor within the motor cables may only be used with double shielding!
- ▶ The input of the temperature detection has basic isolation.

## CONNECTION OF THE POWER UNIT

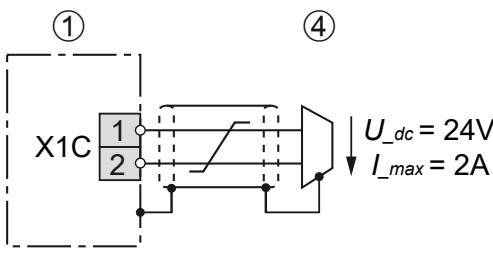
		<p>For control board APPLICATION and COMPACT. The voltage to the control of a brake is decoupled from the internal voltage supply. The brake works only with external voltage supply.</p> <p>For control board PRO The brake can be supplied with both, internal and external voltage. Voltage tolerances and output currents vary for internal and external voltage supply..</p>
1	COMBIVERT	<p>Respect the specifications =&gt; <a href="#">instruction manual „control board“</a></p>
4	Brake	
<p>Figure 28: Connection of the brake control</p>		

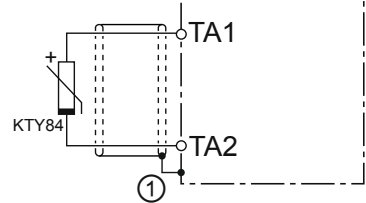
		<p>KTY sensors are polarized semiconductors and must be operated in forward direction! To this connect the anode to TA1 and the cathode to TA2! Non-observance leads to incorrect measurements in the upper temperature range. A protection of the motor winding is then no longer guaranteed.</p>
1	Connection via shield plate (if not available, place on the mounting plate).	
<p>Figure 29: Connection of a KTY sensor</p>		

### NOTICE

**No protection of the motor winding in case of wrong connection.**

- ▶ Operate KTY sensors in forward direction.
- ▶ KTY sensors may not be combined with other detections.



Further information about the wiring of the temperature monitoring and the brake control have to be observed in the respective control unit manual.

5.2.6 Connection and use of a braking resistor

**⚠ CAUTION**



**Fire risk by using brake resistors !**

- ▶ The risk of fire can be significantly reduced by using „intrinsically safe braking resistors“ or by using suitable monitoring functions / circuits.

**NOTICE**

**Destruction of the frequency inverter if the value has fallen below the minimum brake resistance value!**

- ▶ The minimum brake resistance value must not fall below!  
*„3.2 Device data of the 400 V devices“*

**⚠ CAUTION**



**Hot surfaces caused by load of the braking resistor!**

**Burning of the skin!**

- ▶ Cover hot surfaces safe-to-touch.
- ▶ Before touching, check the surface.
- ▶ If necessary, attach warning signs on the system.

5.2.6.1 Terminal block X1A connection braking resistor



Name	Function	Terminal connection	Tightening torque	Max. number of conductors
+	Connection for braking resistor (between + and R)	16 mm stud for M16 crimp connector	35 Nm 310lb inch	2
R				

Figure 30: Terminal block X1A connection braking resistor



At devices with sub-mounted braking resistors, there is no electrical connection to the braking transistor at terminal R!

## 5.2.6.2 Use of non-intrinsically safe braking resistors

**⚠ WARNING****Use of non-intrinsically safe braking resistors****Fire or smoke emission in case of overload or error!**

- ▶ Only use braking resistors with temperature sensor.
- ▶ Evaluate temperature sensor.
- ▶ Trigger an error at the drive controller (e.g. external input).
- ▶ Switch off input voltage (e.g. input contactor).
- ▶ Connection examples for non-intrinsically safe braking resistors  
=> *Instructions for use "Installation braking resistors"*.



Instructions for use "Installation braking resistors"  
[www.keb.de/fileadmin/media/Manuals/dr/ma\\_dr\\_braking-resistors-20116737\\_en.pdf](http://www.keb.de/fileadmin/media/Manuals/dr/ma_dr_braking-resistors-20116737_en.pdf)



## 5.3 Accessories

### 5.3.1 Filters and chokes

Voltage class	Drive controller size	HF filter	Mains choke 50 Hz / 4 % $U_k$
400V	30	• 33E6T60-3150	30Z1B04-1000
	31	• 33E6T60-3150	31Z1B04-1000
	32	• 33E6T60-3150	32Z1B04-1000
	33	• 33E6T60-3150	33Z1B04-1000

Table 27: Filters and chokes



The specified filters and chokes are designed for rated operation.

### 5.3.2 Seal for IP54-ready devices

Name	Material number
Flat seal IP54	00F6T45-0001

Table 28: Seal for IP54-ready devices

### 5.3.3 Side-mounted braking resistors



Technical data and design about non-intrinsically safe braking resistors

[www.keb.de/fileadmin/media/Manuals/dr/ma\\_dr\\_braking-resistors-20116737\\_en.pdf](http://www.keb.de/fileadmin/media/Manuals/dr/ma_dr_braking-resistors-20116737_en.pdf)



## 6 Operation of Liquid-Cooled Devices

### 6.1 Water-cooled devices

The use of water-cooled KEB COMBIVERT drive converters is offered, because there are process-caused coolants available with some applications. However, the following instructions must be observed.

#### 6.1.1 Heat sink and operating pressure

Design system	Material	max. operating pressure	Connection
Aluminium heat sink with stainless steel tubes	Stainless steel 1.4404	10 bar	=> „6.1.4 Connection of the cooling system“

#### NOTICE

#### Deformation of the heat sink!

- ▶ In order to avoid a deformation of the heat sink and the damages thereby, the indicated maximum operating pressure may not be exceeded briefly also by pressure peaks.
- ▶ Observe the Pressure Equipment Directive 2014/68/EU!

#### 6.1.2 Materials in the cooling circuit

For the screw connections and also for the metallic articles in the cooling circuit which are in contact with the coolant (electrolyte) a material is to be selected, which forms a small voltage difference to the heat sink in order to avoid contact corrosion and/or pitting corrosion (electro-chemical voltage series, see the following table). The specific case of application must be checked by the customer in tuning of the complete cooling circuit and must be classified according to the used materials. With hoses and seals take care that halogen-free materials are used.

A liability for occurring damages by wrongly used materials and from this resulting corrosion cannot be taken over!

Material	formed ion	Standard potential	Material	formed ion	Standard potential
Lithium	Li+	-3.04 V	Nickel	Ni <sup>2+</sup>	-0.25 V
Potassium	K+	-2.93 V	Tin	Sn <sup>2+</sup>	-0.14 V
Calcium	Ca <sup>2+</sup>	-2.87 V	Lead	Pb <sup>3+</sup>	-0.13 V
Sodium	Na+	-2.71 V	Iron	Fe <sup>3+</sup>	-0.037 V
Magnesium	Mg <sup>2+</sup>	-2.38 V	Hydrogen	2H+	0.00 V
Titan	Ti <sup>2+</sup>	-1.75 V	<b>Stainless steel (1.4404)</b>	<b>various</b>	<b>0.2...0.4 V</b>
Aluminium	Al <sup>3+</sup>	-1.67 V	Copper	Cu <sup>2+</sup>	0.34 V
Manganese	Mn <sup>2+</sup>	-1.05 V	Carbon	C <sup>2+</sup>	0.74 V
Zinc	Zn <sup>2+</sup>	-0.76 V	Silver	Ag+	0.80 V

*continued on the next page*

Material	formed ion	Standard potential	Material	formed ion	Standard potential
Chrome	Cr <sup>3+</sup>	-0.71 V	Platinum	Pt <sup>2+</sup>	1.20 V
Iron	Fe <sup>2+</sup>	-0.44 V	Gold	Au <sup>3+</sup>	1.42 V
Cadmium	Cd <sup>2+</sup>	-0.40 V	Gold	Au <sup>+</sup>	1.69 V
Cobald	Co <sup>2+</sup>	-0.28 V			

*Table 29: Electrochemical series / standard potentials against hydrogen*

**6.1.3 Requirements for the coolant**

The requirements for the coolant depend on the ambient conditions as well as the used cooling system.

General requirements for the coolant:

Requirement	Description
Standards	Corrosion protection according to <i>EN 12502-1...5</i> , water treatment and use of materials in cooling systems according to <i>VGB R 455 P</i> .
VGB Cooling water directive	The VGB cooling water directive ( <i>VGB R 455 P</i> ) contains instructions about common process technology of the cooling. Particularly the interactions between cooling water and components of the cooling system are described.
Abrasive substances	Abrasive substances as used in abrasive (quartz sand), clogging the cooling circuit.
Hard water	Cooling water may not cause scale deposits or loose excretions. The total hardness should be between 7...20 °dH, the carbon hardness at 3...10 °dH.
Soft water	Soft water (<7°dH) corrodes the material.
Frost protection	An appropriate antifreeze must be used for applications when the heat sink or the coolant is exposed temperatures below zero. Use only products of one manufacturer for a better compatibility with other additives. KEB recommends the antifreeze Antifrogen N from Clariant with a maximum volume content of 52 %.
Corrosion protection	Additives can be used as corrosion protection. In connection with frost protection the antifreeze must have a concentration of 20...25 Vol %, in order to avoid a change of the additives. Alternatively, an antifreeze / glycol with a concentration of 20% ... max. vol 52% can be used. If antifreeze is used, the water does not need to be provided with additional additives.

*Table 30: Requirements for the coolant*



Special requirements for open and half-open cooling systems:

Requirement	Description
Impurities	Mechanical impurities in half-open cooling systems can be counteracted when appropriate water filters are used.
Salt concentration	The salt content can increase through evaporation at half-open systems. Thus the water is more corrosive. Adding of fresh water and removing of process water works against.
Algae and myxobacteria	Algae and myxobacteria can arise caused by increased water temperature and contact with atmospheric oxygen. The algae and myxobacteria clog the filters and obstruct the water-flow. Biocide containing additives can avoid this. Especially at longer OFF periods of the cooling circuit preventive maintenance is necessary.
Organic materials	The contamination with organic materials must be kept as small as possible, because separate slime can be caused by this.

*Table 31: Special requirements for open and half-open cooling systems*



Damages at the device which are caused by clogged, corroded heat sinks or other obvious operating errors, leads to the loss of the warranty claims.

6.1.4 Connection of the cooling system

The connection to the cooling system can occur as closed or open cooling circuit. The connection to a closed cycle cooling circuit is recommended, because the danger of contamination of coolant is very small. Preferably also a monitoring of the pH value of the coolant should be installed.

Pay attention to a corresponding conductor cross-section at required equipotential bonding in order to avoid electro-chemical procedures.

Other elements in the cooling circuit such as pumps, shut-off valves, ventilation etc. must be attached according to the cooling system and the local conditions.

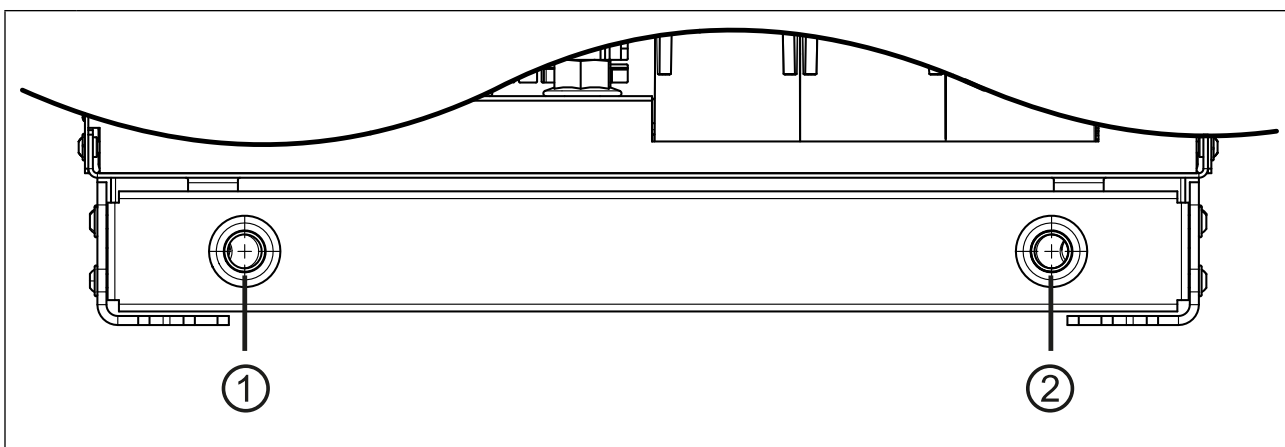

No.	Connection	Type
1	Flow	Open pipe ends for the connection of the cooling system Pipe diameter outside: 18 mm
2	Return flow	

Figure 31: Open pipe ends for the connection of the cooling system

**i** For the connection of the cooling system KEB recommends the use of functional nuts, e.g. from the manufacturer "Parker", type FMxxL71 (xx = pipe diameter).  
The recommended tightening torque is 80 Nm.

**i** To monitor the volume flow in the cooling system KEB recommends the use of a volume flow monitor.

### 6.1.5 Coolant temperature and moisture condensation

The flow temperature should be selected depending on the volume flow so that the heat sink temperature is always 10 K below the overtemperature level (OH) during rated operation. This avoids sporadic shutdown.

The maximum heat sink temperature can be found in chapter => „3.3.1 Switching frequency and temperature“.

#### 6.1.5.1 Condensation

A temperature difference between drive converter and ambient temperature can lead to condensation at high humidity.

Moisture condensation is dangerous for the drive converter. The drive converter can be destroyed through occurring short-circuits.

### NOTICE

#### Destruction of the drive converter due to short circuit!

- The user must guarantee that any moisture condensation is avoided!

#### 6.1.5.2 Supply of temper coolant

- The supply of optimally tempered coolant is possible by using heaters in the cooling circuit to control the coolant temperature.
- The following dew point table shows the coolant inlet temperature depending on the ambient temperature and air humidity.

Air humidity / %	10	20	30	40	50	60	70	80	90
Ambient temperature / °C									
-10	-34	-26	-22	-19	-17	-15	-13	-11	-11
-5	-29	-22	-18	-15	-13	-11	-8	-7	-6
0	-26	-19	-14	-11	-8	-6	-4	-3	-2
5	-23	-15	-11	-7	-5	-2	0	2	3
10	-19	-11	-7	-3	0	1	4	6	8
15	-18	-7	-3	1	4	7	9	11	13
20	-12	-4	1	5	9	12	14	16	18
25	-8	0	5	10	13	16	19	21	23
30	-6	3	10	14	18	21	24	26	28
35	-2	8	14	18	22	25	28	31	33
40	1	11	18	22	27	31	33	36	38
45	4	15	22	27	32	36	38	41	43
<b>Coolant inlet temperature / °C</b>									

Table 32: Dew point table



Information on coolant management is given in the following document

[www.keb.de/fileadmin/media/Techinfo/dr/an/ti\\_dr\\_an-liquid-cooling-00004\\_en.pdf](http://www.keb.de/fileadmin/media/Techinfo/dr/an/ti_dr_an-liquid-cooling-00004_en.pdf)



**NOTICE**

**Destruction of the heat sink at storage / transport of water-cooled devices!**

Observe the following points when storing water-cooled devices:

- ▶ Completely empty the cooling circuit
- ▶ Blow out the cooling circuit with compressed air

**NOTICE**

**Destruction of the drive converter due to condensation!**

- ▶ Use only NC valves!

**6.1.6 Permissible volume flow with water cooling**

The volume flow of the following table must be observed.

Device size		30	31	32	33
Min. volume flow	$Q_{min}$ / l/min	25	25	30	35
Max. volume flow	$Q_{max}$ / l/min	35	40	40	40

Table 33: Permissible volume flow with water cooling



The volume flow depends on the total power dissipation.

=> „6.1.7 Coolant heating“

**NOTICE**

**Destruction of the heat sink due to erosion!**

- ▶ The maximum permissible volume flow must not be exceeded.

### 6.1.7 Coolant heating

The following curve characteristics apply to a flow temperature of 55 °C and a glycol content of 52 %.

#### 6.1.7.1 Coolant heating

Volume flow depending on the total power dissipation and temperature difference between flow and return flow.

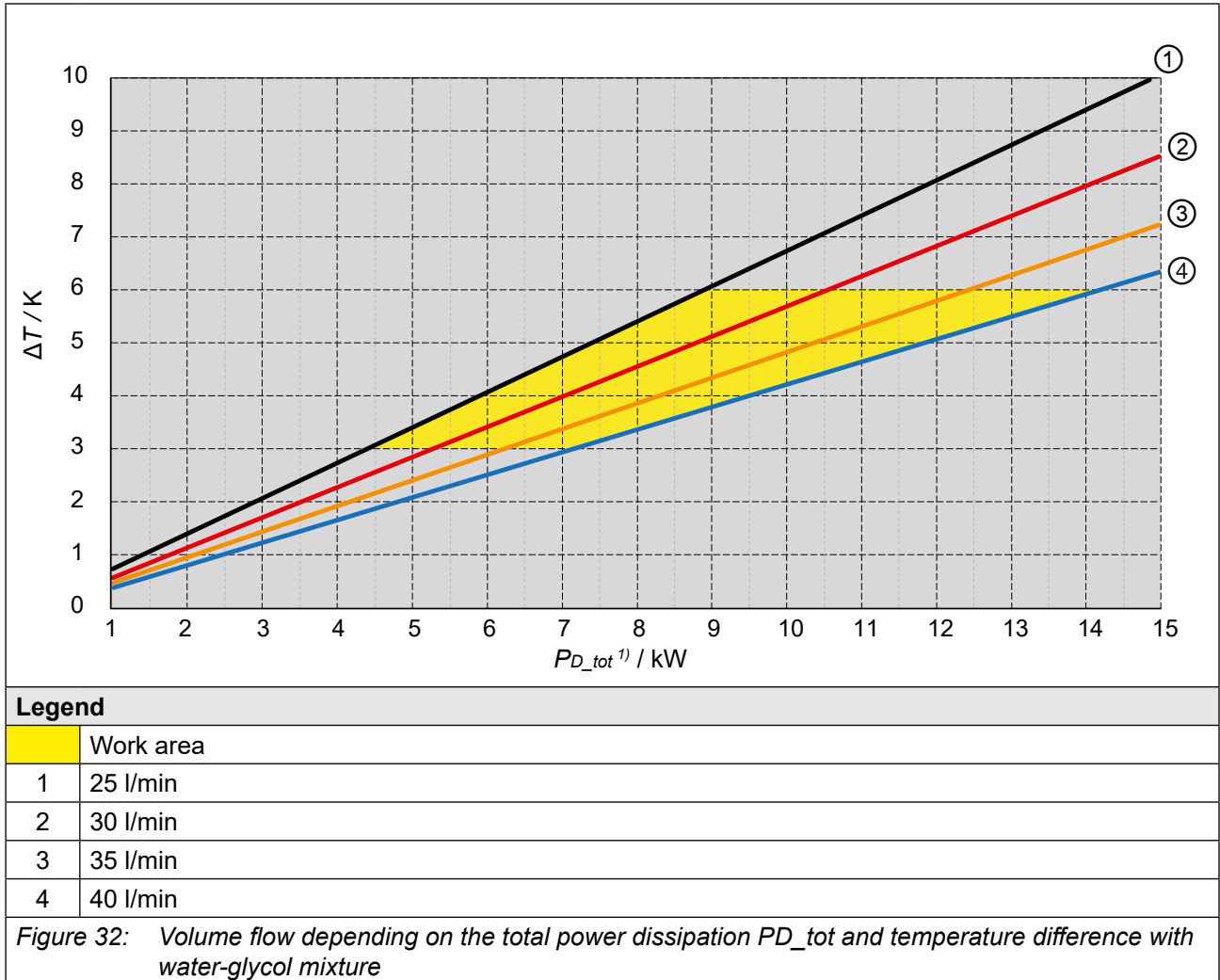

<sup>1)</sup>  $P_{D\_tot}$  can be higher than the power dissipation  $P_D$  during rated operation due to overload, higher switching frequency or sub-mounted braking resistors.

6.1.8 Typical pressure drop of the heat sink

- The curve characteristic shown below is valid for 25 °C flow temperature and a glycol content of 52 %.
- If higher flow temperatures are used, the pressure drop in the system decreases.
- This also applies to cooling media such as water or another glycol mixture.
- A glycol mixture from Clariant in a ratio of 52 % or 33 % is recommended.

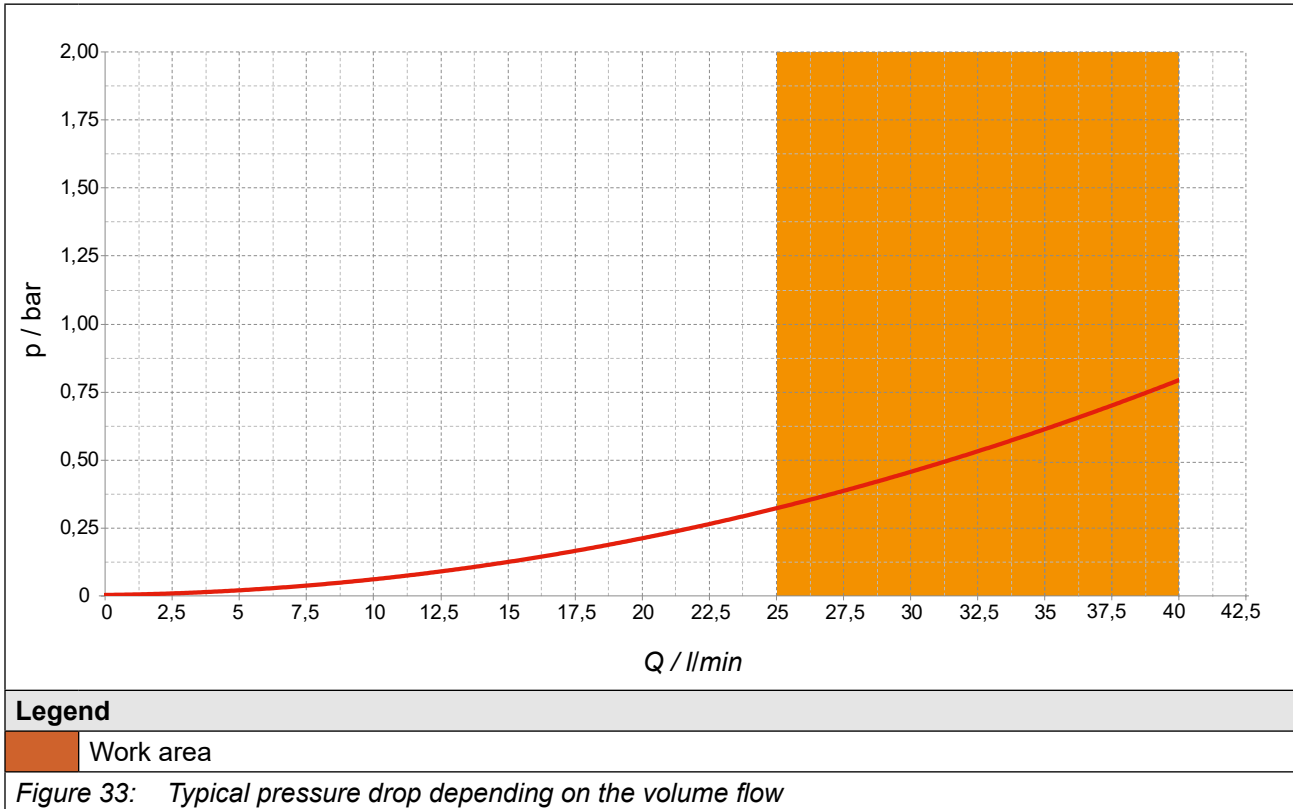

## 7 Certification

### 7.1 CE marking

The drive controllers labelled with a CE logo comply with the requirements of the Machinery Directive as well as the EMC and Rohs Directives and energy efficiency regulations.



---

For further information regarding the CE declarations of conformity  
=> „7.3 Further informations and documentation“

---

## 7.2 UL certification

	<p>Acceptance according to UL is marked at KEB drive controllers with the adjacent logo on the nameplate.</p>
---	---

To be conform according to UL for use on the North American and Canadian Market the following additionally instructions must be observed (original text of the UL-File):

- All models:  
Maximum Surrounding Air Temperature: 45°C
- Use 75°C Copper Conductors Only
- Control Circuit Overcurrent Protection Required
- Integral solid state short circuit protection does not provide branch circuit protection. Branch circuit protection must be provided in accordance with the Manufacturer Instructions, National Electrical Code and any additional local codes.

CSA: For Canada: Integral solid state short circuit protection does not provide branch circuit protection. Branch circuit protection must be provided in accordance with the Canadian Electrical Code, Part I.

LA PROTECTION INTÉGRÉE CONTRE LES COURTSCIRCUITS N'ASSURE PAS LA PROTECTION DE LA DÉRIVATION. LA PROTECTION DE LA DÉRIVATION DOIT ÊTRE EXÉCUTÉE CONFORMÉMENT AU CODE CANADIEN DE L'ÉLECTRICITÉ, PREMIÈRE PARTIE.

- Only for use in non-corner grounded type WYE source not exceeding 277V phase to ground.
- For installations according to Canadian National Standard C22.2 No. 274-13:  
For use in Pollution Degree 2 and Overvoltage Category III environments only.
- Models 30F6, 31F6, 32F6: Suitable For Use On A Circuit Capable Of Delivering Not More Than 30000 rms Symmetrical Amperes, 480 Volts Maximum when protected by Class L Fuses, see instruction manual for Branch Circuit Protection details.

Models 33F6: Suitable For Use On A Circuit Capable Of Delivering Not More Than 42000 rms Symmetrical Amperes, 480 Volts Maximum when protected by Class L Fuses, see instruction manual for Branch Circuit Protection details.

All Models: Suitable For Use On A Circuit Capable Of Delivering Not More Than 100,000 rms Symmetrical Amperes, 480 Volts Maximum when protected by Semiconductor Fuses by SIBA, Type 206xy32.630, or by Bussmann, Type 170M5xxx or by Littelfuse, Type PSR032xyxxxx, see instruction manual for Branch Circuit Protection details.



- **WARNING** – The opening of the branch circuit protective device may be an indication that a fault current has been interrupted. To reduce the risk of fire or electrical shock, current-carrying parts and other components of the controller should be examined and replaced if damaged. If burnout of the current element of an overload relay occurs, the complete overload relay must be replaced.

CSA: For Canada:

“ATTENTION - LE DÉCLENCHEMENT DU DISPOSITIF DE PROTECTION DU CIRCUIT DE DÉRIVATION PEUT ÊTRE DÛ À UNE COUPURE QUI RÉSULTE D'UN COURANT DE DÉFAUT. POUR LIMITER LE RISQUE D'INCENDIE OU DE CHOC ÉLECTRIQUE, EXAMINER LES PIÈCES PORTEUSES DE COURANT ET LES AUTRES ÉLÉMENTS DU CONTRÔLEUR ET LES REMPLACER S'ILS SONT ENDOMMAGÉS. EN CAS DE GRILLAGE DE L'ÉLÉMENT TRAVERSÉ PAR LE COURANT DANS UN RELAIS DE SURCHARGE, LE RELAIS TOUT ENTIER DOIT ÊTRE REMPLACÉ.”

- Brake resistor ratings and duty cycle:
  - Duty cycle 25%
  - Max. 30 sec on-time / 90 sec off-time
- For liquid cooled devices:
  - Maximum working pressure: 10 bar (145 psi)
  - Liquid inlet temperature range: +5...+40°C (standard) and +5...+55°C (high performance)
  - Min water flow rate: 10 l/min

### 7.3 Further informations and documentation

You find supplementary manuals and instructions for the download under [www.keb.de/de/service/downloads](http://www.keb.de/de/service/downloads)

#### General instructions

- EMC and safety instructions
- Manuals for additional control boards, safety modules, fieldbus modules, etc.

#### Instruction and information for construction and development

- Input fuses in accordance with UL
- Programming manual for control and power unit
- Motor configurator to select the appropriate drive converter and to create downloads for parameterizing the drive converter

#### Approvals and approbations

- Declaration of conformity CE
- TÜV certificate
- FS certification

#### Others

- COMBIVIS, the software for comfortable parameterization of drive converters via PC (available per download)
- EPLAN drawings

## 8 Revision history

Version	Date	Description
00	2022-12	Completion pre-series version
01	2023-06	Product description, technical data, coolant heating adapted.
02	2023-08	Device size 30 and UL certification included.
03	2023-11	Corrections of the currents
04	2024-01	Series version of the manual created, OL2 currents adapted.



**Austria** | KEB Automation GmbH  
Ritzstraße 8 4614 Marchtrenk Austria  
Tel: +43 7243 53586-0 Fax: +43 7243 53586-21  
E-Mail: info@keb.at Internet: www.keb.at

**Benelux** | KEB Automation KG  
Bd Paapsemiaan 20 1070 Anderlecht Belgium  
Tel: +32 2 447 8580  
E-Mail: info.benelux@keb.de Internet: www.keb.de

**Brazil** | KEB South America - Regional Manager  
Rua Dr. Omar Pacheco Souza Riberio, 70  
CEP 13569-430 Portal do Sol, São Carlos Brazil  
Tel: +55 16 31161294 E-Mail: roberto.arias@keb.de

**Czech Republic** | KEB Automation GmbH  
Videnska 188/119d 61900 Brno Czech Republic  
Tel: +420 544 212 008  
E-Mail: info@keb.cz Internet: www.keb.cz

**France** | Société Française KEB SASU  
Z.I. de la Croix St. Nicolas 14, rue Gustave Eiffel  
94510 La Queue en Brie France  
Tel: +33 149620101 Fax: +33 145767495  
E-Mail: info@keb.fr Internet: www.keb.fr

**Germany | Geared Motors**  
KEB Antriebstechnik GmbH  
Wildbacher Straße 5 08289 Schneeberg Germany  
Telefon +49 3772 67-0 Telefax +49 3772 67-281  
Internet: www.keb-drive.de E-Mail: info@keb-drive.de

**Italy** | KEB Italia S.r.l. Unipersonale  
Via Newton, 2 20019 Settimo Milanese (Milano) Italia  
Tel: +39 02 3353531 Fax: +39 02 33500790  
E-Mail: info@keb.it Internet: www.keb.it

**Japan** | KEB Japan Ltd.  
41-1-601 Kanda, Higashimatsushitacho, Chiyoda Ward  
Tokyo 101 - 0042 Japan  
Tel: +81 3 3525-7351 Fax: +81 3 3525-7352  
E-Mail: info@keb.jp Internet: www.keb.jp

**P. R. China** | KEB Power Transmission Technology (Shanghai) Co. Ltd.  
No. 435 QianPu Road Chedun Town Songjiang District  
201611 Shanghai P.R. China  
Tel: +86 21 37746688 Fax: +86 21 37746600  
E-Mail: info@keb.cn Internet: www.keb.cn

**Poland** | KEB Automation KG  
Tel: +48 60407727  
E-Mail: roman.trinczek@keb.de Internet: www.keb.de

**Republic of Korea** | KEB Automation KG  
Deoksan-Besttel 1132 ho Sangnam-ro 37  
Seongsan-gu Changwon-si Gyeongsangnam-do Republic of Korea  
Tel: +82 55 601 5505 Fax: +82 55 601 5506  
E-Mail: jaeok.kim@keb.de Internet: www.keb.de

**Spain** | KEB Automation KG  
c / Mitjer, Nave 8 - Pol. Ind. LA MASIA  
08798 Sant Cugat Sesgarrigues (Barcelona) Spain  
Tel: +34 93 8970268 Fax: +34 93 8992035 E-Mail: vb.espana@keb.de

**Switzerland** | KEB Automation AG  
Witzbergstrasse 24 8330 Pfaeffikon/ZH Switzerland  
Tel: +41 43 2886060 Fax: +41 43 2886088  
E-Mail: info@keb.ch Internet: www.keb.ch

**United Kingdom** | KEB (UK) Ltd.  
5 Morris Close Park Farm Industrial Estate  
Wellingborough, Northants, NN8 6 XF United Kingdom  
Tel: +44 1933 402220 Fax: +44 1933 400724  
E-Mail: info@keb.co.uk Internet: www.keb.co.uk

**United States** | KEB America, Inc  
5100 Valley Industrial Blvd. South  
Shakopee, MN 55379 United States  
Tel: +1 952 2241400 Fax: +1 952 2241499  
E-Mail: info@kebameric.com Internet: www.kebameric.com



**MORE KEB PARTNERS WORLDWIDE:**

[www.keb-automation.com/contact](http://www.keb-automation.com/contact)



**Automation with Drive**

**[www.keb.de](http://www.keb.de)**

KEB Automation KG Suedstrasse 38 32683 Barntrup Tel. +49 5263 401-0 E-Mail: [info@keb.de](mailto:info@keb.de)